



Line Tracer
MI 2093
T10K, R10K
User Manual

Ver. 3.2.6, Code No. 20 750 717

Distributor:

Manufacturer:

Metrel d.d.
Ljubljanska cesta 77
SI-1354 Horjul
Slovenia
<https://www.metrel.si>
info@metrel.si

DATA BACKUP AND LOSS:

It is the user's responsibility to ensure the integrity and security of the data carrier (SD card) and to regularly backup and validate the integrity of backups of the data. METREL HAS NO OBLIGATION OR LIABILITY FOR ANY LOSS, ALTERATION, DESTRUCTION, DAMAGE, CORRUPTION OR RECOVERY OF USER DATA, REGARDLESS OF WHERE THE DATA IS STORED.



Mark on your equipment certifies that it meets requirements of all subjected EU regulations.



Hereby, Metrel d.d. declares that the MI 2093 is in compliance with subjected EU directive. The full text of the EU declaration of conformity is available at the following internet address <https://www.metrel.si/DoC>.

© 2022 METREL

The trade names Metrel®, Smartec®, Eurotest®, Auto Sequence® are trademarks registered in Europe and other countries.

No part of this publication may be reproduced or utilized in any form or by any means without permission in writing from METREL.

1. Introduction	4
1.1. General Description	4
1.2. Applied Standards.....	4
1.3. Warnings.....	4
1.4. Fields of Use	5
1.5. Transmitter T10K	5
1.6. Receiver R10K.....	6
2. Operation principle	8
2.1. Fundamentals	8
2.2. Tracing the electromagnetic field of lines	10
2.3. Tracing the electrical field of lines	14
3. Typical applications	16
3.0. Detecting energized state of installation.....	16
3.1. Tracing Cables in Walls, Ceilings, Floor and Ground, and Defected Fuses.....	17
3.3. Determining Individual Wires, Fuses etc.	19
4. Tehnical characteristics	21
4.1 Transmitter T10K	21
4.2. Receiver R10K.....	21
5. Meintenance	22
5.1. Battery Replacement for Transmitter T10K.....	22
5.2. Battery Replacement for Receiver R10K.....	22
5.3. Cleaning.....	22
5.4. Service	22
6. Ordering information	23
6.1. Standard Set	23
6.2. Optional accessories	23

1. Introduction

1.1. General Description

The **Line Tracer** is universal equipment intended for tracing hidden conductive paths under plasters in walls, floors, and ground or for determining one wire in a tuft of wires. Fuses or outlets belonging to a certain loop can be located. The **Line Tracer** helps the operator to resolve hidden line problems easily (short-circuit, interruption).

It consists of a transmitting unit (transmitter) T10K, a receiving unit (receiver) R10K and accessories. The transmitter injects emitted signal into the observed installation and this signal is then traced with the receiver. Units are independent of each other.

Accessories, such as a test lead for direct touching of the traced conductor, a voltage output current clamp, and a selective probe, make the **Line Tracer** even more useful.

The instrument is supplied with all the accessories necessary for carrying out the tests. It is stored in a soft carrying bag together with the accessories.

Most of the electronic parts of the instrument are produced in SMD technology; therefore almost no service interventions are needed.

1.2. Applied Standards

Safety: EN / IEC 61010-1 (instrument),
EN / IEC 61010-031 (accessories)
EMC: EN / IEC 61326

1.3. Warnings

In order to reach the highest level of operator's safety while carrying out various tests using the Line Tracer, as well as to ensure the test equipment to remain undamaged, it is necessary to consider the following general warnings:

- If the test equipment is used in a manner not specified in this User Manual, the protection provided by the equipment may be impaired!
- Do not use the instrument and accessories, if any damage is noticed!
- Only a competent and authorized person should carry out any service intervention!
- Consider all generally known precautions in order to avoid risk of electric shock while dealing with electric installations!
- Use only standard or optional test accessories supplied by your distributor for this line tracing system!
- Never make tracing loops from Line to ground or other accessible conductive parts, hazardous live!
-  symbol on the instrument means "Read the User Manual with special care!"

- Disconnect all test leads and switch the power off before opening the Battery cover!
- Never touch metal tip of test probes or put fingers over protection barrier. See the figure below:

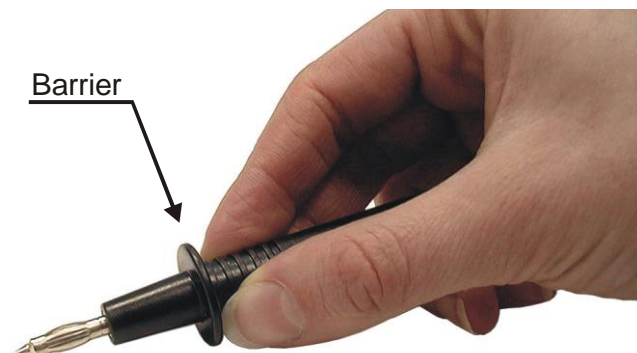

Correct and safety

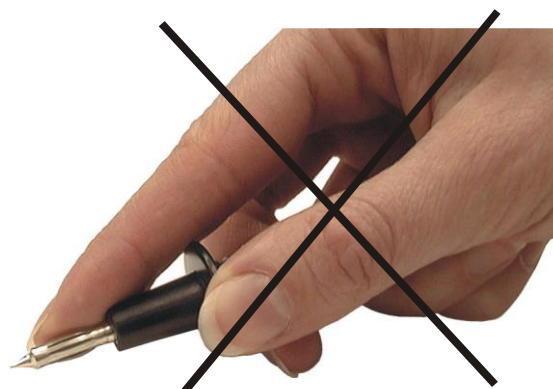

Wrong and **Hazardous live**

- Max tip voltage = 250 V \cong

1.4. Fields of Use

The primary fields of use are electrical installations but the **Line Tracer** can be also a useful tool in telecommunications, computer network installations and elsewhere.

The main activities that can be carried out:

- Tracing cables in walls, ceilings, floor and ground.
- Tracing live or voltage free cables.
- Locating cable interruptions and short-circuits in cables.
- Locating concealed sockets and distribution boxes.
- Locating fuses and assignment to circuits.
- Determining an individual wire in a bundle of wires.
- Detecting the energized state of traced installation.
- Tracing pipe installations and other conductive loops.

Note: when using the **Line Tracer** MI 2093 for the first time, it is recommended to apply it on known object, e.g. a known cable location in the wall, known fuses etc. In this way the user gains the necessary skill for performing the measurements.

1.5. Transmitter T10K

The **transmitter T10K** generates signal, which is connected to a traced object. The state of an external voltage present at the output terminals selects one of the two modes of generating the test signal.

External voltage on terminals	Test signal generating mode
30 V ÷ 264 V, a.c., 50 Hz or 60 Hz	Active load
d.c. or < 30 V a.c.	Internal source

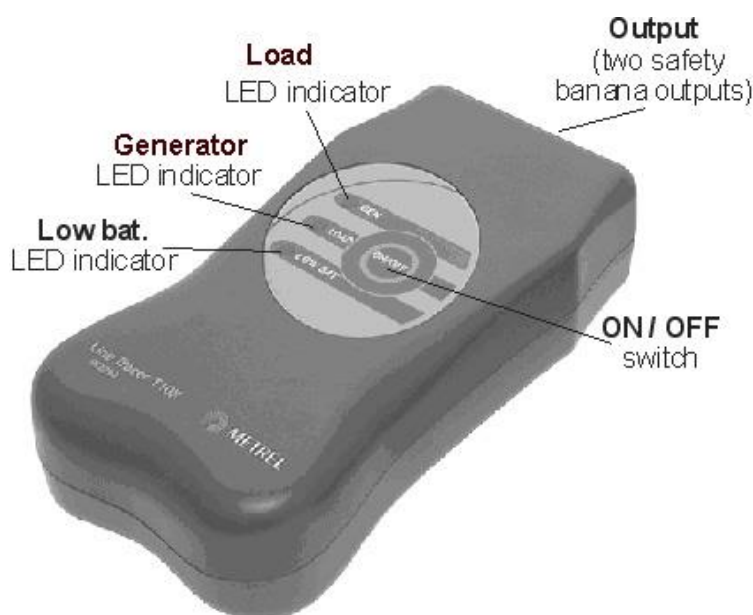

Fig. 1. Transmitter T10K

In both modes 10.6 kHz signal bursts are injected directly into the connected line or coupled via an optional current clamp.

Led indicators on the **transmitter T10K** have the following meaning:

All off	The transmitter is switched off
Low bat	The battery is empty and has to be replaced with a new one, <u>see chapter 5.1.</u>
LOAD	The transmitter generates signal as the active load
GEN	The internal source is activated

The transmitter T10K is supplied by 4 alkaline AA size (IEC LR 6) battery cells.

1.6. Receiver R10K

The highly sensitive hand-held **Receiver R10K** detects the injected signal around the traced line. It generates sound and visual output relative to the signal intensity. Its constructional designed points with its head detector to the maximum of detected signal and the center of traced object. The slide switch of head detector enables the selection between two built-in sensors.

Detector	Sensor selector	Recommendations
Inductive	Slide switch IND	<ul style="list-style-type: none"> - traced object is normally energized - transmitter acts as active load - loading current generates magnetic field around conductor

Capacitive	Slide switch CAP	<ul style="list-style-type: none"> - traced object is normally voltage free - transmitter has its internal source activated - object acts as electrical field radiator
External	Rear connector	<ul style="list-style-type: none"> - for additional accessories like current clamp, electric probe tip and selective sensor - keep maximum distance to traced object in order to avoid interference of received signals through sensor head

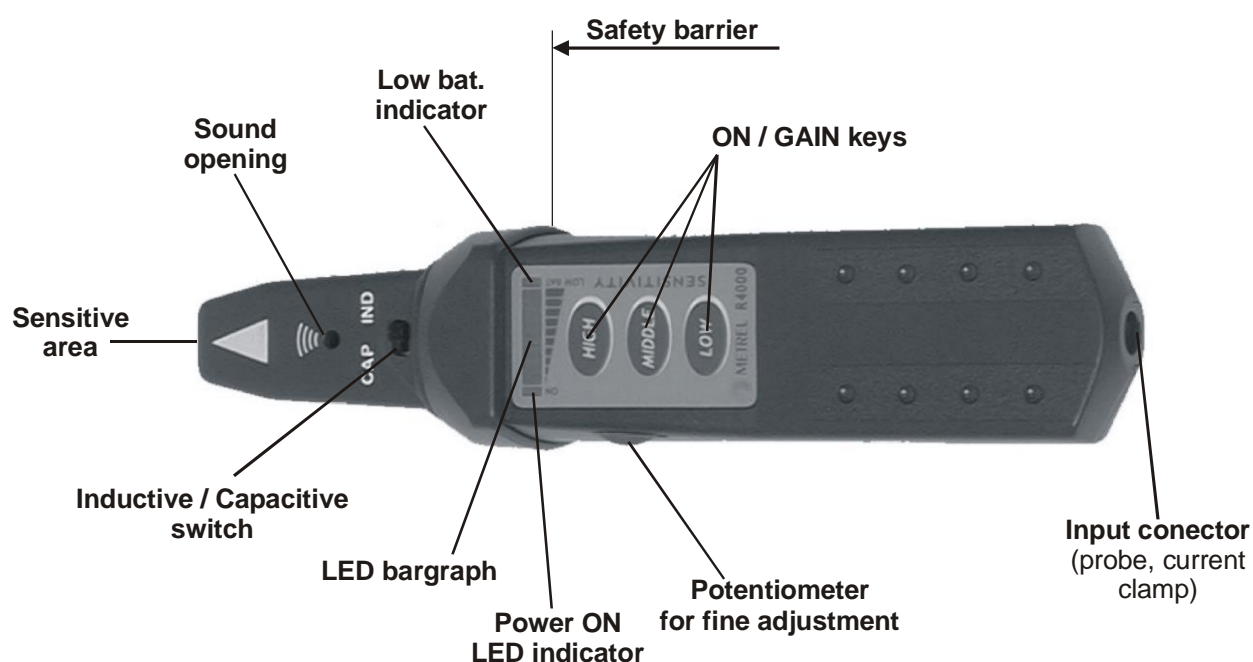

Fig. 2. Receiver R10K

You can choose between three sensitivities (low, middle and high). An extra potentiometer is added for fine sensitivity adjustment. A buzzer sound and 10-level LED bar graph indicator suffice to indicate the location of the traced object.

Notes:

Always select sensitivity that is optimal for individual tracing. The sensitivity can be changed during tracing.

Do not connect input connector to hazardous alive voltage

The receiver R10K is supplied by a 9V alkaline battery (IEC 6LR61).

2. Operation principle

2.1. Fundamentals

Decision for tracing mode selection depends on the object, its structure, energized state and many other reasons. Understanding the electric and magnetic field characteristics leads to selecting the most applicable method. For most of the applications good sensitivity is required, especially when the searched conductor is located far away. Contrary to this the minimum sensitivity is required for selection of a searched conductor in a group of similar conductors. The sensitivity will be in-between for finding appropriate protective device (fuse) or conductors in the proximity.

The basis for all tracing of this kind is that the traced object is electrically conductive.

Current loops and electromagnetic field

Magnetic field is always present around current carrying conductors.

Example	Basic circuit	Description
Free conductor		<ul style="list-style-type: none"> - magnetic field (H) is distributed around conductor - current (I) is limited to internal source capability - INDuctive sensor is applicable for tracing
Metallic loops		<ul style="list-style-type: none"> - current is transformed with a clamp transformer (CT) n times to n·I - always the shortest path (e.g. 1) carry maximum current and is traceable - INDuctive sensor is applicable for tracing
Single wall socket connection		<ul style="list-style-type: none"> - active load source (ALS) generates current - major part of magnetic field (H) is concentrated in a gap between conductors - rest of the field depends on wire distance - INDuctive sensor is applicable for tracing (up to a few cm distance)
Two wall sockets with different conduits to the point of common coupling		<ul style="list-style-type: none"> - active load source (ALS) generates current - magnetic field is distributed around each of current carrying conductors - INDuctive sensor is applicable for tracing

Notes:



Inductive sensor contains a winding. The best sensitivity is always achieved when the winding axis is parallel to the magnetic field around the searched object. Always try to find the best signal by rotating the sensor around its axis.

The traced object with good conductivity has very low voltage drop and weak electrical field in parallel with it.

If a source in active load mode is connected to the energized line with significant internal impedance then voltage variations of loading are also sources of electrical field around line. The detectability of the electrical field is mentioned below.

Electric field

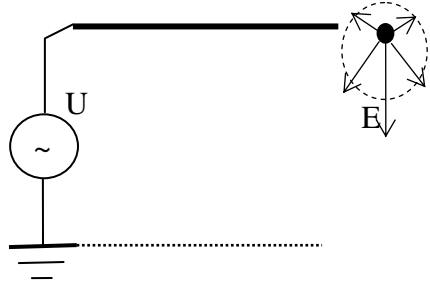
Electric field is always present between two conductors or points of different potential. In most cases the potential is between a conductor and ground or between two neighbor conductors.

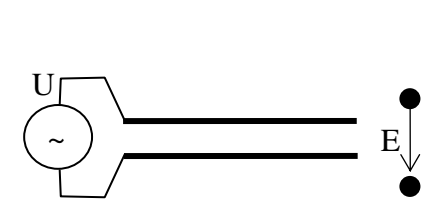
Example	Basic circuit	Description
Free conductor		<ul style="list-style-type: none"> - electrical field is distributed around conductor - maximum magnitude of electric field between conductor and closest conductive ground - CAPacitive sensor is applicable for tracing
Two conductors and wide distance		<ul style="list-style-type: none"> - electrical field is distributed around each conductor - maximum magnitude of electric field between conductors - CAPacitive sensor is applicable for tracing
Two conductors and tiny distance		<ul style="list-style-type: none"> - major part of electric field is concentrated in a gap between conductors - rest of the field depends on distance between conductors - CAPacitive sensor is applicable for tracing (up to a few cm distance)

Note for shielded conductor:

if source (U) is connected between inner conductor and shield no field can be detected.

2.2. Tracing the electromagnetic field of lines

a) Energized lines, the transmitter in LOAD mode

Hints:

When the transmitter is connected to energized lines the loop is determined with the mains transformer.

Tracing this way will give the best results and selectivity because of high values of the injected current.

The tracing principle allows accurate tracing even on longer distances.

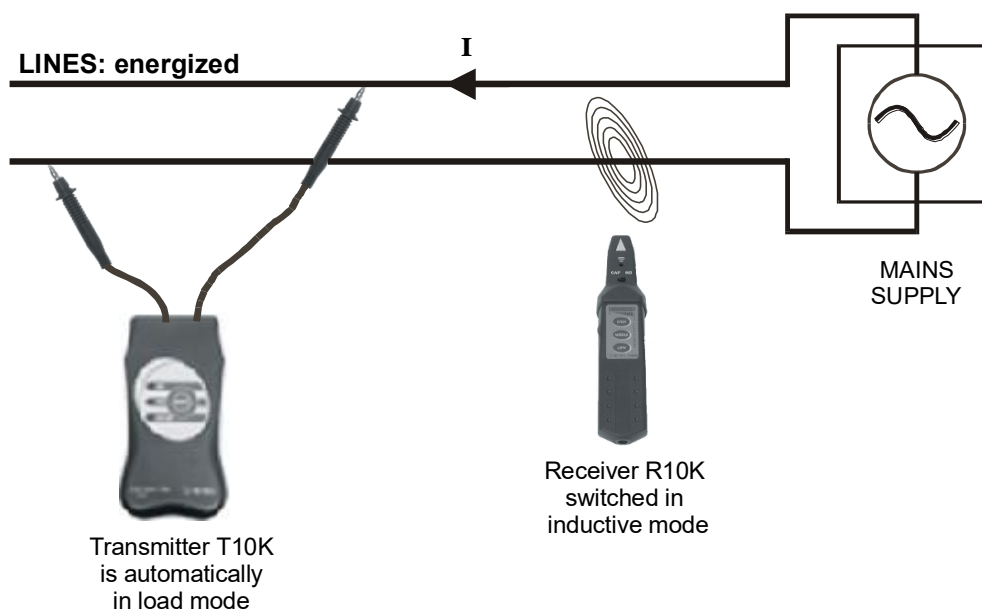

Fig. 3. Transmitter as active load

Detection possibilities for traced object

Tracing object	Distance up to	Notes
Pair of conductors	Up to 40 cm	- one wall socket connection
Wide conductor loop	Up to 2 m	- connection between L in one wall socket and N in the other with separated conduits <i>Note:</i> proper connection is indicated with LED LOAD on transmitter (LED lights when voltage is present)

Hints, continued:

The position of the Receiver must be considered (see the figures below)! Also wire direction can be defined this way.



Fig. 4. Detection of electromagnetic field

Whenever it is possible to embrace the traced wire or pipe it is recommended to use the appropriate current clamp instead of the receiver's inductive sensor (see figure below). By using the clamp, the signal selectivity will considerably improve. Always keep maximum distance between current clamp and R10K.

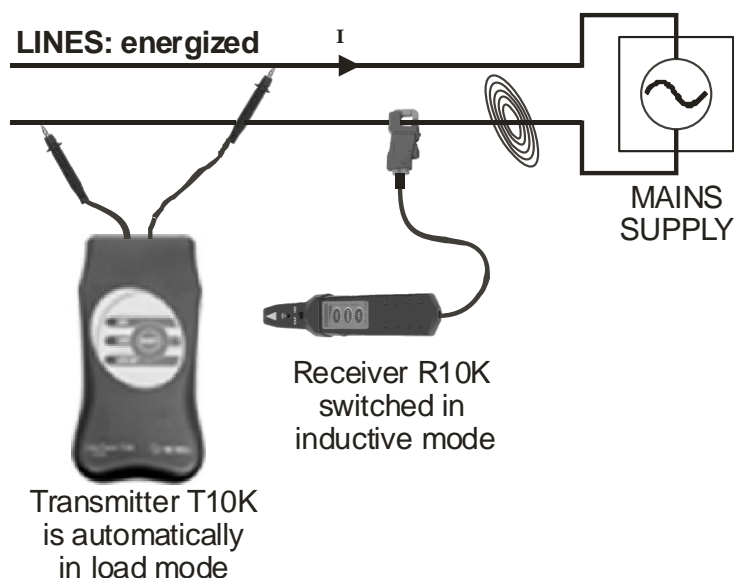

Fig. 5. Transmitter as active load, clamp used instead of inductive sensor

For searching a fuse in a group of them the selective probe should be applied. With it the housing of the fuse or wire must be touched at the right angle. Find the best signal by rotating the probe. Keep maximum distance between R10K and selective probe.

Note: keep fingers behind the probe barrier to avoid electric shock and access of live parts.

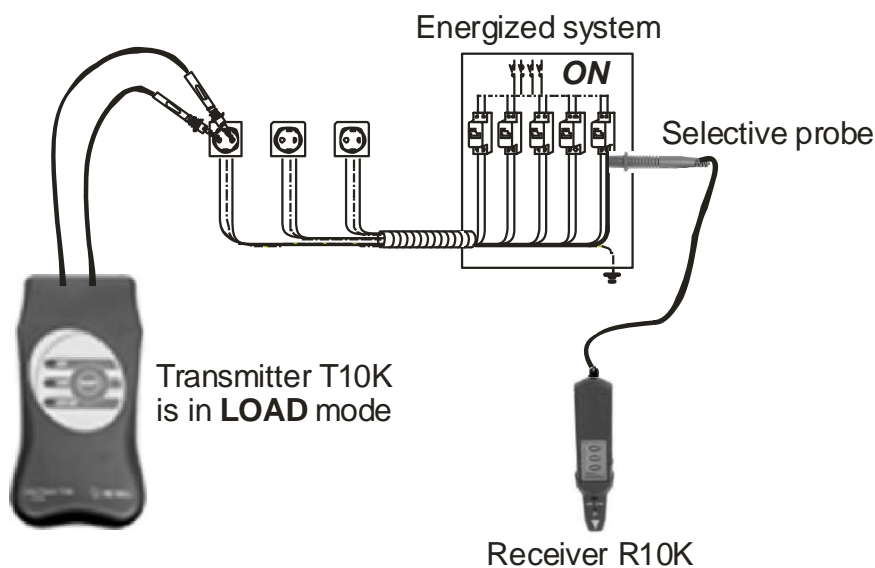

Fig. 6. Searching the fuse

b) Non-energized lines, the transmitter in GEN mode

Hints: continued

When the traced lines are in short circuit, the test current from internal generator of the transmitter unit T10K flows through the tested loop.

This can also happen in case of cable shorts, connected bulbs or other loads etc.

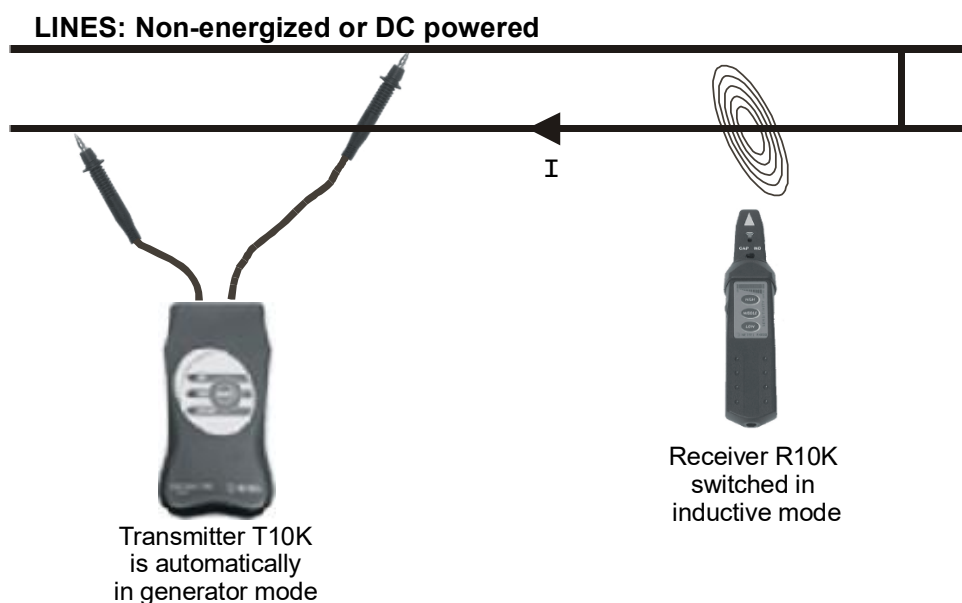

Fig. 7. Injection of test current into tested loop

Detection possibilities for traced object

Tracing object	Distance	Notes
Pair of conductors	Up to 5 cm	

Hints: continued

When tracing conductive loops like pipe installation it is often not possible to disconnect them from each other (taps, radiators etc). In such situations it is possible to inject the test signal into the loop by using a current clamp.

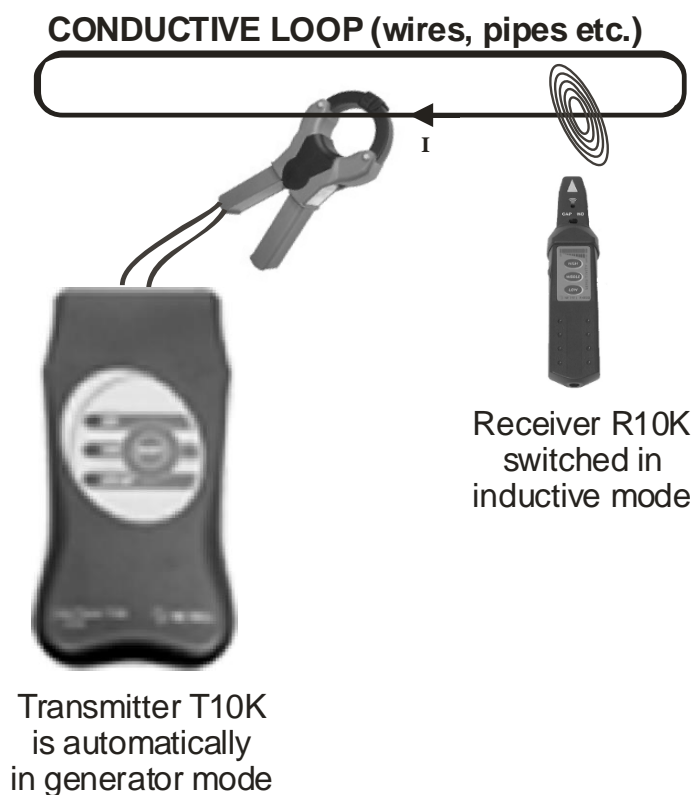

Fig. 8. Injection of test current into closed tested loop by means of current clamp

Detection possibilities for traced object

Tracing object	Distance up to	Notes
Wire, pipe	10 cm	Pay attention to shorts that reduce basic loop size

2.3. Tracing the electrical field of lines

Hints:

The traced line should be insulated from ground to receive a strong and selective signal. Switches and loads must be switched off (switch off the main transformers, grounding capacitors etc.) to prevent attenuation of the injected signal.

If the traced line has ground connection, then the current flows and it is possible to trace in inductive mode of the receiver.

LINES: Non-energized DC powered

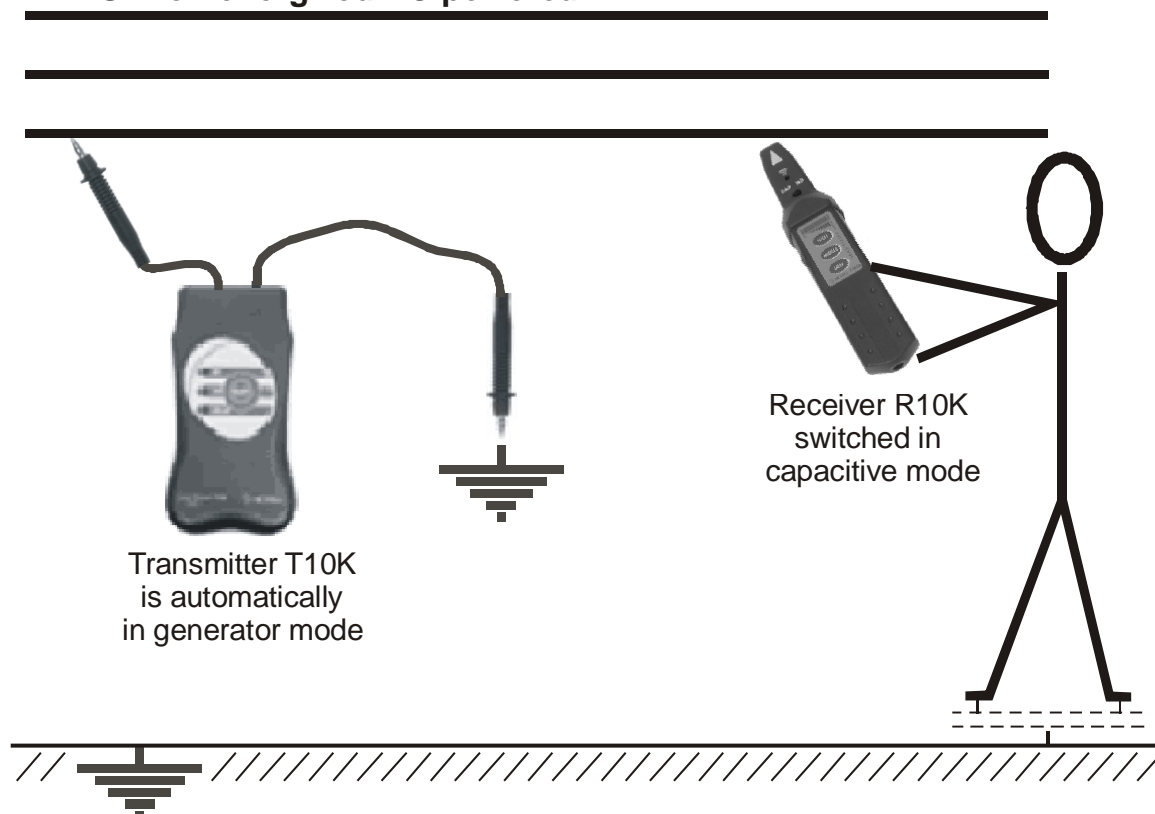

Fig. 9. Tracing the electrical field of a line

Detection possibilities for the traced object

Tracing object	Distance up to	Notes
Conductor	30 cm	

Whenever the traced line or a part of the traced line is accessible it is recommended to use the appropriate Test Tip, connected to the Receiver R10K (see the figure below).

The signal selectivity will be improved by using the test tip.

This allows applications like determining fuses, individual wires in a tuft of wires etc. In that case LOW sensitivity key for lowest signal gain is recommended.

LINES: Non-energized DC powered

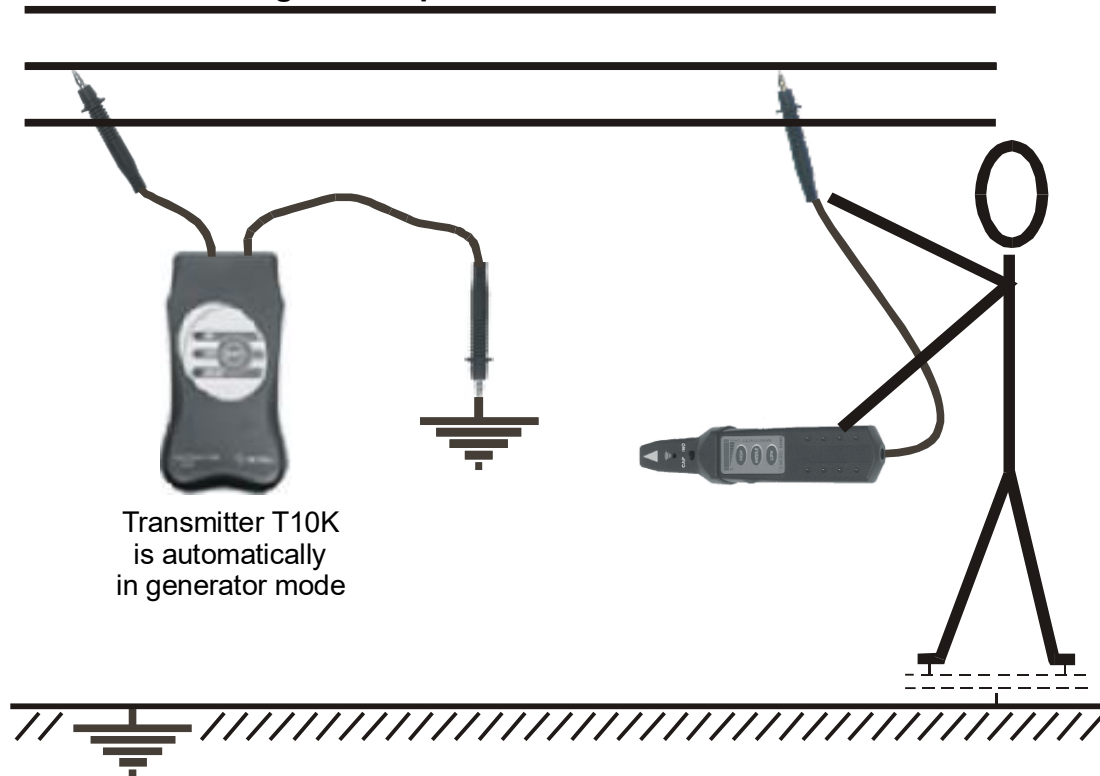

Fig. 10. Tracing the conductor using Test tip

3. Typical applications

3.0. Detecting energized state of installation

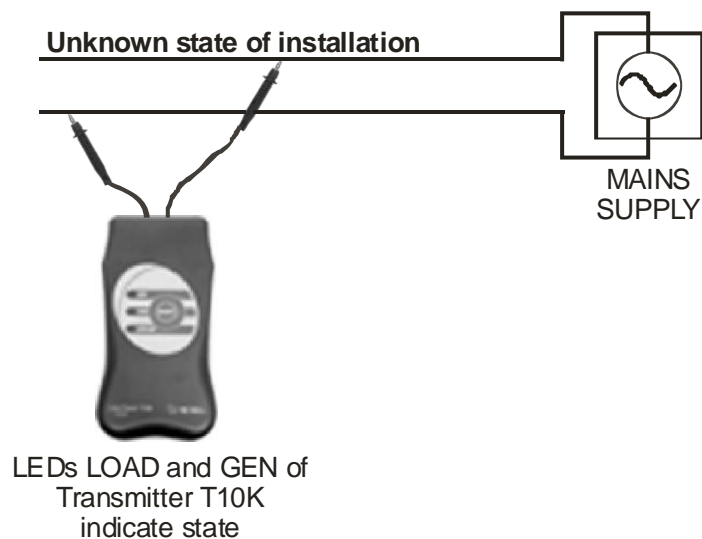

Fig. 11. Transmitter acts as energized state detector

The transmitter T10K automatically recognizes the energized state of the line connected to. As mentioned in paragraph 1.5. the LED indicators, i.e. LOAD and GEN, show internal working condition.

The following table contains the two possible states:

External voltage on terminals	LED activated
30 V ÷ 264 V, a.c., 50 Hz or 60 Hz	LOAD
d.c. or <30 V a.c.	GEN

3.1. Tracing Cables in Walls, Ceilings, Floor and Ground, and Defected Fuses

Tracing of Hidden Wires on Non-energized Systems

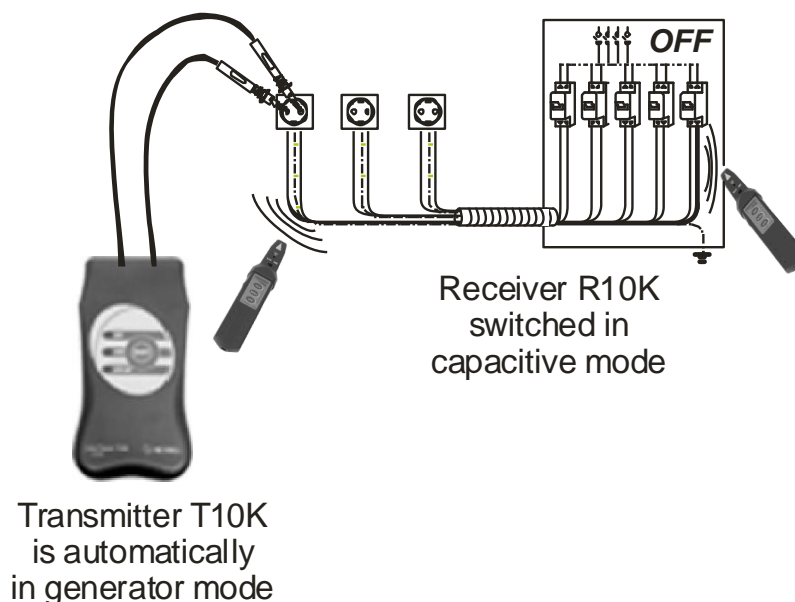

Fig. 12. Tracing cable or determination of the belonging fuse on non-energized installation. The receiver detects the electrical field, caused by the voltage generation of the transmitter.

Tracing Cables in Walls, Ceilings, Floor and Ground on Energized Systems

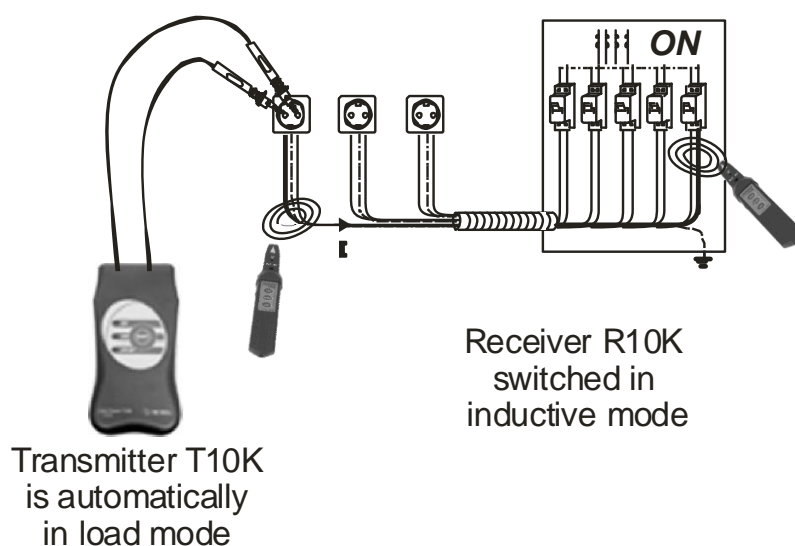

Fig. 13. Tracing cable or determination of the belonging fuse on energized installation. The receiver detects the electromagnetic field caused by load current of the transmitter.

Note: The tracing distance can be increased, if the transmitter is connected to N of one wall socket and L of another wall socket.

3.2. Determining Cable Faults

Locating cable interruptions

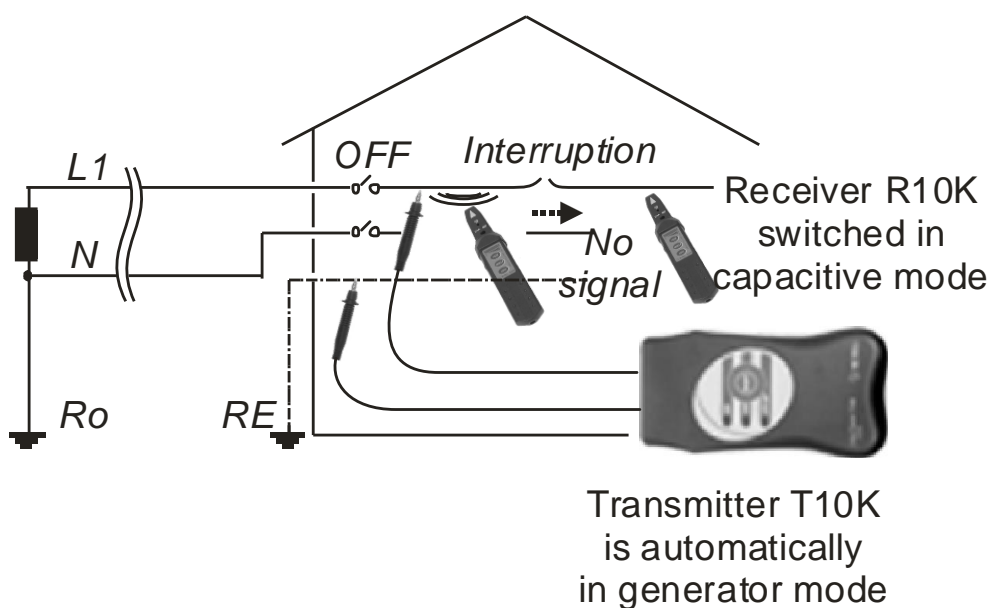

Fig. 14. Determination of interruption location-electrical field caused by transmitter disappears behind the interruption.

Locating earth fault

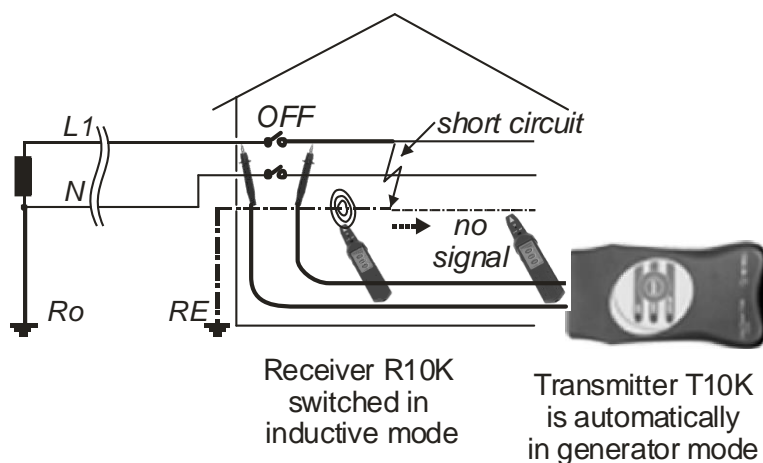

Fig. 15. Determination of short circuit location

Electromagnetic field disappears behind the short circuit location.

Attention: Load current of Transmitter is 1 A. Therefore for the safety reasons the max. value of RE is less than 50Ω .

3.3. Determining Individual Wires, Fuses etc.

Using Special Test Tip

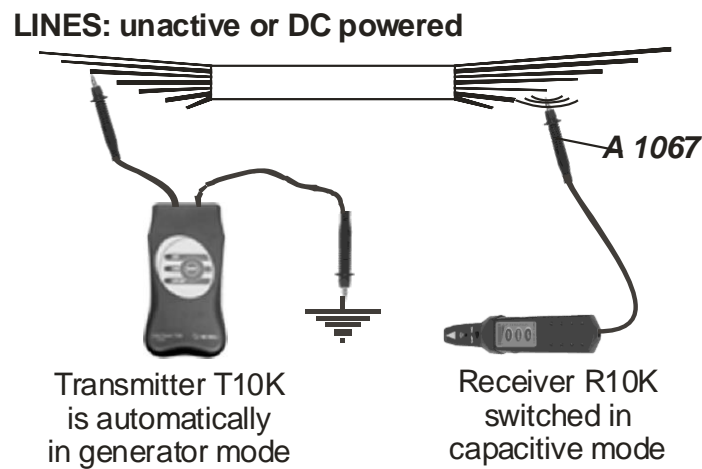

Fig. 16. Determination of individual wire

The Test Tip connected to the receiver is used for determining an individual wire. The lowest gain is recommended for this kind of application (LOW gain)

Using Special Current Clamp

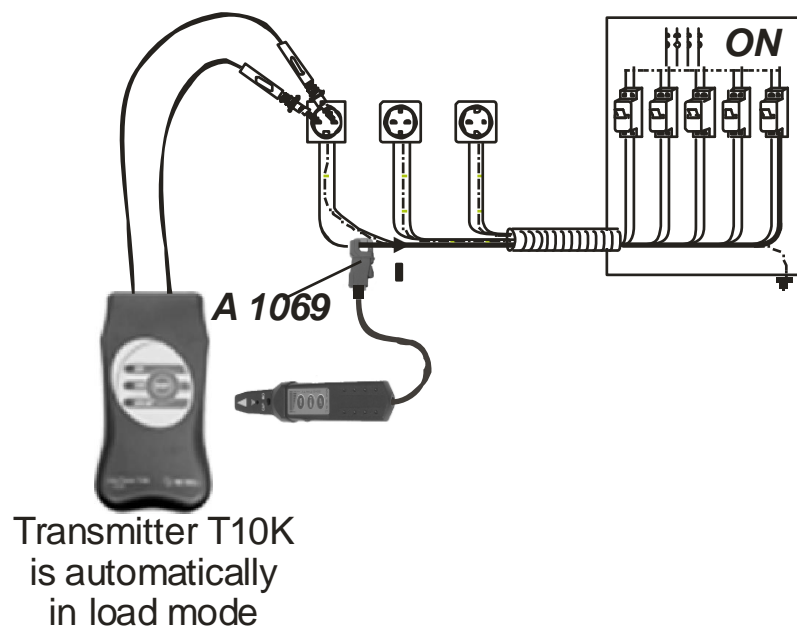

Fig. 17. Determination of the belonging fuse by using current clamp

Current clamp can be used to exactly determine an individual wire or belonging fuse. It is recommended to use the lowest gain for this purpose (LOW gain).

Using Current Clamp for Current-Signal Injection

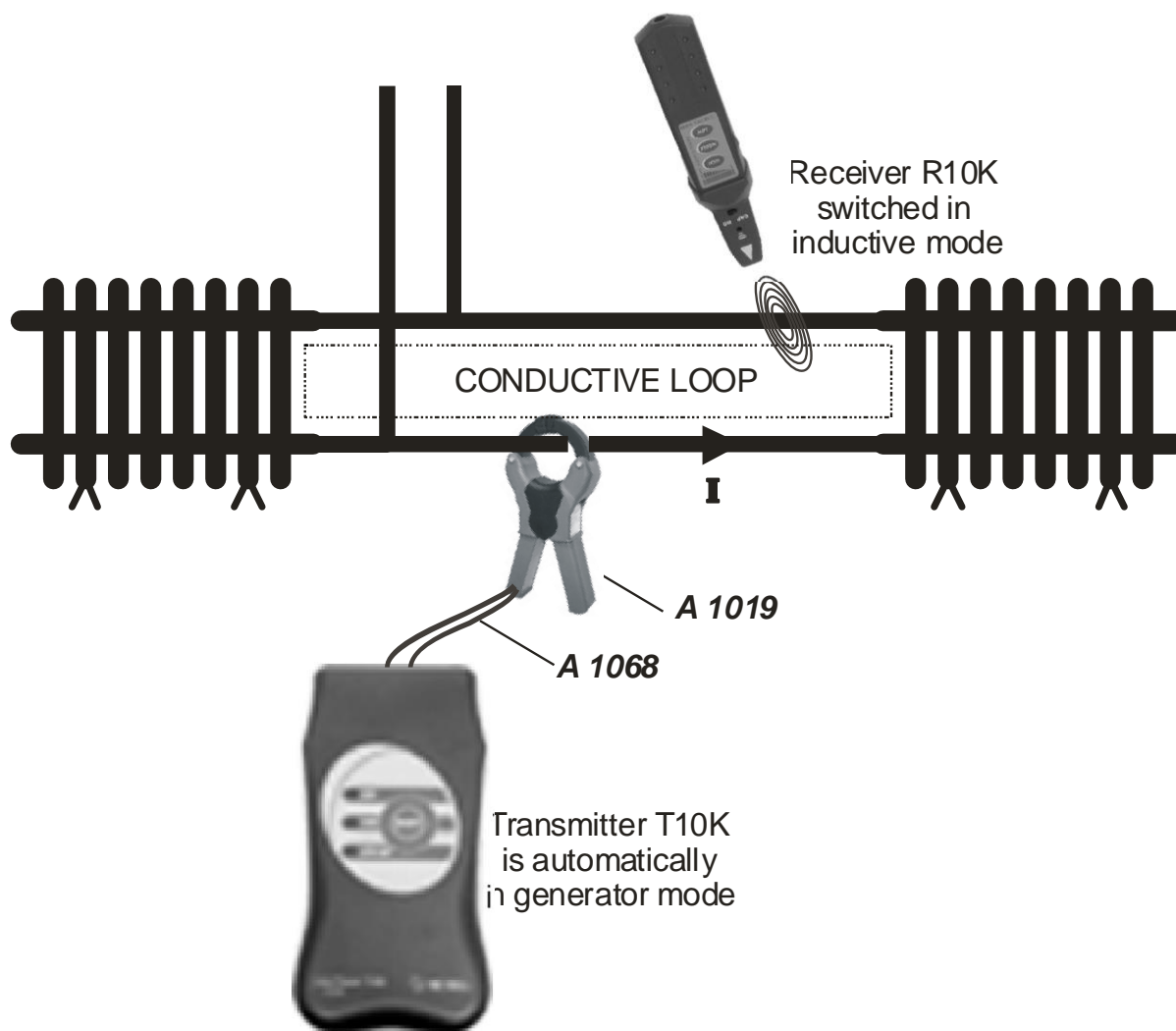

Fig. 18. *Tracing conductive loops by using current clamp*

Instead of a direct current-signal injection, clamp can be used for this purpose and conductive loop can be traced afterwards.

4. Tehnical characteristics

4.1 Transmitter T10K

Batteries:	4 x AA size (1.5 V)
Low battery indicator:	Built in
Operating temperature:	0 °C – +40 °C
Storage temperature:	-30 °C – +60 °C
Weight:	280 g
Housing:	ABS plastics
Dimensions:	80 mm x 50 mm x 150 mm
Overvoltages	CAT III 300 V
Pollution degree	2

Automatic switching between generator and load mode according to input voltage.

Transmitter T10K in Generator Mode

DC, AC voltage:	< 30 V or no voltage present on line
Operating frequency:	10.6 KHz modulated with 4 Hz
Maximum open circuit voltage:	6 V r.m.s.
Maximum short circuit current:	20 mA r.m.s.

Transmitter T10K in Load Mode

System voltage necessary for transmitting:	30 V ÷ 264 V, a.c.
System frequency:	45 Hz ÷ 65 Hz
Operating frequency:	10.6 KHz modulated with 4 Hz
Maximum average injected current:	1 A r.m.s.

4.2. Receiver R10K

Battery:	1 x 6LR61 size (9 V)
Low battery indicator:	Built in
Operating temperature:	0 °C – +40 °C
Storage temperature:	-30 °C – +60 °C
Weight:	140 g
Housing:	ABS plastics
Dimensions:	45 mm x 45 mm x 210 mm

Built-in mechanical switch to select between capacitive and inductive mode.

Sensor:	Built-in capacitive sensor for electric field tracing and inductive sensor for magnetic field tracing
Selectivity:	Input band-pass filter 10.6 KHz
Indicators:	Audio - piezoelectric speaker (70 dB) Visual - 10 level LED bargraph-style indicator
Sensitivity:	LOW, MIDDLE, HIGH sensitivity keys, potentiometer for fine adjustment of signal gain

5. Maintenance

5.1. Battery Replacement for Transmitter T10K



Disconnect all test leads before opening the battery cover.

Unscrew all four screws at the bottom of case.

Remove the cover.

Replace all four battery cells. Pay attention to correct battery polarity.

Fix the cover with all four screws to original position.

The transmitter is energized with four alkaline AA size 1.5 V battery cells.

5.2. Battery Replacement for Receiver R10K

Unscrew two screws on the bottom of casing.

Remove the cover.

Replace the battery. Pay attention to correct battery polarity.

Fix the cover back to the original position.

Receiver is energized with one 9 V battery (IEC 6LR61).

5.3. Cleaning

Use soft patch moistened by water or alcohol, and leave the instrument to dry totally after the cleaning.

Do not use liquids based on petrol!

Do not spill cleaning liquid over the instrument!

5.4. Service

In case of any instrument malfunction or damage, noticed on the instrument or its accessories, a competent service department must service the instrument. Contact your dealer for detailed information.

6. Ordering information

6.1. Standard Set

Order no.: **MI 2093**

Transmitter T10K

Receiver R10K

Two test leads (safety banana on both sides), black, 1.5 m, (for T10K)

Special selective tip probe

Test tip, 2pcs

Alligator clip, 2pcs

Small soft carrying bag

6.2. Optional accessories

Current clamp 1000 A / 1 A, d = 52 mm **A 1019**

Test lead, 1.5 m, with built in resistor, (for R10K) **A 1067**

Connection cable for clamp **A 1068**

Current clamp 200 A / 0.2 A, d = 15 mm **A 1074**

