



**Energy Master XA/Energy Master
MI 2884/MI 2883
(HW4.0)**

Instruction manual

Version 1.7.10, Code No. 20 753 130

Distributor:

Manufacturer:

Metrel d.o.o.
Ljubljanska cesta 77
SI-1354 Horjul
Slovenia
<https://www.metrel.si>
info@metrel.si



Mark on your equipment certifies that it meets requirements of all subjected EU regulations.



Hereby, Metrel d.o.o. declares that the MI 2884, MI 2883 is in compliance with subjected EU directive. The full text of the EU declaration of conformity is available at the following internet address <http://www.metrel.si/DoC>.

© 2023 METREL

The trade names Metrel®, Smartec®, Eurotest®, Auto Sequence® are trademarks registered in Europe and other countries.

No part of this publication may be reproduced or utilized in any form or by any means without permission in writing from METREL.

1	Introduction.....	14
2	Main Features	15
2.1	Safety considerations	16
2.2	Applicable standards	17
2.3	Abbreviations.....	18
3	Description.....	29
3.1	Front panel	29
3.2	Connector panel	30
3.3	Bottom view	31
3.4	Accessories	31
3.4.1	Standard accessories.....	31
3.4.2	Optional accessories	31
4	Operating the instrument.....	32
4.1	Instrument status bar.....	33
4.2	Instrument keys	34
4.3	Instrument memory (microSD card)	34
4.4	Instrument Main Menu.....	35
4.4.1	Instrument submenus.....	36
4.5	U, I, f.....	38
4.5.1	Meter.....	38
4.5.2	Scope	40
4.5.3	Trend.....	42
4.6	Power	44
4.6.1	Meter	44
4.6.2	Trend.....	46
4.7	Energy	50
4.7.1	Meter.....	50
4.7.2	Trend.....	51
4.7.3	Efficiency.....	52
4.8	Harmonics / interharmonics.....	55
4.8.1	Meter	55
4.8.2	Histogram (Bar)	57
4.8.3	Harmonics Average Histogram (Avg Bar)	59
4.8.4	Trend.....	60
4.9	Flickers	62
4.9.1	Meter.....	62
4.9.2	Trend.....	63
4.10	Phase Diagram.....	65
4.10.1	Phase diagram	65
4.10.2	Unbalance diagram	66
4.10.3	Unbalance trend	68
4.11	Temperature.....	69
4.11.1	Meter.....	69
4.11.2	Trend.....	70
4.12	Underdeviation and overdeviation	70
4.12.1	Meter.....	70
4.12.2	Trend.....	71
4.13	Signalling.....	73
4.13.1	Meter.....	73
4.13.2	Trend.....	74

4.13.3	Table	75
4.14	General Recorder	76
4.15	Waveform/inrush recorder (available at Energy Master XA).....	80
4.15.1	Setup	80
4.15.2	Capturing waveform	82
4.15.3	Captured waveform	84
4.16	Transient recorder (available at Energy Master XA).....	85
4.16.1	Setup	85
4.16.2	Capturing transients	87
4.16.3	Captured transients	88
4.17	Events table.....	90
4.18	Alarms table	94
4.19	Rapid voltage changes (RVC) table	96
4.20	Memory List.....	97
4.20.1	General Record	98
4.20.2	Waveform snapshot	101
4.20.3	Waveform/inrush record (available at Energy Master XA).....	103
4.20.4	Transients record (available at Energy Master XA).....	103
4.21	Measurement Setup submenu	103
4.21.1	Connection setup	104
4.21.2	Event setup	110
4.21.3	Alarm setup	112
4.21.4	Signalling setup	113
4.21.5	Rapid voltage changes (RVC) setup	114
4.21.6	Measuring Methods setup	115
4.22	General Setup submenu.....	116
4.22.1	Time & Date	116
4.22.2	Language	117
4.22.3	Instrument info	118
4.22.4	Lock/Unlock.....	118
4.22.5	Colour model.....	120
4.22.6	Backlight.....	121
5	Recording Practice and Instrument Connection	123
5.1	Measurement campaign	123
5.2	Connection setup	127
5.2.1	Connection to the LV Power Systems	127
5.2.2	Connection to the MV or HV Power System.....	132
5.2.3	Current clamp selection and transformation ratio setting	133
5.2.4	Connection check.....	137
5.2.5	Temperature probe connection	140
5.3	Instrument connection to powerView v3.0	141
5.4	Number of measured parameters and connection type relationship	149
6	Theory and internal operation	153
6.1	Measurement methods.....	153
6.1.1	Measurement aggregation over time intervals	153
6.1.2	Voltage measurement (magnitude of supply voltage)	153
6.1.3	Current measurement (magnitude of supply current)	154
6.1.4	Frequency measurement	154
6.1.5	Modern Power measurement.....	155
6.1.6	Classic Vector and Arithmetic Power measurement	160

6.1.7	Energy.....	163
6.1.8	Harmonics and interharmonics.....	165
6.1.9	Signalling.....	167
6.1.10	Flicker.....	167
6.1.11	Voltage and current unbalance	168
6.1.12	Underdeviation and overdeviation	168
6.1.13	Voltage events	169
6.1.14	Alarms	173
6.1.15	Rapid voltage changes (RVC).....	174
6.1.16	Data aggregation in GENERAL RECORDING	175
6.1.17	Flagged data	179
6.1.18	Waveform snapshot	180
6.1.19	Waveform recorder (available at Energy Master XA)	181
6.1.20	Transient recorder.....	184
6.2	EN 50160 Standard Overview	186
6.2.1	Power frequency	186
6.2.2	Supply voltage variations	186
6.2.3	Supply voltage unbalance	186
6.2.4	THD voltage and harmonics.....	187
6.2.5	Interharmonic voltage.....	187
6.2.6	Mains signalling on the supply voltage	187
6.2.7	Flicker severity	188
6.2.8	Voltage dips	188
6.2.9	Voltage swells	189
6.2.10	Short interruptions of the supply voltage	189
6.2.11	Long interruptions of the supply voltage.....	189
6.2.12	Recorder setting for EN 50160 survey	189
7	Technical specifications	190
7.1	General specifications	190
7.2	Measurements.....	190
7.2.1	General description	190
7.2.2	Phase Voltages	191
7.2.3	Line voltages	192
7.2.4	Current	192
7.2.5	Frequency	196
7.2.6	Flickers.....	196
7.2.7	Combined power	196
7.2.8	Fundamental power.....	197
7.2.9	Nonfundamental power	197
7.2.10	Power factor (PF)	198
7.2.11	Displacement factor (DPF) or Cos ϕ	198
7.2.12	Energy.....	199
7.2.13	Voltage harmonics and THD	199
7.2.14	Current harmonics, THD and k-factor.....	199
7.2.15	Voltage interharmonics.....	200
7.2.16	Current interharmonics.....	200
7.2.17	Signalling.....	200
7.2.18	Unbalance	200
7.2.19	Overdeviation and Underdeviation	200
7.2.20	Time and duration uncertainty.....	200
7.2.21	Temperature probe.....	201

7.2.22	Phase angle	201
7.3	Recorders.....	201
7.3.1	General recorder	201
7.3.2	Waveform snapshot	203
7.4	Standards compliance.....	204
7.4.1	Compliance to the IEC 61557-12	204
7.4.2	Compliance to the to the IEC 61000-4-30	205
8	Maintenance.....	206
8.1	Inserting batteries into the instrument	206
8.2	Batteries	207
8.3	Firmware upgrade	208
8.3.1	Requirements.....	208
8.3.2	Upgrade proceduce	209
8.4	Power supply considerations.....	212
8.5	Cleaning	212
8.6	Periodic calibration	213
8.7	Service	213
8.8	Troubleshooting.....	213
9	Version of document.....	213

List of tables:

Table 3.1: Energy Master XA/Energy Master standard accessories.....	31
Table 4.1: Instrument status bar description.....	33
Table 4.2: Shortcut Keys and other Function keys	34
Table 4.3: Instrument Main menu	36
Table 4.4: Keys in Main menu	36
Table 4.5: Keys in submenus	38
Table 4.6: Instrument screen symbols and abbreviations.....	39
Table 4.7: Keys in Meter screens	39
Table 4.8: Instrument screen symbols and abbreviations.....	41
Table 4.9: Keys in Scope screens	41
Table 4.10: Instrument screen symbols and abbreviations.....	43
Table 4.11: Keys in Trend screens	43
Table 4.12: Instrument screen symbols and abbreviations (see 6.1.5 for details)	44
Table 4.13: Keys in Power (METER) screens	46
Table 4.14: Instrument screen symbols and abbreviations.....	47
Table 4.15: Keys in Power (TREND) screens.....	48
Table 4.16: Instrument screen symbols and abbreviations.....	50
Table 4.17: Keys in Energy (METER) screens	51
Table 4.18: Instrument screen symbols and abbreviations.....	51
Table 4.19: Keys in Energy (TREND) screens	52
Table 4.20: Instrument screen symbols and abbreviations.....	52
Table 4.21: Keys in Energy (TREND) screens	54
Table 4.22: Instrument screen symbols and abbreviations.....	56
Table 4.23: Keys in Harmonics / interharmonics (METER) screens	56
Table 4.24: Instrument screen symbols and abbreviations.....	57
Table 4.25: Keys in Harmonics / interharmonics (BAR) screens	58
Table 4.26: Instrument screen symbols and abbreviations.....	59
Table 4.27: Keys in Harmonics / interharmonics (AVG) screens	59
Table 4.28: Instrument screen symbols and abbreviations.....	61
Table 4.29: Keys in Harmonics / interharmonics (TREND) screens	61
Table 4.30: Instrument screen symbols and abbreviations.....	63
Table 4.31: Keys in Flickers (METER) screen	63
Table 4.32: Instrument screen symbols and abbreviations.....	64
Table 4.33: Keys in Flickers (TREND) screens	65
Table 4.34: Instrument screen symbols and abbreviations.....	66
Table 4.35: Keys in Phase diagram screen	66
Table 4.36: Instrument screen symbols and abbreviations.....	67
Table 4.37: Keys in Unbalance diagram screens	67
Table 4.38: Instrument screen symbols and abbreviations.....	68
Table 4.39: Keys in Unbalance trend screens	68
Table 4.40: Instrument screen symbols and abbreviations.....	69
Table 4.41: Keys in Temperature meter screen.....	69
Table 4.42: Instrument screen symbols and abbreviations.....	70
Table 4.43: Keys in Temperature trend screens.....	70
Table 4.44: Instrument screen symbols and abbreviations.....	71
Table 4.45: Keys in Underdeviation and overdeviation (METER) screen	71
Table 4.46: Instrument screen symbols and abbreviations.....	72
Table 4.47: Keys in Underdeviation and Overdeviation (TREND) screens.....	72

Table 4.48: Instrument screen symbols and abbreviations.....	73
Table 4.49: Keys in Signalling (METER) screen.....	73
Table 4.50: Instrument screen symbols and abbreviations.....	74
Table 4.51: Keys in Signalling (TREND) screen.....	74
Table 4.52: Instrument screen symbols and abbreviations.....	75
Table 4.53: Keys in Signalling (TABLE) screen.....	76
Table 4.54: General recorder settings description and screen symbols.....	76
Table 4.55: Keys in General recorder setup screen.....	78
Table 4.56: Waveform recorder settings description and screen symbols.....	80
Table 4.57: Keys in Waveform recorder setup screen.....	81
Table 4.58: Instrument screen symbols and abbreviations.....	83
Table 4.59: Keys in Waveform recorder capture screen.....	83
Table 4.60: Instrument screen symbols and abbreviations.....	84
Table 4.61: Keys in captured waveform recorder screens.....	84
Table 4.62: Transient recorder settings description and screen symbols.....	85
Table 4.63: Keys in Transient recorder setup screen.....	86
Table 4.64: Instrument screen symbols and abbreviations.....	87
Table 4.65: Keys in Transient recorder capture screen.....	87
Table 4.66: Instrument screen symbols and abbreviations.....	88
Table 4.67: Keys in captured transient recorder screens.....	88
Table 4.68: Instrument screen symbols and abbreviations.....	90
Table 4.69: Keys in Events table group view screens.....	91
Table 4.70: Instrument screen symbols and abbreviations.....	92
Table 4.71: Keys in Events table phase view screens.....	93
Table 4.72: Instrument screen symbols and abbreviations.....	94
Table 4.73: Keys in Alarms table screens.....	95
Table 4.74: Instrument screen symbols and abbreviations.....	96
Table 4.75: Keys in RVC Events table group view screens.....	97
Table 4.76: Instrument screen symbols and abbreviations.....	97
Table 4.77: Keys in Memory list screen.....	98
Table 4.78: Recorder settings description.....	99
Table 4.79: Keys in General record front page screen.....	99
Table 4.80: Instrument screen symbols and abbreviations.....	100
Table 4.81: Keys in Viewing recorder U,I,f TREND screens.....	101
Table 4.82: Recorder settings description.....	102
Table 4.83: Keys in Snapshot record front page screen.....	102
Table 4.84: Description of Measurement setup options.....	104
Table 4.85: Keys in Measurement setup submenu screen.....	104
Table 4.86: Description of Connection setup.....	105
Table 4.87: Keys in Connection setup menu.....	109
Table 4.88: Description of Event setup.....	110
Table 4.89: Keys in Event setup screen.....	110
Table 4.90: Description of Alarm setup.....	112
Table 4.91: Keys in Alarm setup screens.....	113
Table 4.92: Description of Signalling setup.....	113
Table 4.93: Keys in Signalling setup screen.....	114
Table 4.94: Description of RVC setup.....	114
Table 4.95: Keys in RVC setup screen.....	115
Table 4.96: Description of Measuring Methods setup.....	115
Table 4.97: Keys in Measuring Methods setup screen.....	115
Table 4.98: Description of General setup options.....	116

Table 4.99: Keys in General setup submenu	116
Table 4.100: Description of Set date/time screen	117
Table 4.101: Keys in Set date/time screen	117
Table 4.102: Keys in Language setup screen.....	118
Table 4.103: Keys in Instrument info screen.....	118
Table 4.104: Description of Lock/Unlock screen.....	119
Table 4.105: Keys in Lock/Unlock screen.....	119
Table 4.106: Locked instrument functionality.....	119
Table 4.107: Keys in Colour model screens	120
Table 4.108: Description Backlight screen.....	122
Table 4.109: Keys in Backlight screen.....	122
Table 5.1: Keys in Smart clamps pop up window	137
Table 5.2: Connection check description and screen symbols	138
Table 5.3: Keys in Connection check screen	140
Table 5.4: Quantities measured by instrument	149
Table 5.5: Quantities recorded by instrument (Standard profile)	150
Table 6.1: Summary and grouping of the phase power quantities	155
Table 6.2: Power summary and grouping of the total power quantities	156
Table 6.3: Summary and grouping of the phase power quantities	161
Table 6.4: Power summary and grouping of the total power quantities	161
Table 6.5: Alarm definition parameters	173
Table 6.6: Alarm signatures.....	174
Table 6.7: Data aggregation methods.....	176
Table 6.8: EN 50160 standard LV limits (continuous phenomena)	186
Table 6.9: Values of individual harmonic voltages at the supply.....	187
Table 6.10: Voltage dips classification.....	188
Table 6.11: Voltage swell classification	189
Table 7.1: General recording max. duration	202

List of Figures:

Figure 1.1: Energy Master XA instrument.....	14
Figure 1.2: Front plates and marking labels.....	15
Figure 3.1: Front panel	29
Figure 3.2: Top connector panel.....	30
Figure 3.3: Side connector panel.....	30
Figure 3.4: Bottom view	31
Figure 4.1: Display symbols and keys description	32
Figure 4.2: Common display symbols and labels during measurement campaign	32
Figure 4.3: Instrument status bar.....	33
Figure 4.4: Inserting microSD card	35
Figure 4.5: "MAIN MENU"	35
Figure 4.6: Measurements submenu	36
Figure 4.7: Recorders submenu – MI 2884	37
Figure 4.8: Recorders submenu – MI 2883	37
Figure 4.9: Measurement setup submenu	37
Figure 4.10: General setup submenu	37
Figure 4.11: U, I, f meter phase table screens (L1, L2, L3, N)	38
Figure 4.12: U, I, f meter summary table screens.....	39
Figure 4.13: Voltage only waveform	40
Figure 4.14: Current only waveform.....	40
Figure 4.15: Voltage and current waveform (single mode)	40
Figure 4.16: Voltage and current waveform (dual mode).....	40
Figure 4.17: Voltage trend (all voltages)	42
Figure 4.18: Voltage trend (single voltage)	42
Figure 4.19: Voltage and current trend (single mode).....	42
Figure 4.20: Voltage and current trend (dual mode)	42
Figure 4.21: Trends of all currents	42
Figure 4.22: Frequency trend	42
Figure 4.23: Power measurements summary (combined)	44
Figure 4.24: Power measurements summary (fundamental)	44
Figure 4.25: Detailed power measurements at phase L1	44
Figure 4.26: Detailed total power measurements	44
Figure 4.27: Power trend screen.....	47
Figure 4.28: Energy counters screen (General Recorder is running)	50
Figure 4.29: Energy counters screen (General Recorder is not running).....	50
Figure 4.30: Energy trend screen	51
Figure 4.31: Energy efficiency screen.....	52
Figure 4.32: Harmonics and interharmonics (METER) screens.....	55
Figure 4.33: Harmonics and Power harmonics (METER) screens.....	55
Figure 4.34: Harmonics histogram screen	57
Figure 4.35: Harmonics average histogram screen	59
Figure 4.36: Harmonics and interharmonics trend screen	61
Figure 4.37: Flickers table screen.....	63
Figure 4.38: Flickers trend screen	64
Figure 4.39: Phase diagram screen.....	66
Figure 4.40: Unbalance diagram screen.....	67
Figure 4.41: Symmetry trend screen.....	68
Figure 4.42: Temperature meter screen	69

Figure 4.43: Temperature trend screen	70
Figure 4.44: Underdeviation and overdeviation table screen	71
Figure 4.45: Underdeviation and overdeviation TREND screen	72
Figure 4.46: Signalling meter screen	73
Figure 4.47: Signalling trend screen	74
Figure 4.48: Signalling table screen.....	75
Figure 4.49: General recorder setup screen	76
Figure 4.50: Triggering in waveform record	80
Figure 4.51: Waveform recorder setup screen	80
Figure 4.52: Waveform recorder capture screen	83
Figure 4.53: Captured waveform recorder screen	84
Figure 4.54: Transient recorder setup screen.....	85
Figure 4.55: Transient recorder capture screen.....	87
Figure 4.56: Captured transient recorder screen	88
Figure 4.57: Voltage events in group view screen	90
Figure 4.58: Voltage event in detail view screen	90
Figure 4.59: Voltage events screens	92
Figure 4.60: Alarms list screen	94
Figure 4.61: RVC Events table group view screen	96
Figure 4.62: Memory list screen	97
Figure 4.63: Front page of General record in MEMORY LIST menu	99
Figure 4.64: Viewing recorder U,I,f TREND data	100
Figure 4.65: Front page of Snapshot in MEMORY LIST menu	102
Figure 4.66: U,I,f meter screen in recalled snapshot record	103
Figure 4.67: MEASUREMENT SETUP submenu	104
Figure 4.68: "CONNECTION SETUP" screen	105
Figure 4.69: Event setup screen.....	110
Figure 4.70: Alarm setup screens	112
Figure 4.71: Signalling setup screen.....	113
Figure 4.72: RVC setup screen	114
Figure 4.73: Measuring Methods setup screen.....	115
Figure 4.74: GENERAL SETUP submenu.....	116
Figure 4.75: Set date/time screen.....	117
Figure 4.76: Language setup screen	118
Figure 4.77: Instrument info screen	118
Figure 4.78: Lock/Unlock screen	119
Figure 4.79: Locked instrument screen.....	120
Figure 4.80: Colour representation of phase voltages	120
Figure 4.81: Backlight screen options.....	122
Figure 5.1: Recommended measurement practice	124
Figure 5.2: Connection setup menu.....	127
Figure 5.3: Choosing 3-phase 4-wire system on instrument.....	128
Figure 5.4: 3-phase 4-wire system.....	128
Figure 5.5: Choosing 3-phase 3-wire system on instrument.....	129
Figure 5.6: 3-phase 3-wire system.....	129
Figure 5.7: Choosing Open Delta (Aaron) 3-wire system on instrument.....	129
Figure 5.8: Open Delta (Aaron) 3-wire system	130
Figure 5.9: Choosing 1-phase 3-wire system on instrument.....	130
Figure 5.10: 1-phase 3-wire system.....	131
Figure 5.11: Choosing 2-phase 4-wire system on instrument.....	131
Figure 5.12: 2-phase 4-wire system.....	132

Figure 5.13: Voltage ratio for 10 kV / 100 V transformer example	132
Figure 5.14: Connecting instrument to the existing current transformers in medium voltage system.....	133
Figure 5.15: Smart current clamps auto range selection	134
Figure 5.16: Parallel feeding of large load	134
Figure 5.17: Current clamps selection for indirect current measurement.....	135
Figure 5.18: Selecting 10% of current clamps range	136
Figure 5.19: Automatically recognised clamps setup.....	136
Figure 5.20: Automatically recognised clamps status	137
Figure 5.21: USB communication settings in PowerView	141
Figure 5.22: Detection of the instrument type	143
Figure 5.23: Downloading a list of records.....	143
Figure 5.24: Selecting records from a list for download.....	144
Figure 5.25: Real time scope window in remote connection, with several channels selected	145
Figure 5.26: Remote Instrument Configuration form.....	146
Figure 5.27: Remote Recorder configuration.....	147
Figure 5.28: Recording in progress.....	148
Figure 6.1: Phase and Phase-to-phase (line) voltage.....	153
Figure 6.2: IEEE 1459 phase power measurement organisation (phase).....	155
Figure 6.3: IEEE 1459 phase power measurement organisation (totals).....	156
Figure 6.4: Vector representation of total power calculus	161
Figure 6.5: Arithmetic representation of total power calculus	161
Figure 6.6: Energy counters and quadrant relationship	164
Figure 6.7: Instrument energy counters	164
Figure 6.8: Current and voltage harmonics.....	165
Figure 6.9: Illustration of harmonics / interharmonics subgroup for 50 Hz supply.....	166
Figure 6.10: Voltage fluctuation	167
Figure 6.11: $U_{Rms(1/2)}$ 1-cycle measurement	170
Figure 6.12 Voltage events definition.....	170
Figure 6.13: Voltage dip related screens on the instrument.....	171
Figure 6.14: Voltage interrupts related screens on the instrument	173
Figure 6.15: RVC event description	175
Figure 6.16: Synchronization and aggregation of 10/12 cycle intervals	176
Figure 6.17: Avg vs. Avgon, switching load current	178
Figure 6.18: Consumed/generated and inductive/capacitive phase/polarity diagram ..	179
Figure 6.19: Flagging data indicate that aggregated value might be unreliable	180
Figure 6.20: Triggering and pre-triggering description	181
Figure 6.21: Voltage Event Triggering	182
Figure 6.22: Voltage Level Triggering.....	182
Figure 6.23: Current Level Triggering (Inrush).....	183
Figure 6.24: Waveform recorder setup for triggering on voltage events	183
Figure 6.25: Level triggering	184
Figure 6.26: Triggering slope.....	184
Figure 6.27: Transient recorder setup for triggering on voltage events.....	185
Figure 6.28: Transients trigger detection (envelope)	185
Figure 6.29: Transients trigger detection (envelope)	185
Figure 6.30: Mains signalling voltage level limits according to EN50160.....	188
Figure 6.31: Predefined EN50160 recorder configuration.....	189
Figure 7.1: General Recorder setup to allow auto-recording restart, when reaches maximum file length.....	202

Figure 8.1: Battery compartment206
Figure 8.2: Closing the battery compartment cover207
Figure 8.3: PowerView update function209
Figure 8.4: Selecting USB communication209
Figure 8.5: Check for Firmware menu209
Figure 8.6: Check for Firmware menu210
Figure 8.7: New firmware is available for download210
Figure 8.8: FlashMe firmware upgrade software210
Figure 8.9: FlashMe configuration screen.....211
Figure 8.10: FlashMe programming screen212

1 Introduction

Note:

Energy Master XA MI 2884 and Energy Master MI 2883 share the same hardware (HW4.0) and firmware platform. Some functions, like waveform and transient recorder are not available on the Energy Master MI 2883.

Energy Master XA/Energy Master is handheld multifunction instrument for power quality analysis and energy efficiency measurements.



Figure 1.1: Energy Master XA instrument

Product differentiation:

MI 2884/2883 sharing same measuring hardware and firmware platform.

MI 2884 – Class S Power Quality Instrument with transient measurement on measuring board with sampling period 30.6 kHz and waveform registration possibility

MI 2883 – Class S Power Quality Instrument with basic data logging and registration possibility

Note:

The appearance of the product is outwardly the same. The only differences are in the marking labels and the front plates.



Figure 1.2: Front plates and marking labels

2 Main Features

- Full compliance with power quality standard IEC 61000-4-30 Class S.
- Simple and powerful recorder with microSD memory card (sizes up to 32 GB are supported).
- 3 voltage channels with wide measurement range: up to 1000 V_{rms}, CAT III / 1000 V, with support for medium and high voltage systems.
- Simultaneous voltage and current (7 channels) sampling, 16-bit AD conversion for accurate power measurements and minimal phase shift error.
- 4 current channels with support for automatic clamp recognition and range selection.
- Compliance with IEC 61557-12 and IEEE 1459 (Combined, fundamental, nonfundamental power) and IEC 62053-21 (Energy).
- 4.3" TFT colour display.

- Waveform/inrush recorder, which can be triggered on event or alarms, and run simultaneously with general recorder. **Note:** Available at MI 2884 (Energy Master XA)!
- Powerful troubleshooting tools: transient recorder with envelope and level triggering. **Note:** Available at MI 2884 (Energy Master XA)!
- Support for 50Hz and 60Hz measurement
- PC Software **PowerView v3.0** is an integral part of a measuring system which provides easiest way to download, view and analyse measured data or print reports.
 - PowerView v3.0 analyser exposes a simple but powerful interface for downloading instrument data and getting quick, intuitive and descriptive analysis. Interface has been organized to allow quick selection of data using a Windows Explorer-like tree view.
 - User can easily download recorded data, and organize it into multiple sites with many sub-sites or locations.
 - Generate charts, tables and graphs for your power quality data analysing, and create professional printed reports.
 - Export or copy / paste data to other applications (e.g. spreadsheet) for further analysis.
 - Multiple data records can be displayed and analysed simultaneously.
 - Merge different logging data into one measurement, synchronize data recorded with different instruments with time offsets, split logging data into multiple measurements, or extract data of interest.

2.1 Safety considerations

To ensure operator safety while using the Energy Master XA/ Energy Master instruments and to minimize the risk of damage to the instrument, please note the following general warnings:



The instrument has been designed to ensure maximum operator safety. Usage in a way other than specified in this manual may increase the risk of harm to the operator!



Do not use the instrument and/or accessories if any visible damage is noticed!



The instrument contains no user serviceable parts. Only an authorized dealer can carry out service or adjustment!



All normal safety precautions have to be taken in order to avoid risk of electric shock when working on electrical installations!





Only use approved accessories which are available from your distributor!



Instrument contains rechargeable NiMH batteries. The batteries should only be replaced with the same type as defined on the battery placement label or in this manual. Do not use standard batteries while power supply adapter/charger is connected, otherwise they may explode!



Hazardous voltages exist inside the instrument. Disconnect all test leads, remove the power supply cable and switch off the instrument before removing battery compartment cover.

-  **Maximum nominal voltage between any phase and neutral input is 1000 V_{RMS}. Maximum nominal voltage between phases is 1730 V_{RMS}.**
-  **Always short unused voltage inputs (L1, L2, L3) with neutral (N) input to prevent measurement errors and false event triggering due to noise coupling.**
-  **Do not remove microSD memory card while instrument is recording or reading data. Record damage and card failure can occur.**

2.2 Applicable standards

The Energy Master XA/ Energy Master are designed and tested in accordance with the following standards:

<i>Electromagnetic compatibility (EMC)</i>	
EN 61326-2-2: 2021	Electrical equipment for measurement, control and laboratory use – EMC requirements – Part 2-2: Particular requirements - Test configurations, operational conditions and performance criteria for portable test, measuring and monitoring equipment used in low-voltage distribution systems <ul style="list-style-type: none"> • Emission: Class A equipment (for industrial purposes) • Immunity for equipment intended for use in industrial locations
<i>Safety (LVD)</i>	
EN 61010-1: 2010 + A1:2019	Safety requirements for electrical equipment for measurement, control and laboratory use – Part 1: General requirements
EN 61010-2-030: 2021 + A11:2021	Safety requirements for electrical equipment for measurement, control and laboratory use – Part 2-030: Particular requirements for testing and measuring circuits
EN 61010-031: 2015 + A1:2021 + A11:2021	Safety requirements for electrical equipment for measurement, control and laboratory use – Part 031: Safety requirements for hand-held probe assemblies for electrical measurement and test
EN 61010-2-032: 2021 +A11:2021	Safety requirements for electrical equipment for measurement, control and laboratory use Part 032: Particular requirements for hand-held and hand-manipulated current sensors for electrical test and measurement
<i>Measurement methods</i>	
IEC 61000-4-30: 2015 + A1:2021 Class S	Electromagnetic Compatibility (EMC) – Part 4-30: Testing and measurement techniques – Power quality measurement methods

IEC 61557-12: 2018 + A1:2021	Electrical safety in low voltage distribution systems up to 1 000 V a.c. and 1 500 V d.c. - Equipment for testing, measuring or monitoring of protective measures – Part 12: Performance measuring and monitoring devices (PMD)
IEC 61000-4-7: 2002 + A1: 2008	Electromagnetic compatibility (EMC) – Part 4-7: Testing and measurement techniques – General guide on harmonics and inter-harmonics measurements and instrumentation for power supply systems and equipment connected thereto
IEC 61000-4-15: 2010/ISH1:2017	Electromagnetic compatibility (EMC) – Part 4-15: Testing and measurement techniques – Flicker meter – Functional and design specifications
IEC 62053-21: 2020	Electricity metering equipment (a.c.) - Particular requirements - Part 21: Static meters for active energy (classes 1 and 2)
IEC 62053-23: 2020	Electricity metering equipment (a.c.) - Particular requirements - Part 23: Static meters for reactive energy (classes 2 and 3)
IEEE 1459: 2010	IEEE Standard Definitions for the Measurement of Electric Power Quantities Under Sinusoidal, Non-sinusoidal, Balanced, or Unbalanced Conditions
EN 50160: 2010	Voltage characteristics of electricity supplied by public electricity networks
GOST R 54149: 2010	Electric energy. Electromagnetic compatibility of technical equipment. Power quality limits in the public power supply systems

2.2.1.1 Note about EN and IEC standards:

Text of this manual contains references to European standards. All standards of EN 6XXXX (e.g. EN 61010) series are equivalent to IEC standards with the same number (e.g. IEC 61010) and differ only in amended parts required by European harmonization procedure.

2.3 Abbreviations

In this document following symbols and abbreviations are used:

CF_I	Current crest factor, including CF_{Ip} (phase p current crest factor) and CF_{IN} (neutral current crest factor). See 6.1.3 for definition.
CF_U	Voltage crest factor, including CF_{Upq} (phase p to phase q voltage crest factor) and CF_{Up} (phase p to neutral voltage crest factor). See 6.1.2 for definition.
$\pm DPF_{ind/cap}$	Instantaneous phase power displacement (fundamental) power factor or $\cos \varphi$, including $\pm DPF_{pind}$ (phase p power displacement).

Minus sign indicates generated power and plus sign indicates consumed power. Suffix *ind/cap* represents inductive/capacitive character.

Recorded phase displacement (fundamental) power factor or $\cos \varphi$, including $DPF_{ind/cap}^{\pm}$ (phase p power displacement).

$DPF_{ind/cap}^{\pm}$

Minus sign indicates generated power and plus sign indicates consumed power. Suffix *ind/cap* represents inductive/ capacitive character. This parameter is recorded separately for each quadrant as shown on figure. See 6.1.5 for definition.

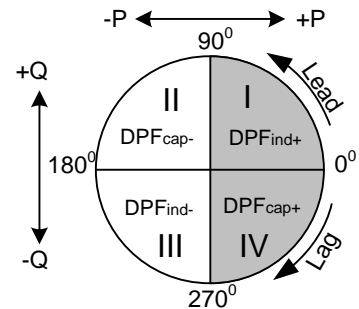

Instantaneous total arithmetic displacement (fundamental) power factor.

$\pm DPF_{totind}$
 $\pm DPF_{totcap}$

Minus sign indicates generated power and plus sign indicates consumed power. Suffix *ind/cap* represents inductive/capacitive character. See 6.1.6 for definition.

Recorded total arithmetic fundamental power factor.

DPF_{totind}^{\pm}
 DPF_{totcap}^{\pm}

Minus sign indicates generated power and plus sign indicates consumed power. Suffix *ind/cap* represents inductive/capacitive character. This parameter is recorded separately as shown on figure. See 6.1.6 for definition.

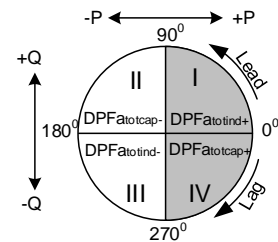

Instantaneous positive sequence total vector displacement (fundamental) power factor.

$\pm DPF_{vtotind}$
 $\pm DPF_{vtotcap}$

Minus sign indicates generated power and plus sign indicates consumed power. Suffix *ind/cap* represents inductive/capacitive character. See 6.1.6 for definition.

Recorded total vector fundamental power factor.

$DPF_{vtotind}^{\pm}$
 $DPF_{vtotcap}^{\pm}$

Minus sign indicates generated power and plus sign indicates consumed power. Suffix *ind/cap* represents inductive/capacitive character. This parameter is recorded separately as shown on figure. See 6.1.6 for definition.

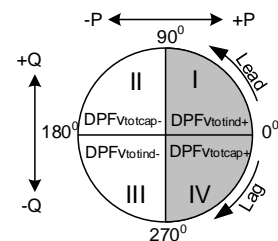

$\pm DPF^+_{totind}$

Instantaneous positive sequence fundamental power factor.

$\pm DPF^+_{totcap}$

	<p>Minus sign indicates generated power and plus sign indicates consumed power. Suffix <i>ind/cap</i> represents inductive/capacitive character. See 6.1.5 for definition.</p>
<p>Recorded total positive sequence fundamental power factor.</p> <p>Minus sign indicates generated power and plus sign indicates consumed power. Suffix <i>ind/cap</i> represents inductive/capacitive character. This parameter is recorded separately as shown on figure. See 6.1.5 for definition.</p>	
<p>$DPF^+_{totind^\pm}$</p> <p>$DPF^+_{totcap^\pm}$</p>	
<p>D_I</p>	<p>Phase current distortion power, including D_{Ip} (phase p current distortion power). See 6.1.5 section: Modern Power measurement for definition.</p>
<p>De_I</p>	<p>Total effective current distortion power. See 6.1.5 section: Modern Power measurement for definition.</p>
<p>DH</p>	<p>Phase harmonics distortion power, including DHp (phase p harmonics distortion power). See 6.1.5 section: Modern Power measurement for definition.</p>
<p>De_H</p>	<p>Total effective harmonics distortion power. See 6.1.5 section: Total nonfundamental power measurements for definition.</p>
<p>Dv</p>	<p>Phase voltage distortion power, including Dvp (phase p voltage distortion power). See 6.1.5 section: Modern Power measurement for definition.</p>
<p>Dev_{tot}</p>	<p>Total effective voltage distortion power. See 6.1.5 section: Modern Power measurement for definition.</p>
<p>Ep^\pm</p>	<p>Recorded phase combined (fundamental and nonfundamental) active energy, including $Ep_p^{+/-}$ (phase p active energy). Minus sign indicates generated energy and plus sign indicates consumed energy. See 6.1.7 for definition.</p>
<p>Ep_{tot}^\pm</p>	<p>Recorded total combined (fundamental and nonfundamental) active energy. Minus sign indicates generated and plus sign indicates consumed energy. See 6.1.7 for definition.</p>
<p>Eq^\pm</p>	<p>Recorded phase fundamental reactive energy, including $Eq_p^{+/-}$ (phase p reactive energy). Minus sign indicates generated and plus sign indicates consumed energy. See 6.1.7 for definition.</p>
<p>Eq_{tot}^\pm</p>	<p>Recorded total fundamental reactive energy. Minus sign indicates generated and plus sign indicates consumed energy. See 6.1.7 for definition.</p>

$f, freq$	Frequency, including $freq_{U12}$ (voltage frequency on U_{12}), $freq_{U1}$ (voltage frequency on U_1 and $freq_{I1}$ (current frequency on I_1). See 6.1.4 for definition.
i^-	Negative sequence current ratio (%). See 6.1.11 for definition.
i^0	Zero sequence current ratio (%). See 6.1.11 for definition.
i^+	Positive sequence current component on three phase systems. See 6.1.11 for definition.
i^-	Negative sequence current component on three phase systems. See 6.1.11 for definition.
i^0	Zero sequence current components on three phase systems. See 6.1.11 for definition.
$I_{Rms(1/2)}$	RMS current measured over 1 cycle, commencing at a fundamental zero crossing on an associated voltage channel, and refreshed each half-cycle, including $I_{pRms(1/2)}$ (phase p current), $I_{NRms(1/2)}$ (neutral RMS current)
I_{fund}	Fundamental RMS current I_{h1} (on 1 st harmonics), including I_{fund_p} (phase p fundamental RMS current) and I_{fund_N} (neutral RMS fundamental current). See 6.1.8 for definition
I_{h_n}	n^{th} current RMS harmonic component including $I_{p h_n}$ (phase p; n^{th} RMS current harmonic component) and $I_{N h_n}$ (neutral n^{th} RMS current harmonic component). See 6.1.8 for definition
$I_{i h_n}$	n^{th} current RMS inter-harmonic component including $I_{p i h_n}$ (phase p; n^{th} RMS current inter-harmonic component) and $I_{N i h_n}$ (neutral n^{th} RMS current inter-harmonic component). See 6.1.8 for definition
I_{Nom}	Nominal current. Current of clamp-on current sensor for 1 Vrms at output.
I_{Pk}	Peak current, including I_{pPk} (phase p current) including I_{NPK} (neutral peak current)
I_{Rms}	RMS current, including I_{pRms} (phase p current), I_{NRms} (neutral RMS current). See 6.1.3 for definition.
$\pm P$	Instantaneous phase active combined (fundamental and nonfundamental) power, including $\pm P_p$ (phase p active power). Minus sign indicates generated and plus sign indicates consumed power. See 6.1.5 for definitions.
p^\pm	Recorded phase active (fundamental and nonfundamental) power, including P_p^\pm (phase p active power). Minus sign

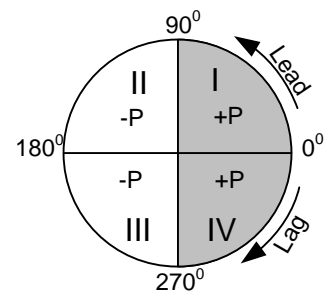

indicates generated and plus sign indicates consumed power. See 6.1.5 for definitions.

$\pm P_{tot}$	Instantaneous total active combined (fundamental and nonfundamental) power. Minus sign indicates generated and plus sign indicates consumed power. See 6.1.5 for definitions.	
P_{tot}^{\pm}	Recorded total active (fundamental and nonfundamental) power. Minus sign indicates generated and plus sign indicates consumed power. See 6.1.5 for definitions.	
$\pm P_{fund}$	Instantaneous active fundamental power, including $\pm P_{fund_p}$ (phase p active fundamental power). Minus sign indicates generated and plus sign indicates consumed power. See 6.1.5 for definitions.	
P_{fund}^{\pm}	Recorded phase active fundamental power, including $P_{fund_p}^{\pm}$ (phase p active fundamental power). Minus sign indicates generated and plus sign indicates consumed power. See 6.1.5 for definitions.	
$\pm P^+, \pm P_{tot}^+$	Instantaneous positive sequence of total active fundamental power. Minus sign indicates generated and plus sign indicates consumed power. See 6.1.5 for definitions.	
$P_{tot}^{+\pm}$	Recorded positive sequence of total active fundamental power. Minus sign indicates generated and plus sign indicates positive sequence of consumed power. See 6.1.5 for definitions.	
$\pm P_H$	Instantaneous phase active harmonic power, including $\pm P_{Hp}$ (phase p active harmonic power). Minus sign indicates generated and plus sign indicates consumed power. See 6.1.5 for definitions.	
P_H^{\pm}	Recorded phase active harmonics power, including P_{Hp}^{\pm} (phase p active harmonic power). Minus sign indicates generated and plus sign indicates consumed power. See 6.1.5 for definitions.	
$\pm P_{Htot}$	Instantaneous total active harmonic power. Minus sign indicates generated and plus sign indicates consumed power. See 6.1.5 for definitions.	

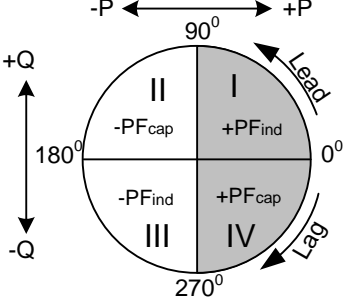
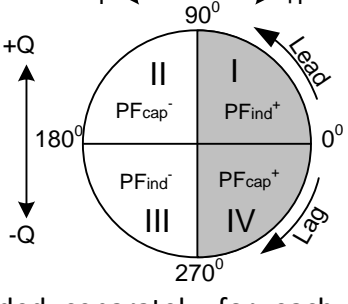
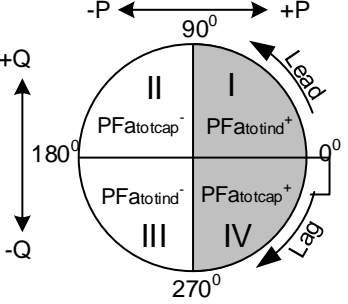
P_{Htot}^{\pm}	<p>Recorded total active harmonics power. Minus sign indicates generated and plus sign indicates consumed active power. See 6.1.5 for definitions.</p>
$\pm PF_{ind}$ $\pm PF_{cap}$	<p>Instantaneous phase combined (fundamental and nonfundamental) power factor, including $\pm PF_{pind/cap}$ (phase p power factor). Minus sign indicates generated power and plus sign indicates consumed power. Suffix <i>ind/cap</i> represents inductive/capacitive character.</p> <p>Note: PF = DPF when harmonics are not present. See 6.1.5 for definition.</p> 
PF_{ind}^{\pm} PF_{cap}^{\pm}	<p>Recorded phase combined (fundamental and nonfundamental) power factor.</p> <p>Minus sign indicates generated power and plus sign indicates consumed power. Suffix <i>ind/cap</i> represents inductive/ capacitive character. This parameter is recorded separately for each quadrant as shown on figure.</p> 
$\pm PFA_{totind}$ $\pm PFA_{totcap}$	<p>Instantaneous total arithmetic combined (fundamental and nonfundamental) power factor.</p> <p>Minus sign indicates generated power and plus sign indicates consumed power. Suffix <i>ind/cap</i> represents inductive/capacitive character. See 6.1.6 for definition.</p>
PFA_{totind}^{\pm} PFA_{totcap}^{\pm}	<p>Recorded total arithmetic combined (fundamental and nonfundamental) power factor.</p> <p>Minus sign indicates generated power and plus sign indicates consumed power. Suffix <i>ind/cap</i> represents inductive/capacitive character. This parameter is recorded separately for each quadrant as shown on figure.</p> 
$\pm PFE_{totind}$ $\pm PFE_{totcap}$	<p>Instantaneous total effective combined (fundamental and nonfundamental) power factor.</p> <p>Minus sign indicates generated power and plus sign indicates consumed power. Suffix <i>ind/cap</i> represents inductive/capacitive character. See 6.1.5 for definition.</p>

PFE_{totind}^{\pm} PFE_{totcap}^{\pm}	<p>Recorded total effective combined (fundamental and nonfundamental) power factor.</p> <p>Minus sign indicates generated power and plus sign indicates consumed power. Suffix <i>ind/cap</i> represents inductive/capacitive character. This parameter is recorded separately for each quadrant as shown on figure.</p>	
$\pm PFV_{totind}$ $\pm PFV_{totcap}$	<p>Instantaneous total vector combined (fundamental and nonfundamental) power factor.</p> <p>Minus sign indicates generated power and plus sign indicates consumed power. Suffix <i>ind/cap</i> represents inductive/capacitive character. See 6.1.6 for definition.</p>	
PFV_{totind}^{\pm} PFV_{totcap}^{\pm}	<p>Recorded total vector combined (fundamental and nonfundamental) power factor.</p> <p>Minus sign indicates generated power and plus sign indicates consumed power. Suffix <i>ind/cap</i> represents inductive/capacitive character. This parameter is recorded separately for each quadrant as shown on figure.</p>	
P_{lt}	<p>Phase long term flicker (2 hours), including P_{ltpg} (phase p to phase g long term voltage flicker) and P_{ltp} (phase p to neutral long-term voltage flicker). See 6.1.10 for definition.</p>	
P_{st}	<p>Short term flicker (10 minutes) including P_{stpg} (phase p to phase g short term voltage flicker) and P_{stp} (phase p to neutral voltage flicker). See 6.1.10 for definition.</p>	
$P_{st(1min)}$	<p>Short term flicker (1 minute) including $P_{st(1min)pg}$ (phase p to phase g short term voltage flicker) and $P_{st(1min)p}$ (phase p to neutral voltage flicker). See 6.1.10 for definition.</p>	
P_{inst}	<p>Instantaneous flicker including P_{instpg} (phase p to phase g instantaneous voltage flicker) and P_{instp} (phase p to instantaneous voltage flicker). See 6.1.10 for definition.</p>	
$\pm N$	<p>Instantaneous combined (fundamental and nonfundamental) nonactive phase power including $\pm N_p$ (phase p nonactive phase power). Minus sign indicates generated and plus sign indicate consumed nonactive power. See 6.1.5 for definition.</p>	

N_{ind}^{\pm} N_{cap}^{\pm}	<p>Recorded phase combined (fundamental and nonfundamental) nonactive power including $N_{cap/indp}$ (phase p nonactive phase power). Suffix <i>ind/cap</i> represents inductive/capacitive character. Minus sign indicates generated and plus sign indicates consumed fundamental reactive power. This parameter is recorded separately for each quadrant as shown on figure. See 6.1.5 for definition.</p>	
$\pm N_{tot}$	<p>Instantaneous combined (fundamental and nonfundamental) nonactive total vector power. Minus sign indicates generated and plus sign indicate consumed nonactive power. See 6.1.5 for definition.</p>	
N_{totind}^{\pm} N_{totcap}^{\pm}	<p>Recorded total vector combined (fundamental and nonfundamental) nonactive power. Suffix <i>ind/cap</i> represents inductive/capacitive character. Minus sign indicates generated and plus sign indicates consumed combined nonactive power. This parameter is recorded separately for each quadrant as shown on figure. See 6.1.5 for definition.</p>	
$\pm Na_{tot}$	<p>Instantaneous combined (fundamental and nonfundamental) nonactive total arithmetic power. Minus sign indicates generated and plus sign indicate consumed nonactive power. See 6.1.6 for definition.</p>	
Na_{totind}^{\pm} Na_{totcap}^{\pm}	<p>Recorded total arithmetic combined (fundamental and nonfundamental) nonactive power. Minus sign indicates generated and plus sign indicates consumed combined nonactive power. This parameter is recorded separately for generated and consumed nonactive power.</p>	
$\pm Q_{fund}$	<p>Instantaneous fundamental reactive phase power including $\pm Q_p$ (phase p reactive phase power). Minus sign indicates generated and plus sign indicates consumed fundamental reactive power. See 6.1.5 for definition.</p>	

$Qfund_{ind}^{\pm}$ $Qfund_{cap}^{\pm}$	<p>Recorded phase fundamental reactive power. Suffix <i>ind/cap</i> represents inductive/capacitive character. Minus sign indicates generated and plus sign indicates consumed fundamental reactive power. This parameter is recorded separately for each quadrant as shown on figure. See 6.1.5 for definition.</p>	
$\pm Qvfund_{tot}$	<p>Instantaneous fundamental total vector reactive power. Minus sign indicates generated and plus sign indicates consumed fundamental reactive power. See 6.1.6 for definition.</p>	
$Qvfund_{totind}^{\pm}$ $Qvfund_{totcap}^{\pm}$	<p>Recorded total fundamental vector reactive power. Suffix <i>ind/cap</i> represents inductive/capacitive character. Minus sign indicates generated and plus sign indicates consumed fundamental reactive power. This parameter is recorded separately for each quadrant as shown on figure. See 6.1.6 for definition.</p>	
$Qafund_{tot}$	<p>Instantaneous fundamental total arithmetic reactive power. See 6.1.6 for definition.</p>	
$Qafund_{tot}$ $Qafund_{tot}$	<p>Recorded fundamental total arithmetic reactive power. See 6.1.6 for definition.</p>	
$\pm Q^+_{totcap}$ $\pm Q^+_{totind}$	<p>Instantaneous positive sequence of total fundamental reactive power. Suffix <i>ind/cap</i> represents inductive/ capacitive character. Minus sign indicates generated and plus sign indicates consumed reactive power. See 6.1.5 for definition.</p>	
$Q^+_{totind}^{\pm}$ $Q^+_{totcap}^{\pm}$	<p>Recorded positive sequence of total fundamental reactive power. Suffix <i>ind/cap</i> represents inductive/capacitive character. Minus sign indicates generated and plus sign indicates consumed reactive power. This parameter is recorded separately for each quadrant.</p>	
S	<p>Combined (fundamental and nonfundamental) phase apparent power including S_p (phase p apparent power). See 6.1.5 for definition.</p>	
Sa_{tot}	<p>Combined (fundamental and nonfundamental) total arithmetic apparent power. See 6.1.6 for definition.</p>	
Se_{tot}	<p>Combined (fundamental and nonfundamental) total effective apparent power. See 6.1.5 for definition.</p>	

SV_{tot}	Combined (fundamental and nonfundamental) total vector apparent power. See 6.1.6 for definition.
$Sfund$	Phase fundamental apparent power, including $Sfund_p$ (phase p fundamental apparent power). See 6.1.5 for definition.
$Safund_{tot}$	Fundamental total arithmetic apparent power. See 6.1.6 for definition.
$Svfund_{tot}$	Fundamental total vector apparent power. See 6.1.6 for definition.
S^+_{tot}	Positive sequence of total fundamental apparent power. See 6.1.5 for definition.
$Sufund_{tot}$	Unbalanced fundamental apparent power. See 6.1.5 for definition.
SN	Phase nonfundamental apparent power, including SN_p (phase p nonfundamental apparent power). See 6.1.5 for definition.
Sen	Total nonfundamental effective apparent power. See 6.1.5 for definition.
SH	Phase harmonic apparent power, including SH_p (phase p harmonic apparent power). See 6.1.5 for definition.
SeH_{tot}	Total harmonic effective apparent power. See 6.1.5 for definition.
THD_I	Total harmonic distortion current (in % or A), including THD_{Ip} (phase p current THD) and THD_{IN} (neutral current THD). See 6.1.8 for definition
THD_U	Total harmonic distortion voltage related (in % or V) including THD_{Upg} (phase p to phase g voltage THD) and THD_{Up} (phase p to neutral voltage THD). See 6.1.11 for definition.
u^-	Negative sequence voltage ratio (%). See 6.1.11 for definition.
u^0	Zero sequence voltage ratio (%). See 6.1.11 for definition.
U, U_{Rms}	RMS voltage, including U_{pg} (phase p to phase g voltage) and U_p (phase p to neutral voltage). See 6.1.2 for definition.
U^+	Positive sequence voltage component on three phase systems. See 6.1.11 for definition.
U^-	Negative sequence voltage component on three phase systems. See 6.1.11 for definition.
U^0	Zero sequence voltage component on three phase systems. See 6.1.11 for definition.
U_{Dip}	Minimal $U_{Rms(1/2)}$ voltage measured during dip occurrence
$Ufund$	Fundamental RMS voltage (U_{h1} on 1 st harmonics), including $Ufund_{pg}$ (phase p to phase g fundamental RMS voltage) and

	U_{fund_p} (phase p to neutral fundamental RMS voltage). See 6.1.8 for definition
U_{h_N}	n^{th} voltage RMS harmonic component including $U_{pg h_N}$ (phase p to phase g voltage n^{th} RMS harmonic component) and $U_{p h_N}$ (phase p to neutral voltage n^{th} RMS harmonic component). See 6.1.8 for definition.
U_{ih_N}	n^{th} voltage RMS interharmonic voltage component including $U_{pg ih_N}$ (phase p to phase g voltage n^{th} RMS interharmonic component) and $U_{p ih_N}$ (phase p to neutral voltage n^{th} RMS interharmonic component). See 6.1.8 for definition.
U_{Int}	Minimal $U_{Rms(1/2)}$ voltage measured during interrupt occurrence.
U_{Nom}	Nominal voltage, normally a voltage by which network is designated or identified.
U_{Over}	Voltage over-deviation, difference between the measured value and the nominal value of a voltage, only when the measured value is greater than the nominal value. Voltage over-deviation measured over recorded interval, expressed in % of nominal voltage including $U_{pg Over}$ (phase p to phase g voltage) and $U_{p Over}$ (phase p to neutral voltage). See 6.1.12 for details.
U_{Pk}	Peak voltage, including $U_{pg Pk}$ (phase p to phase g voltage) and $U_{p Pk}$ (phase p to neutral voltage)
$U_{Rms(1/2)}$	RMS voltage refreshed each half-cycle, including $U_{pg Rms(1/2)}$ (phase p to phase g half-cycle voltage) and $U_{p Rms(1/2)}$ (phase p to neutral half-cycle voltage). See 6.1.12 for definition.
U_{Swell}	Maximal $U_{Rms(1/2)}$ voltage measured during swell occurrence.
U_{Sig}	Mains signalling RMS voltage, including $U_{Sig pg}$ (phase p to phase g half-cycle signalling voltage) and $U_{Sig p}$ (phase p to neutral half-cycle signalling voltage). Signalling is a burst of signals, often applied at a non-harmonic frequency, that remotely control equipment. See 6.2.6 for details.
U_{Under}	Voltage under-deviation, difference between the measured value and the nominal value of a voltage, only when the voltage is lower than the nominal value. Voltage under-deviation measured over recorded interval and expressed in % of nominal voltage, including $U_{pg Under}$ (phase p to phase g voltage) and $U_{p Under}$ (phase p to neutral voltage). See 6.1.12 for details.
ΔU_{max}	Maximum absolute difference between any of the $U_{Rms(1/2)}$ values during the RVC event and the final arithmetic mean 100/120 $U_{Rms(1/2)}$ value just prior to the RVC event. For poly-phase systems, the ΔU_{max} is the largest ΔU_{max} on any channel. See 6.1.15 for details.

ΔU_{ss}

Absolute difference between the final arithmetic mean 100/120 $U_{Rms(1/2)}$ value just prior to the RVC event and the first arithmetic mean 100/120 $U_{Rms(1/2)}$ value after the RVC event. For poly-phase systems, the ΔU_{ss} is the largest ΔU_{ss} on any channel. See 6.1.15 for details.

3 Description

3.1 Front panel



Figure 3.1: Front panel

Front panel layout:

- | | |
|------------------|---|
| 1. LCD | Colour TFT display, 4.3-inch, 480 x 272 pixels. |
| 2. F1 – F4 | Function keys. |
| 3. ARROW keys | Moves cursor and select parameters. |
| 4. ENTER key | Step into submenu. |
| 5. ESC key | Exits any procedure, confirms new settings. |
| 6. SHORTCUT keys | Quick access to main instrument functions. |

- | | |
|------------------------------------|--|
| 7. LIGHT key
(BEEP OFF) | Adjust LCD backlight intensity: high/low//off
If the <i>LIGHT</i> key is pressed for more than 1.5 seconds, beeper will be disabled. Press & hold again to enable it. |
| 8. ON-OFF key | Turns on/off the instrument. |
| 9. COVER | Communication ports and microSD card slot protection. |

3.2 Connector panel

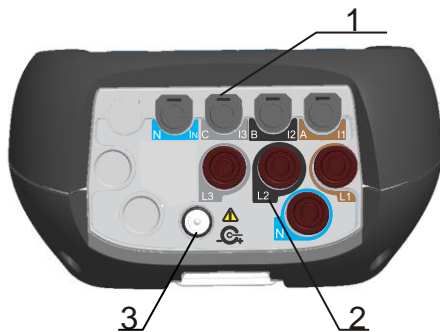

⚠ Warnings!

- ⚠ Use safety test leads only!
- ⚠ Max. permissible nominal voltage between voltage input terminals and ground is 1000 V_{RMS}!
- ⚠ Max. short-term voltage of external power supply adapter is 14 V!

Figure 3.2: Top connector panel

Top connector panel layout:

- 1 Clamp-on current transformers (I₁, I₂, I₃, I_N) input terminals.
- 2 Voltage (L₁, L₂, L₃, N) input terminals.
- 3 12 V external power socket.

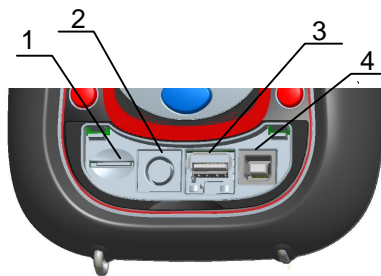

Figure 3.3: Side connector panel

Side connector panel layout:

- 1 MicroSD card slot.
- 2 Serial connector
- 3 Ethernet connector – **not in use.**
- 4 USB connector.

3.3 Bottom view

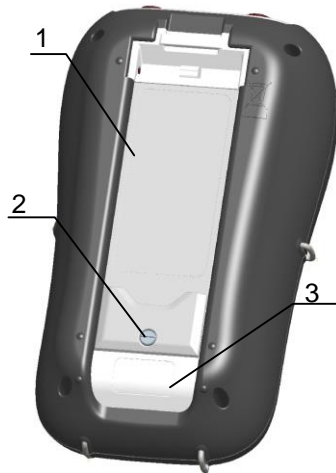

Figure 3.4: Bottom view

Bottom view layout:

1. Battery compartment cover.
2. Battery compartment screw (unscrew to replace the batteries).
3. Serial number label.

3.4 Accessories

3.4.1 Standard accessories

Table 3.1: Energy Master XA/Energy Master standard accessories

Description	Pieces
Flexible current clamp 3000 A / 300 A / 30 A (A 1227 or A 1502)	3
Colour coded test probe	4
Colour coded crocodile clip	4
Colour coded voltage measurement lead	4
USB cable	1
12 V / 1.2 A Power supply adapter	1
NiMH rechargeable battery, type HR 6 (AA)	6
Soft carrying bag	1
Compact disc (CD) with PowerView v3.0 and manuals	1

3.4.2 Optional accessories

See the attached sheet for a list of optional accessories that are available on request from your distributor.

4 Operating the instrument

This section describes how to operate the instrument. The instrument front panel consists of a colour LCD display and keypad. Measured data and instrument status are shown on the display. Basic display symbols and keys description is shown on figure below.



Figure 4.1: Display symbols and keys description

During measurement campaign various screens can be displayed. Most screens share common labels and symbols. These are shown on figure below.

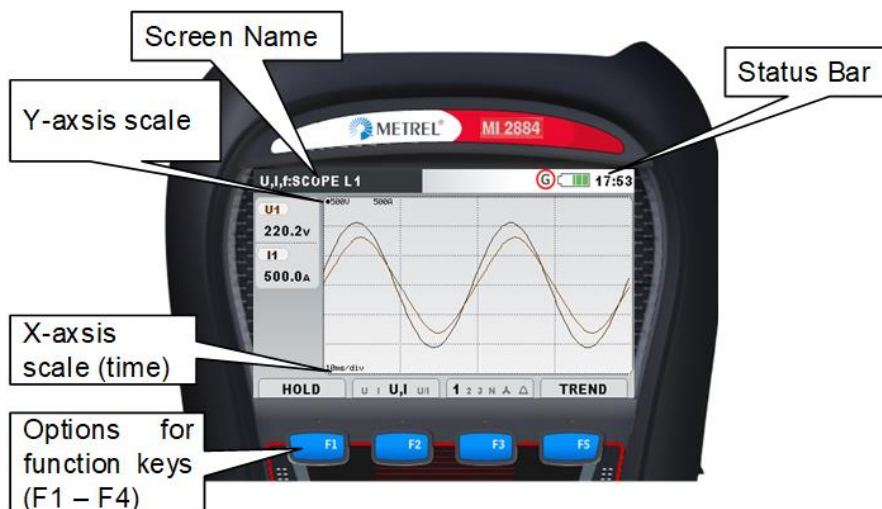

Figure 4.2: Common display symbols and labels during measurement campaign















4.1 Instrument status bar

Instruments status bar is placed on the top of the screen. It indicates different instrument states. Icon descriptions are shown on table below.



Figure 4.3: Instrument status bar

Table 4.1: Instrument status bar description

	Indicates battery charge level.
	Indicates that charger is connected to the instrument. Batteries will be charged automatically when charger is present.
	Instrument is locked (see section 4.22.4 for details).
	AD converter over range. Selected Nominal voltage or current clamps range is too small.
09:19	Current time.
	One of the current clamps has opposite direction from the expected.
	Recorder status:
	General recorder is active, waiting for trigger.
	General recorder is active, recording in progress.
	Waveform recorder is active, waiting for trigger; available only for MI 2884
	Waveform recorder is active, recording in progress; available only for MI 2884
	Transient recorder is active, waiting for trigger; available only for MI 2884
	Transient recorder is active, recording in progress; available only for MI 2884
	Memory list recall. Shown screen is recalled from instrument memory.
	Flagged data mark. While observing recorded data this mark will indicate that observed measurement results for given time interval can be compromised due to interrupt, dip or swells occurrence. See section 6.1.17 for further explanation.
	Signalling voltage is present on voltage line at monitored frequencies. See sections 4.13 and 4.21.4 for further explanation.
	One of the current clamps has opposite direction from the expected.



USB stick communication mode. In this mode selected record can be transferred from microSD card to USB stick. USB communication with PC is disabled while in this mode. See section 4.20 for details.

4.2 Instrument keys











Instrument keyboard is divided into four subgroups:

- Function keys
- Shortcut keys
- Menu/zoom manipulation keys: Cursors, Enter, Escape
- Other keys: Light and Power on/off keys

Function keys     are multifunctional. Their current function is shown at the bottom of the screen and depends on selected instrument function.

Shortcut keys are shown in table below. They provide quick access to the most common instrument functions.

Table 4.2: Shortcut Keys and other Function keys

	Shows UIF Meter screen from MEASUREMENT submenu
	Shows Power meter screen from MEASUREMENT submenu
	Shows Harmonics meter screen from MEASUREMENT submenu
	Shows Connection Setup screen from MEASUREMENT SETUP submenu
	Shows Phase diagram screen from MEASUREMENT submenu
	Hold  key for 2 seconds to trigger WAVEFORM SNAPSHOT. Instrument will record all measured parameters into file, which can be then analysed by PowerView.
	Set backlight intensity (high/low/off).
	Hold  key for 2 s to disable/enable beeper sound signals.
	Switch On/off the instrument. Note: instrument will not power off if any recorder is active. Note: Hold key for 5 seconds in order to reset instrument, in case of failure.

Cursor, Enter and Escape keys are used for moving through instrument menu structure, entering various parameters. Additionally, cursor keys are used for zooming graphs and moving graph cursors.

4.3 Instrument memory (microSD card)

Energy Master XA/Energy Master use microSD card for storing records. Prior instrument use, microSD card should be formatted to a single partition FAT32 file system and inserted into the instrument, as shown on figure below.

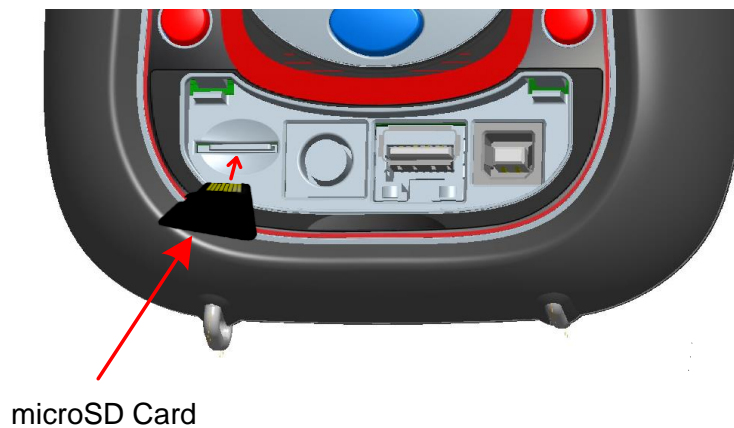

Figure 4.4: Inserting microSD card

1. Open instrument cover
2. Insert microSD card into a slot on the instrument (card should be putted upside down, as shown on figure)
3. Close instrument cover

Note: Do not turn off the instrument while microSD card is accessed:

- during record session
- observing recorded data in MEMORY LIST menu

Doing so may cause data corruption, and permanent data lost.

Note: SD Card should have single FAT32 partition. Do not use SD cards with multiple partitions.

4.4 Instrument Main Menu

After powering on the instrument, the “MAIN MENU” is displayed. From this menu all instrument functions can be selected.

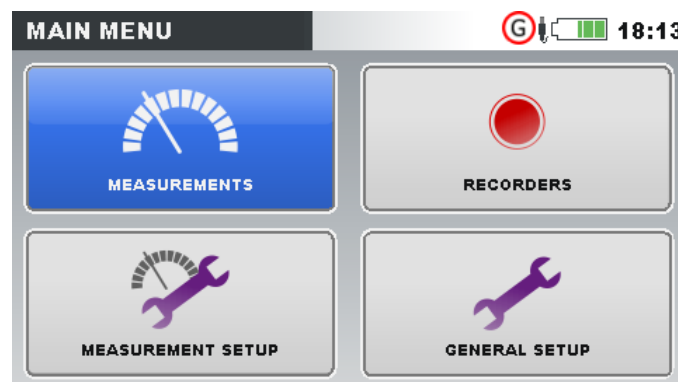

Figure 4.5: “MAIN MENU”

Table 4.3: Instrument Main menu







	MEASUREMENT submenu. Provide access to various instrument measurement screens
	RECORDER submenu. Provide access to instrument recorders configuration and storage.
	MEASUREMENT SETUP submenu. Provide access to the measurement settings.
	GENERAL SETUP submenu. Provide access to the various instrument settings.

Table 4.4: Keys in Main menu

	Selects submenu.
	Enters selected submenu.

4.4.1 Instrument submenus

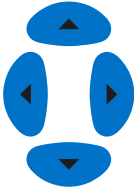
By pressing ENTER key in Main menu, user can select one of four submenus:

- Measurements – set of basic measurement screens,
- Recorders – setup and view of various recordings,
- Measurement setup – measurement parameters setup,
- General setup – configuring common instrument settings.

List of all submenus with available functions are presented on following figures.

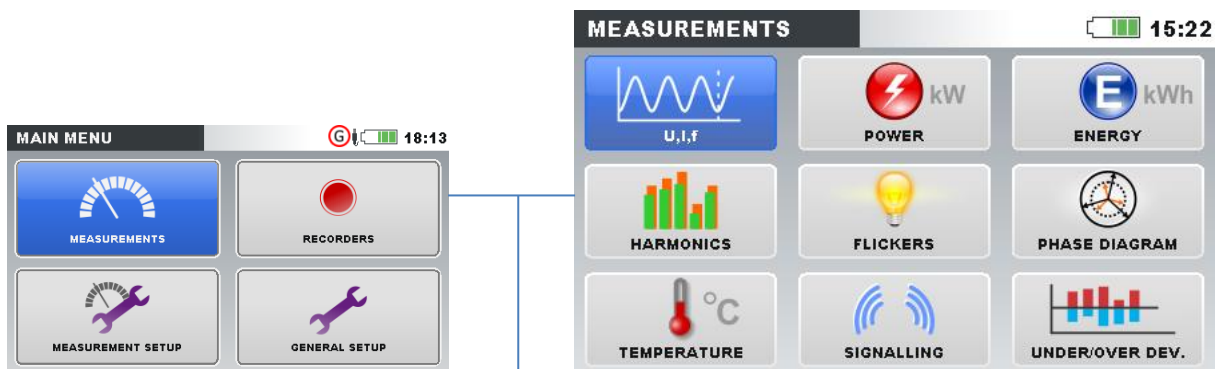

Figure 4.6: Measurements submenu

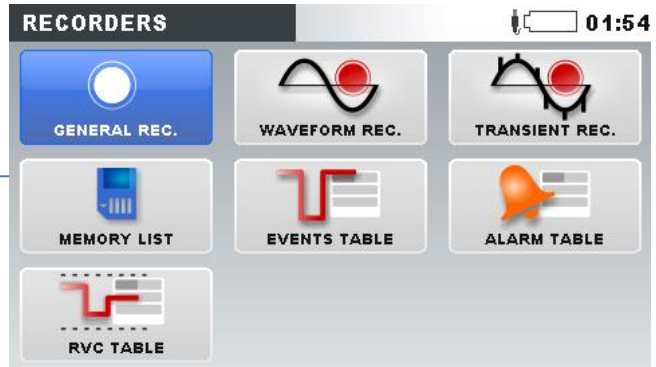

Figure 4.7: Recorders submenu – MI 2884



Figure 4.8: Recorders submenu – MI 2883

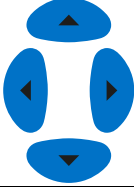



Figure 4.9: Measurement setup submenu



Figure 4.10: General setup submenu

Table 4.5: Keys in submenus

	Selects function within each submenu.
	Enters selected function.
	Returns to the "MAIN MENU".

4.5 U, I, f

Voltage, current and frequency parameters can be observed in the "U, I, f" screens. Measurement results can be viewed in a tabular (METER) or a graphical form (SCOPE, TREND). TREND view is active only in RECORDING mode. See section 4.14 for details.

4.5.1 Meter

By entering U, I, f option, the U, I, f – METER tabular screen is shown (see figures below).

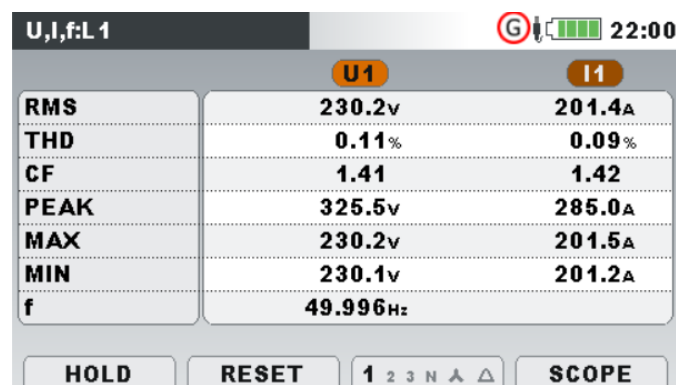

U,I,f:L 1		G [Battery Icon] 22:00	
	U1	I1	
RMS	230.2v	201.4A	
THD	0.11%	0.09%	
CF	1.41	1.42	
PEAK	325.5v	285.0A	
MAX	230.2v	201.5A	
MIN	230.1v	201.2A	
f	49.996Hz		

HOLD RESET 1 2 3 N A Δ SCOPE

Figure 4.11: U, I, f meter phase table screens (L1, L2, L3, N)



U,I,f:人		[Battery Icon] 10:51			
	L1	L2	L3	N	
UL	230.1	229.8	230.2v		
ThdU	0.10	0.11	0.12%		
IL	100.6	100.6	100.6A	2.493A	
Thdl	0.14	0.14	0.14%	466.5%	
f	49.996 Hz				

HOLD [] 1 2 3 N 人 Δ SCOPE

	L12	L23	L31
UL	398.4	398.4	398.4V
ThdU	0.17	0.17	0.17%
IL	4.996	3.996	4.578A
ThdI	0.09	0.09	0.08%
f	50.000		Hz

Figure 4.12: U, I, f meter summary table screens

In those screens on-line voltage and current measurements are shown. Descriptions of symbols and abbreviations used in this menu are shown in table below.

Table 4.6: Instrument screen symbols and abbreviations

RMS	
UL	True effective value U_{Rms} and I_{Rms}
IL	
THD	
ThdU	Total harmonic distortion THD_U and THD_I
ThdI	
CF	Crest factor CF_U and CF_I
PEAK	Peak value U_{Pk} and I_{Pk}
MAX	Maximal $U_{Rms(1/2)}$ voltage and maximal $I_{Rms(1/2)}$ current, measured after RESET (key: F2)
MIN	Minimal $U_{Rms(1/2)}$ voltage and minimal $I_{Rms(1/2)}$ current, measured after RESET (key: F2)
f	Frequency on reference channel





Note: In case of overloading current or overvoltage on AD converter, icon  will be displayed in the status bar of the instrument.

Table 4.7: Keys in Meter screens

	HOLD	Holds measurement on display. Hold clock time will be displayed in the right top corner.
	RUN	Runs held measurement.
	RESET	Resets MAX and MIN values ($U_{Rms(1/2)}$ and $I_{Rms(1/2)}$).
	1 2 3 N ^ Δ	Shows measurements for phase L1.
	1 2 3 N ^ Δ	Shows measurements for phase L2.
	1 2 3 N ^ Δ	Shows measurements for phase L3.

	Shows measurements for neutral channel.
	Shows measurements for all phases.
	Shows measurements for all phase-to-phase voltages.
	Shows measurements for phase-to-phase voltage L12.
	Shows measurements for phase-to-phase voltage L23.
	Shows measurements for phase-to-phase voltage L31.
	Shows measurements for all phase-to-phase voltages.
	Switches to METER view.
	Switches to SCOPE view.
	Switches to TREND view (available only during recording).
	Triggers Waveform snapshot.
	Returns to the "MEASUREMENTS" submenu.

4.5.2 Scope

Various combinations of voltage and current waveforms can be displayed on the instrument, as shown below.

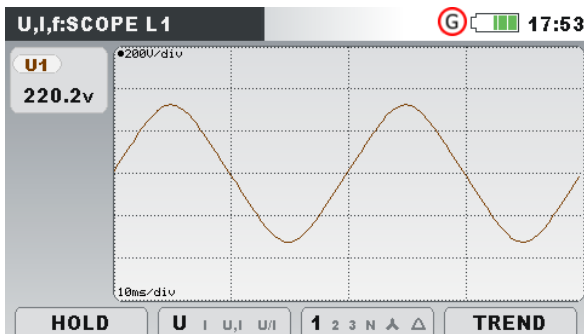

Figure 4.13: Voltage only waveform

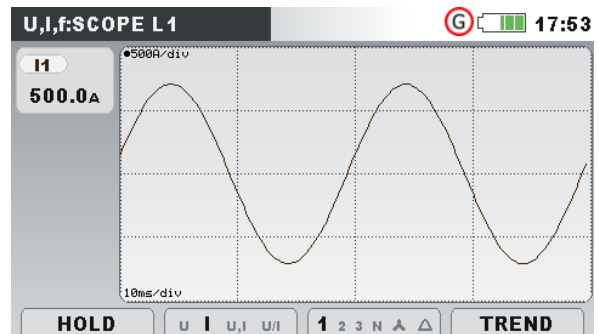

Figure 4.14: Current only waveform

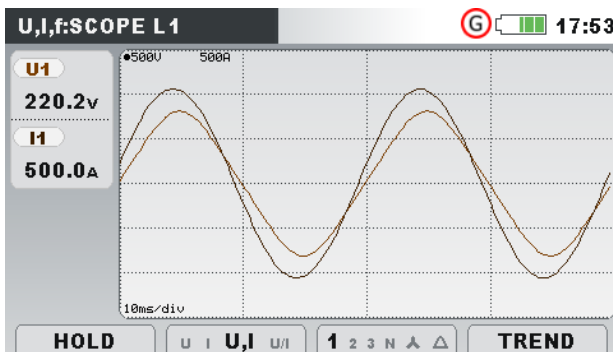

Figure 4.15: Voltage and current waveform (single mode)

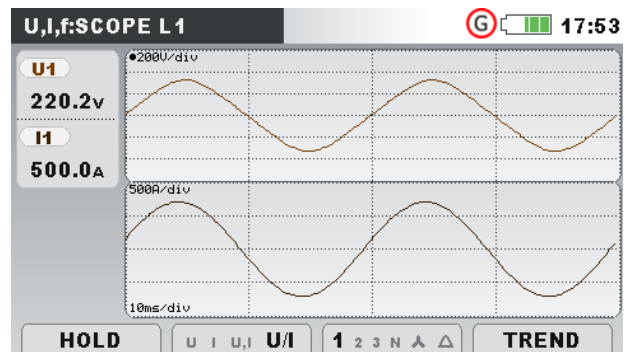











Figure 4.16: Voltage and current waveform (dual mode)

Table 4.8: Instrument screen symbols and abbreviations

U1, U2, U3	True effective value of phase voltage: U ₁ , U ₂ , U ₃
U12, U23, U31	True effective value of phase-to-phase (line) voltage: U ₁₂ , U ₂₃ , U ₃₁
I1, I2, I3, I _N	True effective value of current: I ₁ , I ₂ , I ₃ , I _N

Table 4.9: Keys in Scope screens

	HOLD	Holds measurement on display.
	RUN	Runs held measurement.
	U U, I U/I	Selects which waveforms to show: Shows voltage waveform.
	I U, I U/I	Shows current waveform.
	U U , I U/I	Shows voltage and current waveform (single graph).
	U U , I U /I	Shows voltage and current waveform (dual graph).
		Selects between phase, neutral, all-phases and line view:
	1 2 3 N ^ Δ	Shows waveforms for phase L1.
	1 2 3 N ^ Δ	Shows waveforms for phase L2.
	1 2 3 N ^ Δ	Shows waveforms for phase L3.
	1 2 3 N ^ Δ	Shows waveforms for neutral channel.
	1 2 3 N ^ Δ	Shows all phase waveforms.
	1 2 3 N ^ Δ	Shows all phase-to-phase waveforms.
	12 23 31 Δ	Shows waveforms for phase L12.
	12 23 31 Δ	Shows waveforms for phase L23.
	12 23 31 Δ	Shows waveforms for phase L31.
12 23 31 Δ	Shows all phase waveforms.	
	METER	Switches to METER view.
	SCOPE	Switches to SCOPE view.
	TREND	Switches to TREND view (available only during recording).
		Selects which waveform to zoom (only in U/I or U+I).
		Sets vertical zoom.
		Sets horizontal zoom.
		Triggers Waveform snapshot.
		Returns to the "MEASUREMENTS" submenu.

4.5.3 Trend

While GENERAL RECORDER is active, TREND view is available (see section 4.14 for instructions how to start recorder).

4.5.3.1 Voltage and current trends

Current and voltage trends can be observed by cycling function key F4 (METER-SCOPE-TREND).

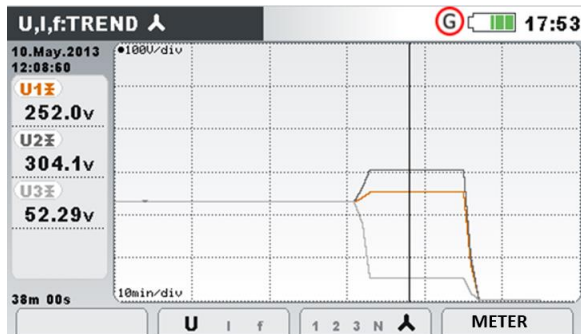

Figure 4.17: Voltage trend (all voltages)

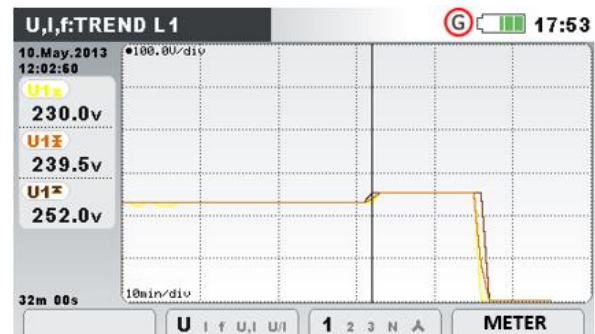

Figure 4.18: Voltage trend (single voltage)

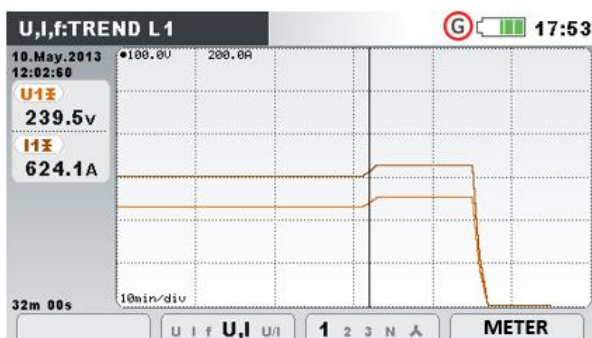

Figure 4.19: Voltage and current trend (single mode)

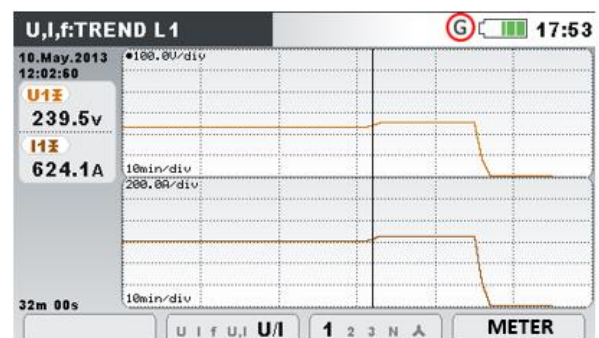

Figure 4.20: Voltage and current trend (dual mode)

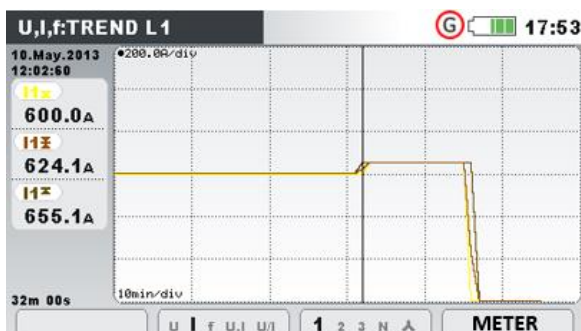

Figure 4.21: Trends of all currents

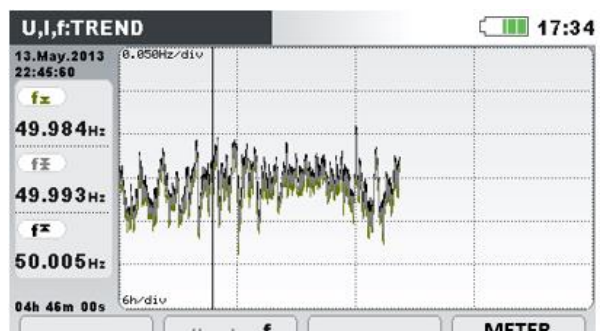







Figure 4.22: Frequency trend

Table 4.10: Instrument screen symbols and abbreviations

U1, U2, U3, U12, U23, U31	Maximal ($\mathbf{\bar{U}}$), average ($\mathbf{\bar{U}}$) and minimal ($\mathbf{\underline{U}}$) value of phase RMS voltage U ₁ , U ₂ , U ₃ or line voltage U ₁₂ , U ₂₃ , U ₃₁ for time interval (IP) selected by cursor.
I1, I2, I3, In	Maximal ($\mathbf{\bar{I}}$), average ($\mathbf{\bar{I}}$) and minimal ($\mathbf{\underline{I}}$) value of current I ₁ , I ₂ , I ₃ , I _N for time interval (IP) selected by cursor.
f	Maximal ($\mathbf{\bar{f}}$), active average ($\mathbf{\bar{f}}$) and minimal ($\mathbf{\underline{f}}$) value of frequency at synchronization channel for time interval (IP) selected by cursor.
10.May.2013 12:02:00	Timestamp of interval (IP) selected by cursor.
32m 00s	Current GENERAL RECORDER time (d - days, h - hours, m - minutes, s - seconds)

Table 4.11: Keys in Trend screens

		Selects between the following options:
	U I f U, I U/ I	Shows voltage trend.
	u I f U, I U/ I	Shows current trend.
	u I f U, I U/ I	Shows frequency trend.
	U I f U , I U/ I	Shows voltage and current trend (single mode).
	u I f U, I U / I	Shows voltage and current trend (dual mode).
		Selects between phases, neutral channel, all-phases view:
	1 2 3 N \blacktriangle	Shows trend for phase L1.
	1 2 3 N \blacktriangle	Shows trend for phase L2.
	1 2 3 N \blacktriangle	Shows trend for phase L3.
	1 2 3 N \blacktriangle	Shows trend for neutral channel.
	1 2 3 N \blacktriangle	Shows all phases trends.
	12 23 31 Δ	Shows trend for phases L12.
	12 23 31 Δ	Shows trend for phases L23.
	12 23 31 Δ	Shows trend for phases L31.
12 23 31 Δ	Shows all phase-to-phase trends.	
	METER	Switches to METER view.
	SCOPE	Switches to SCOPE view.
	TREND	Switches to TREND view.
		Moves cursor and selects time interval (IP) for observation.
		Returns to the "MEASUREMENTS" submenu.

4.6 Power

In POWER screens instrument shows measured power parameters. Results can be seen in a tabular (METER) or a graphical form (TREND). TREND view is active only while GENERAL RECORDER is active. See section 4.14 for instructions how to start recorder. In order to fully understand meanings of particular power parameter see sections 6.1.5.

4.6.1 Meter

By entering POWER option from Measurements submenu, the tabular POWER (METER) screen is shown (see figure below). Which measurement is present on display depends on following settings:

- Power measurement method: Modern (IEEE 1459), Classic (Vector) or Classic (Arithmetic)
- Connection type: 1W, 2W, 3W...
- Selected VIEW: Combined, Fundamental or Nonfundamental

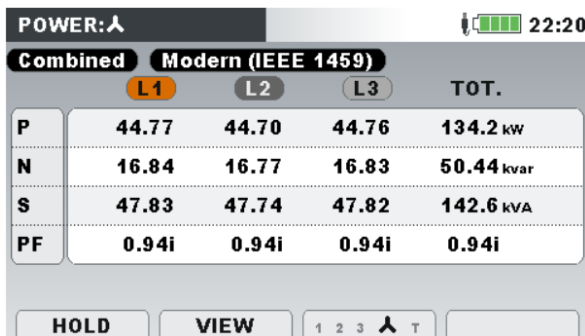

Figure 4.23: Power measurements summary (combined)

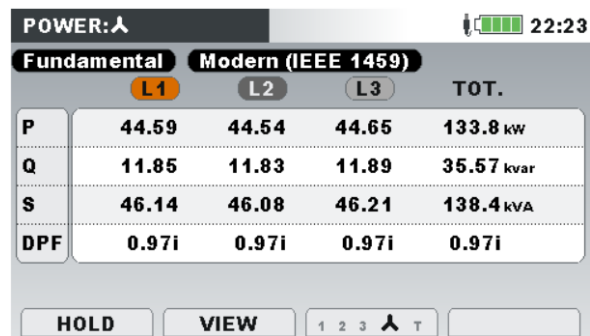

Figure 4.24: Power measurements summary (fundamental)

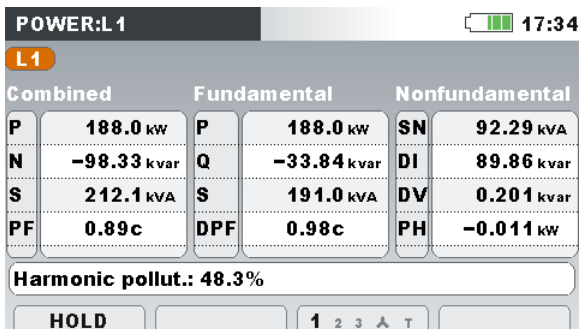

Figure 4.25: Detailed power measurements at phase L1

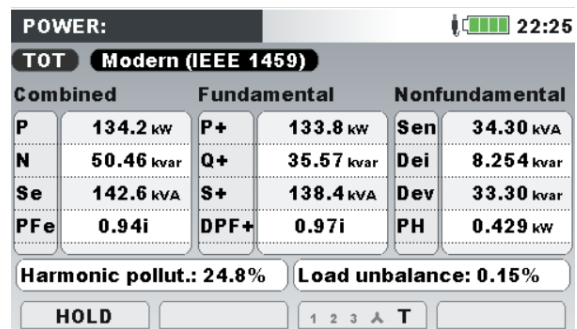

Figure 4.26: Detailed total power measurements

Description of symbols and abbreviations used in POWER (METER) screens are shown in table below.







Table 4.12: Instrument screen symbols and abbreviations (see 6.1.5 for details)

P	Depending on the screen position:
---	-----------------------------------

	In Combined column: Combined (fundamental and nonfundamental) active power ($\pm P_1, \pm P_2, \pm P_3, \pm P_{tot}$) In Fundamental column: Fundamental active phase power ($\pm P_{fund1}, \pm P_{fund2}, \pm P_{fund3}$)
N	Combined (fundamental and nonfundamental) nonactive phase power ($\pm N_1, \pm N_2, \pm N_3$) and nonactive total vector ($\pm N_{tot}$)
Na	Combined (fundamental and nonfundamental) nonactive arithmetic total power ($\pm Na_{tot}$)
Q	Fundamental reactive phase power ($\pm Q_{fund1}, \pm Q_{fund2}, \pm Q_{fund3}$)
Qa	Fundamental total arithmetic reactive power ($Qa_{fund_{tot}}$)
Qv	Fundamental total vector reactive power ($\pm Qv_{fund_{tot}}$)
S	Depending on the screen position: In Combined column: Combined (fundamental and nonfundamental) apparent phase power (S_1, S_2, S_3) In Fundamental column: Fundamental apparent phase power ($S_{fund1}, S_{fund2}, S_{fund3}$)
Sa	Depending on the screen position: In Combined column: Combined (fundamental and nonfundamental) total arithmetic apparent power (Sa_{tot}) In Fundamental column: Fundamental total arithmetic apparent power ($Sa_{fund_{tot}}$)
Sv	Depending on the screen position: In Combined column: Combined (fundamental and nonfundamental) total vector apparent power (Sv_{tot}) In Fundamental column: Fundamental total vector apparent power ($Sv_{fund_{tot}}$)
P+	Positive sequence of total active fundamental power ($\pm P^+_{tot}$)
Q+	Positive sequence of total reactive fundamental power ($\pm Q^+_{tot}$)
S+	Positive sequence of total apparent fundamental power ($\pm S^+_{tot}$)
DPF+	Positive sequence power factor (fundamental, total)
Se	Combined (fundamental and nonfundamental) total effective apparent power (Se_{tot})
SN	Phase nonfundamental apparent power (SN_1, SN_2, SN_3)
Sen	Total effective nonfundamental apparent power (Sen_{tot})
DI	Phase current distortion power (DI_1, DI_2, DI_3)
DeI	Total effective current distortion power (DeI_{tot})
Dv	Phase voltage distortion power (DV_1, DV_2, DV_3)

Dev	Total effective voltage distortion power (Dev_{tot})
PH	Phase and total harmonic active power ($P_{H1}^+, P_{H2}^+, P_{H3}^+, \pm P_{Htot}$)
PF	Phase combined (fundamental and nonfundamental) power factor ($\pm PF_1, \pm PF_2, \pm PF_3$)
PFa	Total arithmetic combined (fundamental and nonfundamental) power factor ($\pm PFa$)
PF _e	Total effective combined (fundamental and nonfundamental) power factor ($\pm PFe$)
PF _v	Total vector combined (fundamental and nonfundamental) power factor ($\pm PFv$).
DPF	Phase fundamental power factor ($\pm DPF_1, \pm DPF_2, \pm DPF_3$) and positive sequence total power factor ($\pm DPF^+$)
DPFa	Total arithmetic fundamental power factor ($\pm DPFa$).
DPF _v	Total vector fundamental power factor ($\pm DPFv$).
Harmonic Pollut.	Harmonic pollution according to the standard IEEE 1459
Load unbalance	Load unbalance according to the standard IEEE 1459

Table 4.13: Keys in Power (METER) screens

	HOLD	Holds measurement on display. Hold clock time will be displayed in the right top corner.
	RUN	Runs held measurement.
	VIEW	Switches between Combined, Fundamental and Nonfundamental view.
	1 2 3 ^ T	Shows measurements for phase L1.
	1 2 3 ^ T	Shows measurements for phase L2.
	1 2 3 ^ T	Shows measurements for phase L3.
	1 2 3 ^ T	Shows brief view on measurements on all phases in a single screen.
	METER	Shows measurement results for TOTAL power measurements.
	TREND	Switches to METER view.
		Switches to TREND view (available only during recording).
		Triggers Waveform snapshot.
		Returns to the "MEASUREMENTS" submenu.

4.6.2 Trend

During active recording TREND view is available (see section 4.14 for instructions how to start GENERAL RECORDER).

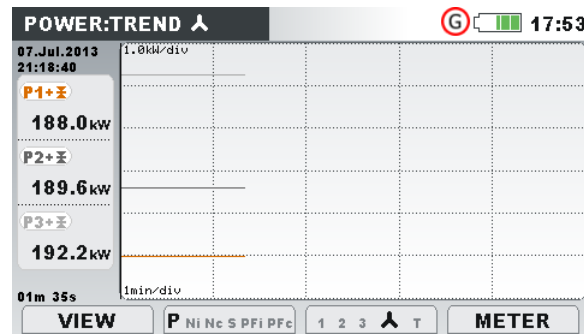



Figure 4.27: Power trend screen

Table 4.14: Instrument screen symbols and abbreviations

P1±, P2±, P3±, Pt±	View: Combined power Maximal (▲), average (⊠) and minimal (▼) value of consumed (P_1^+ , P_2^+ , P_3^+ , P_{tot}^+) or generated (P_1^- , P_2^- , P_3^- , P_{tot}^-) active combined power for time interval (IP) selected by cursor.
P1±, P2±, P3±, P+±	View: Fundamental power Maximal (▲), average (⊠) and minimal (▼) value of consumed ($Pfund_1^+$, $Pfund_2^+$, $Pfund_3^+$, P_{tot}^+) or generated ($Pfund_1^-$, $Pfund_2^-$, $Pfund_3^-$, P_{tot}^-) active fundamental power for time interval (IP) selected by cursor.
Ni1±, Ni2±, Ni3±, Nit±	View: Combined power Maximal (▲), average (⊠) and minimal (▼) value of consumed (N_{1ind}^+ , N_{2ind}^+ , N_{3ind}^+ , N_{totind}^+) or generated (N_{1ind}^- , N_{2ind}^- , N_{3ind}^- , N_{totind}^-) inductive combined nonactive power for time interval (IP) selected by cursor.
Nc1±, Nc2±, Nc3±, Nct±	View: Combined power Maximal (▲), average (⊠) and minimal (▼) value of consumed (N_{1cap}^+ , N_{2cap}^+ , N_{3cap}^+ , N_{totcap}^+) or generated (N_{1cap}^- , N_{2cap}^- , N_{3cap}^- , N_{totcap}^-) capacitive combined nonactive power for time interval (IP) selected by cursor.
S1, S2, S3, Se	View: Combined power Maximal (▲), average (⊠) and minimal (▼) value of combined apparent power (S_1 , S_2 , S_3 , $S_{e_{tot}}$) for time interval (IP) selected by cursor.
S1, S2, S3, S+	View: Fundamental power Maximal (▲), average (⊠) and minimal (▼) value of fundamental apparent power ($Sfund_1$, $Sfund_2$, $Sfund_3$, S_{tot}^+) for time interval (IP) selected by cursor.
PFi1±, PFi2±, PFi3±, PFit±	View: Combined power Maximal (▲), average (⊠) and minimal (▼) value of inductive power factor (1 st quadrant: PF_{1ind}^+ , PF_{2ind}^+ , PF_{3ind}^+ , PF_{totind}^+ and 3 rd quadrant: PF_{1ind}^- , PF_{2ind}^- , PF_{3ind}^- , PF_{totind}^-) for time interval (IP) selected by cursor.
PFc1±, PFc2±, PFc3±, PFct±	View: Combined power Maximal (▲), average (⊠) and minimal (▼) value of capacitive power factor (4 th quadrant: PF_{1cap}^+ , PF_{2cap}^+ , PF_{3cap}^+ , PF_{totcap}^+ and 2 nd quadrant: PF_{1cap}^- , PF_{2cap}^- , PF_{3cap}^- , PF_{totcap}^-) for time interval (IP) selected by cursor.

Qi1±, Qi2±, Qi3±, Q+i±	View: Fundamental power Maximal (⚡), average (⚡) and minimal (⚡) value of consumed (Q_{1ind}^+ , Q_{2ind}^+ , Q_{3ind}^+ , Q_{totind}^+) or generated (Q_{1ind}^- , Q_{2ind}^- , Q_{3ind}^- , Q_{totind}^-) fundamental reactive inductive power for time interval (IP) selected by cursor.
Qc1±, Qc2±, Qc3±, Q+c±	View: Fundamental power Maximal (⚡), average (⚡) and minimal (⚡) value of consumed (Q_{1cap}^+ , Q_{2cap}^+ , Q_{3cap}^+ , Q_{captot}^+) or generated (Q_{1cap}^- , Q_{2cap}^- , Q_{3cap}^- , Q_{captot}^-) fundamental reactive capacitive power for time interval (IP) selected by cursor.
DPFi1±, DPFi2±, DPFi3± DPF+it±	View: Fundamental power Maximal (⚡), average (⚡) and minimal (⚡) value of inductive displacement power factor (1 st quadrant: DPF_{1ind}^+ , DPF_{2ind}^+ , DPF_{3ind}^+ , DPF_{totind}^+ , and 3 rd quadrant: DPF_{1ind}^- , DPF_{2ind}^- , DPF_{3ind}^- , DPF_{totind}^-) for time interval (IP) selected by cursor.
DPFc1±, DPFc2±, DPFc3± DPF+ct±	View: Fundamental power Maximal (⚡), average (⚡) and minimal (⚡) value of capacitive displacement power factor (4 th quadrant: DPF_{1cap}^+ , DPF_{2cap}^+ , DPF_{3cap}^+ , DPF_{totcap}^+ , and 2 nd quadrant: DPF_{1cap}^- , DPF_{2cap}^- , DPF_{3cap}^- , DPF_{totcap}^-) for time interval (IP) selected by cursor.
Sn1, Sn2, Sn3, Sen	View: Nonfundamental power Maximal (⚡), average (⚡) and minimal (⚡) value of consumed or generated nonfundamental apparent power (SN_1 , SN_2 , SN_3 , Sen_{tot}) for time interval (IP) selected by cursor.
Di1, Di2, Di3, Dei	View: Nonfundamental power Maximal (⚡), average (⚡) and minimal (⚡) value of consumed or generated phase current distortion power (DI_1 , DI_2 , DI_3 , Dei_{tot}) for time interval (IP) selected by cursor.
Dv1, Dv2, Dv3, Dev	View: Nonfundamental power Maximal (⚡), average (⚡) and minimal (⚡) value of consumed or generated phase voltage distortion power (DV_1 , DV_2 , DV_3 , Dev_{tot}) for time interval (IP) selected by cursor.
Ph1±, Ph2±, Ph3±, Pht±	View: Nonfundamental power Maximal (⚡), average (⚡) and minimal (⚡) value of consumed (P_{H1}^+ , P_{H2}^+ , P_{H3}^+ , P_{Htot}^+) or generated (P_{H1}^- , P_{H2}^- , P_{H3}^- , P_{Htot}^-) active harmonic power for time interval (IP) selected by cursor.

Table 4.15: Keys in Power (TREND) screens

	Selects which measurement should instrument represent on graph:
	<ul style="list-style-type: none"> Consumed or Generated Measurements related to consumed (suffix: +) or generated power (suffix: -).
	<ul style="list-style-type: none"> Combined, Fundamental or Nonfundamental

Measurement related to fundamental power, nonfundamental power or combined.

Keys in VIEW window:

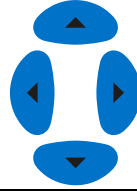

Selects option.



Confirms selected option.



Exits selection window without change.

If Combined power is selected:

P Ni Nc S PFi Pfc

Shows combined active power trend.

P **Ni** Nc S PFi Pfc

Shows combined inductive nonactive power trend.

P Ni **Nc** S PFi Pfc

Shows combined capacitive nonactive power trend.

P Ni Nc **S** PFi Pfc

Shows combined apparent power trend.

P Ni Nc S **PFi** Pfc

Shows inductive power factor trend.

P Ni Nc S Pfi **PFC**

Shows capacitive power factor trend.

If Fundamental power is selected:

F2

P Qi Qc S DPFI DPfc

Shows fundamental active power trend.

P **Qi** Qc S DPFI DPfc

Shows fundamental inductive reactive power trend.

P Qi **Qc** S DPFI DPfc

Shows fundamental capacitive reactive power trend.

P Qi Qc **S** DPFI DPfc

Shows fundamental apparent power trend.

P Qi Qc S **DPFI** DPfc

Shows inductive displacement power factor trend.

P Qi Qc S DPfi **DPFC**

Shows capacitive displacement power factor trend.

If Nonfundamental power is selected:

Sn Di Dv Ph

Shows nonfundamental apparent power trend.

Sn **Di** Dv Ph

Shows nonfundamental current distortion power.

Sn Di **DV** Ph

Shows nonfundamental voltage distortion power.

Sn Di Dv **Ph**

Shows nonfundamental active power.

Selects between phase, all-phases and Total power view:

F3

1 2 3 ^ T

Shows power parameters for phase L1.

1 **2** 3 ^ T

Shows power parameters for phase L2.

1 2 **3** ^ T



Shows power parameters for phase L3.

1 2 3 ^ **T**

Shows power parameters for phases L1, L2 and L3 on the same graph.

1 2 3 ^ **T**

Shows Total power parameters.

	METER	Switches to METER view.
	TREND	Switches to TREND view (available only during recording).
		Moves cursor and selects time interval (IP) for observation.
		Returns to the "MEASUREMENTS" submenu.

4.7 Energy

4.7.1 Meter

Instrument shows status of energy counters in energy menu. Results can be seen in a tabular (METER) form. The meter screens are shown on figures below.

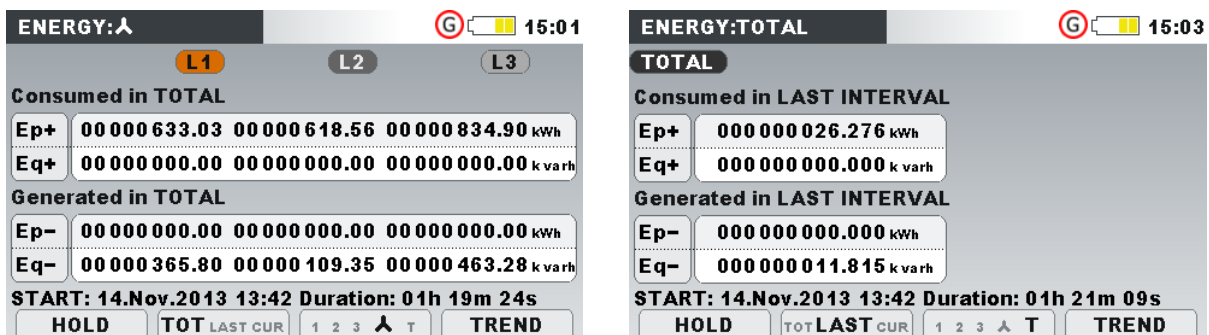

Figure 4.28: Energy counters screen (General Recorder is running)

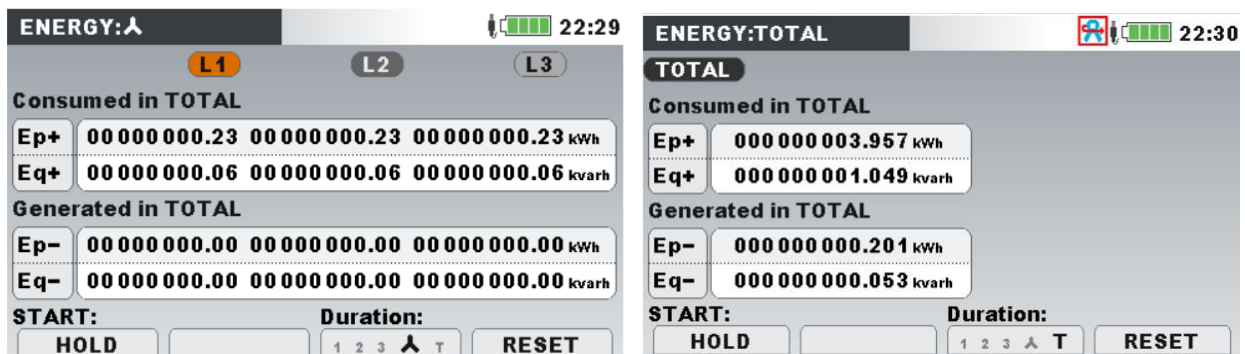



Figure 4.29: Energy counters screen (General Recorder is not running)

Table 4.16: Instrument screen symbols and abbreviations

Ep+	Consumed (+) phase (Ep ₁ ⁺ , Ep ₂ ⁺ , Ep ₃ ⁺) or total (Ep _{tot} ⁺) active energy
Ep-	Generated (-) phase (Ep ₁ ⁻ , Ep ₂ ⁻ , Ep ₃ ⁻) or total (Ep _{tot} ⁻) active energy
Eq+	Consumed (+) phase (Eq ₁ ⁺ , Eq ₂ ⁺ , Eq ₃ ⁺) or total (Eq _{tot} ⁺) fundamental reactive energy
Eq-	Generated (-) phase (Eq ₁ ⁻ , Eq ₂ ⁻ , Eq ₃ ⁻) or total (Eq _{tot} ⁻) fundamental reactive energy

Start	Recorder start time and date
Duration	Recorder elapsed time

Table 4.17: Keys in Energy (METER) screens

F1	HOLD	Holds measurement on display.
	RUN	Runs held measurement.
F2	TOT LAST CUR	Shows energy registers for whole record.
	TOT LAST CUR	Shows energy registers for last interval.
	TOT LAST CUR	Shows energy registers for current interval.
F3	1 2 3 ^ T	Shows energy parameters for phase L1.
	1 2 3 ^ T	Shows energy parameters for phase L2.
	1 2 3 ^ T	Shows energy parameters for phase L3.
	1 2 3 ^ T	Shows all phases energy.
	1 2 3 ^ T	Shows energy parameters for Totals.
F4	METER	Switches to METER view.
	TREND	Switches to TREND view.
	EFF	Switches to EFFICIENCY view.
	RESET	Reset energy counters
		Triggers Waveform snapshot.
ESC		Returns to the "MEASUREMENTS" submenu.

4.7.2 Trend

TREND view is available only during active recording (see section 4.14 for instructions how to start GENERAL RECORDER).

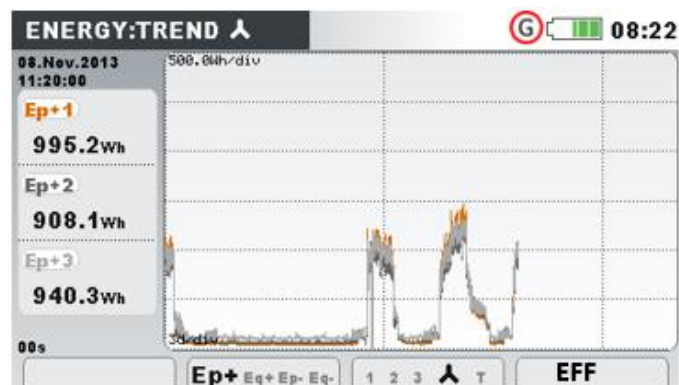

Figure 4.30: Energy trend screen

Table 4.18: Instrument screen symbols and abbreviations

Ep+	Consumed (+) phase (Ep ₁ ⁺ , Ep ₂ ⁺ , Ep ₃ ⁺) or total (Ep _{tot} ⁺) active energy
-----	---

Ep-	Generated (-) phase (Ep ₁ ⁻ , Ep ₂ ⁻ , Ep ₃ ⁻) or total (Ep _{tot} ⁻) active energy
Eq+	Consumed (+) phase (Eq ₁ ⁺ , Eq ₂ ⁺ , Eq ₃ ⁺) or total (Eq _{tot} ⁺) fundamental reactive energy
Eq-	Generated (-) phase (Eq ₁ ⁻ , Eq ₂ ⁻ , Eq ₃ ⁻) or total (Eq _{tot} ⁻) fundamental reactive energy
EFF	Efficiency presentation

Table 4.19: Keys in Energy (TREND) screens

F2	Ep+ Eq+ Ep- Eq-	Shows active consumed energy for time interval (IP) selected by cursor.
	Ep+ Eq+ Ep- Eq-	Shows reactive consumed energy for time interval (IP) selected by cursor.
	Ep+ Eq+ Ep- Eq-	Shows active generated energy for time interval (IP) selected by cursor.
	Ep+ Eq+ Ep- Eq-	Shows reactive generated energy for time interval (IP) selected by cursor.
F3	1 2 3 ^ T	Shows energy records for phase L1.
	1 2 3 ^ T	Shows energy records for phase L2.
	1 2 3 ^ T	Shows energy records for phase L3.
	1 2 3 ^ T	Shows all phases energy records.
	1 2 3 ^ T	Shows energy records for Totals.
F4	METER	Switches to METER view.
	TREND	Switches to TREND view.
	EFF	Switches to EFFICIENCY view.
ESC		Returns to the "MEASUREMENTS" submenu.

4.7.3 Efficiency

EFFICIENCY view is available only during active recording (see section 4.14 for instructions how to start GENERAL RECORDER).

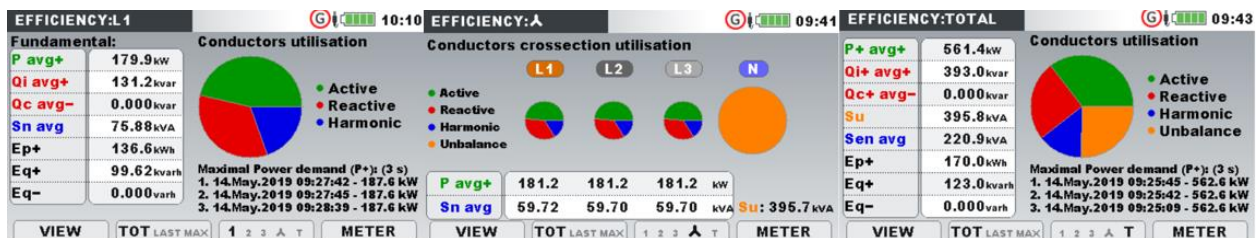

Figure 4.31: Energy efficiency screen

Table 4.20: Instrument screen symbols and abbreviations

P avg+	Consumed phase fundamental active power (Pfund ₁ ⁺ , Pfund ₂ ⁺ , Pfund ₃ ⁺)
P+ avg+	Positive sequence of total fundamental consumed active power (P ⁺ _{tot} ⁺)

P avg-	Generated phase fundamental active power ($Pfund_1^-, Pfund_2^-, Pfund_3^-$)
P+ avg-	Positive sequence of total fundamental generated active power (P_{tot}^+) Shown active power is averaged over chosen time interval (key: F2) <ul style="list-style-type: none"> TOT – shows total average (for complete record) active power LAST – shows average active power in the last interval MAX - shows average active power in interval where Ep was maximal.
Qi avg+	Consumed phase fundamental inductive reactive power ($Qfund_{ind1}^+, Qfund_{ind2}^+, Qfund_{ind3}^+$)
Qi+ avg+	Positive sequence of total inductive fundamental consumed reactive power (Q_{tot}^+)
Qi avg-	Generated phase fundamental inductive reactive power ($Qfund_{ind1}^-, Qfund_{ind2}^-, Qfund_{ind3}^-$)
Qi+ avg-	Positive sequence of total inductive fundamental generated reactive power (Q_{tot}^-) Shown fundamental inductive reactive power is averaged over chosen time interval (key: F2) <ul style="list-style-type: none"> TOT – shows total average (for complete record) fundamental inductive reactive power LAST – shows average fundamental inductive reactive power in the last interval MAX – shows average fundamental inductive reactive power in interval where Ep was maximal.
Qc avg+	Consumed phase fundamental capacitive reactive power ($Qfund_{cap1}^+, Qfund_{cap2}^+, Qfund_{cap3}^+$)
Qc+ avg+	Positive sequence of total capacitive fundamental consumed reactive power (Q_{tot}^+)
Qc avg-	Generated phase fundamental capacitive reactive power ($Qfund_{cap1}^-, Qfund_{cap2}^-, Qfund_{cap3}^-$)
Qc+ avg-	Positive sequence of total capacitive fundamental generated reactive power (Q_{tot}^-) Shown fundamental capacitive reactive power is averaged over chosen time interval (key: F2) <ul style="list-style-type: none"> TOT – shows total average (for complete record) fundamental capacitive reactive power LAST – shows average fundamental capacitive reactive power in the last interval MAX – shows average fundamental capacitive reactive power in interval where Ep was maximal.
Sn avg	Phase nonfundamental apparent power (SN_1, SN_2, SN_3)
Sen avg	Total effective nonfundamental apparent power (Sen). Shown nonfundamental apparent power is averaged over chosen time interval (key: F2) <ul style="list-style-type: none"> TOT – shows total average (for complete record) of nonfundamental apparent power LAST – shows average nonfundamental apparent power in the last interval

	<ul style="list-style-type: none"> • MAX – shows average nonfundamental apparent power in interval where E_p was maximal.
Su	Fundamental unbalanced power, according to the IEEE 1459-2010
Ep+	Consumed phase (Ep_1^+, Ep_2^+, Ep_3^+) or total (Ep_{tot}^+) active energy
Ep-	Generated phase (Ep_1^-, Ep_2^-, Ep_3^-) or total (Ep_{tot}^-) active energy
	Shown active energy depends on chosen time interval (key: F2) <ul style="list-style-type: none"> • TOT – shows accumulated energy for complete record • LAST – shows accumulated energy in last interval • MAX – shows maximal accumulated energy in any interval
Eq+	Consumed (+) phase (Eq_1^+, Eq_2^+, Eq_3^+) or total (Eq_{tot}^+) fundamental reactive energy
Eq-	Generated (-) phase (Eq_1^-, Eq_2^-, Eq_3^-) or total (Eq_{tot}^-) fundamental reactive energy
	Shown reactive energy depends on chosen time interval (key: F2) <ul style="list-style-type: none"> • TOT – shows accumulated energy for complete record • LAST – shows accumulated energy in last interval • MAX – shows accumulated reactive energy in interval where E_p was maximal.
Conductors utilisation	Shows conductor cross section utilisation for chosen time interval (TOT/LAST/MAX): <ul style="list-style-type: none"> • GREEN colour – represents part of conductor cross section (wire) used for active energy transfer (E_p) • RED colour – represents part of conductor cross section (wire) used for fundamental reactive energy transfer (Eq) • BLUE colour – represents part of conductor cross section (wire) used for nonfundamental (harmonic) apparent energy transfer (S_N) • BROWN colour – represents unbalanced power (S_U) portion flowing in polyphase system in respect to phase power flow.
	
Date	End time of shown interval.
Max. Power Demand	Shows three intervals where measured active power was maximal.

Table 4.21: Keys in Energy (TREND) screens

F1	VIEW	Switches between Consumed (+) and Generated (-) energy view.
F2	TOT LAST MAX	Shows parameters for complete record duration
	TOT LAST MAX	Shows parameters for last (complete) recorded interval
	TOT LAST MAX	Shows parameters for interval, where active energy was maximal
F3	1 2 3 ^ T	Shows energy records for phase L1.
	1 2 3 ^ T	Shows energy records for phase L2.
	1 2 3 ^ T	Shows energy records for phase L3.
	1 2 3 ^ T	Shows all phases energy records.
	1 2 3 ^ T	Shows energy records for Totals.
	METER	Switches to METER view.

TREND	Switches to TREND view.
F4 EFF	Switches to EFFICIENCY view.
ESC	Returns to the "MEASUREMENTS" submenu.

4.8 Harmonics / interharmonics

Harmonics presents voltage and current signals as a sum of sinusoids of power frequency and its integer multiples. Sinusoidal wave with frequency k-times higher than fundamental (k is an integer) is called harmonic wave and is denoted with amplitude and a phase shift (phase angle) to a fundamental frequency signal. If a signal decomposition with Fourier transformation results with presence of a frequency that is not integer multiple of fundamental, this frequency is called interharmonic frequency and component with such frequency is called interharmonic. See 6.1.8 for details.

4.8.1 Meter

By entering HARMONICS option from Measurements submenu, the tabular HARMONICS (METER) screen is shown (see figure below). In this screen's voltage and current harmonics or interharmonics and THD are shown.

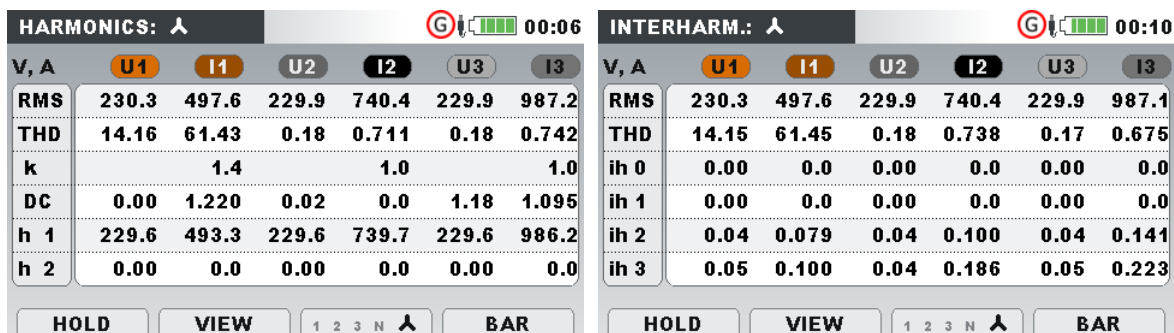

Figure 4.32: Harmonics and interharmonics (METER) screens

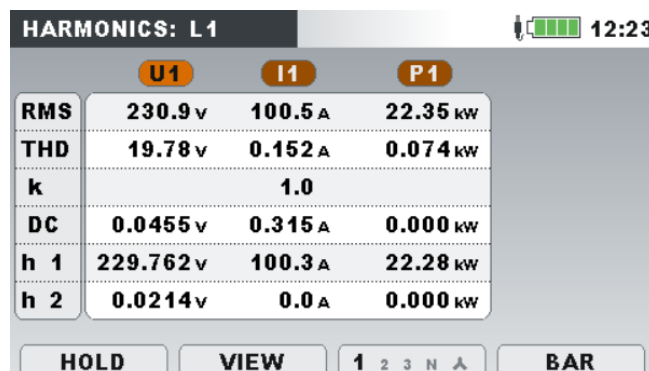



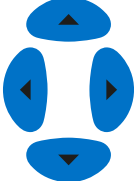



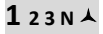
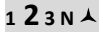
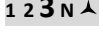

Figure 4.33: Harmonics and Power harmonics (METER) screens



Description of symbols and abbreviations used in METER screens are shown in table below.

Table 4.22: Instrument screen symbols and abbreviations

RMS	RMS voltage / current value
THD	Total voltage / current harmonic distortion THD_U and THD_I in % of fundamental voltage / current harmonic or in RMS V, A.
k	k-factor (unit-less) indicates the amount of harmonics that load generate
DC	Voltage or current DC component in % of fundamental voltage / current harmonic or in RMS V, A.
h1 ... h50	n-th harmonic voltage U_{h_n} or current I_{h_n} component in % of fundamental voltage / current harmonic or in RMS V, A.
ih0 ... ih50	n-th interharmonic voltage U_{ih_n} or current I_{ih_n} component in % of fundamental voltage / current harmonic or in RMS V, A.

Table 4.23: Keys in Harmonics / interharmonics (METER) screens

	HOLD	Holds measurement on display. Hold clock time will be displayed in the right top corner.	
	RUN	Runs held measurement.	
Switches view between Harmonics and Interharmonics. Switches units between:			
<ul style="list-style-type: none"> • RMS (Volts, Amperes) • % of fundamental harmonic 			
	VIEW	Keys in VIEW window:	
			Selects option.
			Confirms selected option.
			Exits selection window without change.
Selects between single phase, neutral, all-phases and line harmonics / interharmonics view.			
		Shows harmonics/interharmonics/power harmonics components for phase L1.	
		Shows harmonics/interharmonics/power harmonics components for phase L2.	
		Shows harmonics/interharmonics/power harmonics components for phase L3.	
		Shows harmonics / interharmonics components for neutral channel.	
		Shows harmonics / interharmonics components for all phases on single screen.	

12 23 31 Δ	Shows harmonics / interharmonics components for phase L12.
12 23 31 Δ	Shows harmonics / interharmonics components for phase L23.
12 23 31 Δ	Shows harmonics / interharmonics components for phase L31.
12 23 31 Δ	Shows harmonics / interharmonics components for phase-to-phase voltages.
METER	Switches to METER view.
BAR	Switches to BAR view.
F4 AVG	Switches to AVG (average) view (available only during recording).
TREND	Switches to TREND view (available only during recording).
	Shifts through harmonic / interharmonic components.
	Triggers Waveform snapshot.
ESC	Returns to the "MEASUREMENTS" submenu.

4.8.2 Histogram (Bar)

Bar screen displays dual bar graphs. The upper bar graph shows instantaneous voltage harmonics and the lower bar graph shows instantaneous current harmonics.

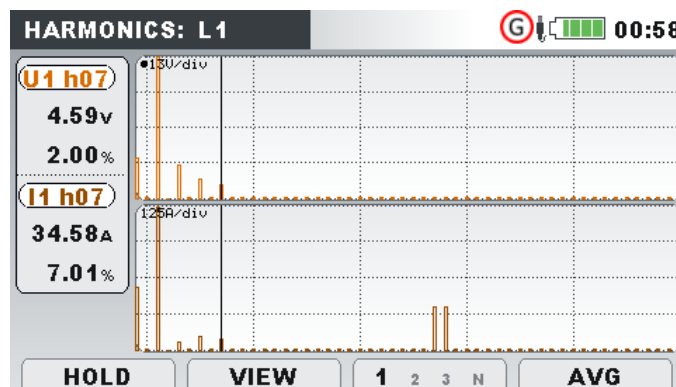

Figure 4.34: Harmonics histogram screen











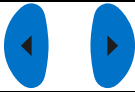

Description of symbols and abbreviations used in BAR screens are shown in table below.

Table 4.24: Instrument screen symbols and abbreviations

Ux h01 ... h50	Instantaneous voltage harmonic / interharmonic component in V_{RMS} and in % of fundamental voltage
Ix h01 ... h50	Instantaneous current harmonic / interharmonic component in A_{RMS} and in % of fundamental current
Ux DC	Instantaneous DC voltage in V and in % of fundamental voltage
Ix DC	Instantaneous DC current in A and in % of fundamental current

Ux THD	Instantaneous total voltage harmonic distortion THD_U in V and in % of fundamental voltage
Ix THD	Instantaneous total current harmonic distortion THD_I in A_{RMS} and in % of fundamental current

Table 4.25: Keys in Harmonics / interharmonics (BAR) screens

	HOLD	Holds measurement on display.
	RUN	Runs held measurement.
Switches view between harmonics and interharmonics.		
Keys in VIEW window:		
	VIEW	 Selects option.
		 Confirms selected option.
		 Exits selection window without change.
		Selects between single phases and neutral channel harmonics / interharmonics bars.
	1 2 3 N	Shows harmonics / interharmonics components for phase L1.
	1 2 3 N	Shows harmonics / interharmonics components for phase L2.
	1 2 3 N	Shows harmonics / interharmonics components for phase L3.
	1 2 3 N	Shows harmonics / interharmonics components for neutral channel.
	12 23 31	Shows harmonics / interharmonics components for phase L12.
	12 23 31	Shows harmonics / interharmonics components for phases L23.
	12 23 31	Shows harmonics / interharmonics components for phases L31.
	METER	Switches to METER view.
	BAR	Switches to BAR view.
	AVG	Switches to AVG (average) view (available only during recording).
	TREND	Switches to TREND view (available only during recording).
	Scales displayed histogram by amplitude.	
	Scrolls cursor to select single harmonic / interharmonic bar.	
	Toggles cursor between voltage and current histogram.	
	Triggers Waveform snapshot.	
	Returns to the "MEASUREMENTS" submenu.	

4.8.3 Harmonics Average Histogram (Avg Bar)

During active GENERAL RECORDER, Harmonics average histogram AVG view is available (see section 4.14 for instructions how to start GENERAL RECORDER). In this view average voltage and current harmonic values are shown (averaged from beginning of the recording to the current moment). Harmonics average histogram screen displays dual bar graphs. The upper bar graph shows average voltage harmonics and the lower bar graph shows average current harmonics.

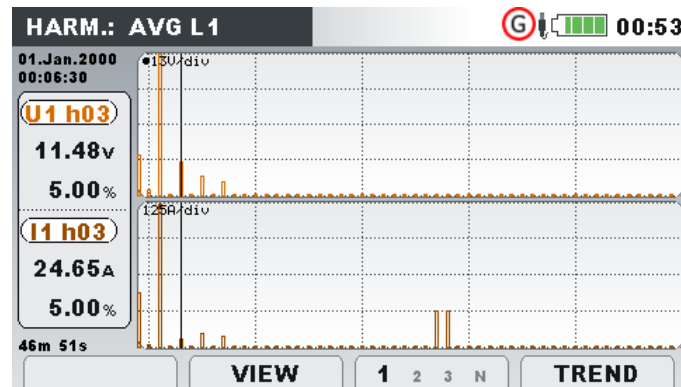

Figure 4.35: Harmonics average histogram screen

Description of symbols and abbreviations used in AVG screens are shown in table below.

Table 4.26: Instrument screen symbols and abbreviations

Ux h01 ... h50	Average voltage harmonic / interharmonic component in V_{RMS} and in % of fundamental voltage (from beginning of the recording)
Ix h01 ... h50	Average current harmonic / interharmonic component in A_{RMS} and in % of fundamental current
Ux DC	Average DC voltage in V and in % of fundamental voltage
Ix DC	Average DC current in A and in % of fundamental current
Ux THD	Average total voltage harmonic distortion THD_U in V and in % of fundamental voltage
Ix THD	Average total current harmonic distortion THD_I in A_{RMS} and in % of fundamental current

Table 4.27: Keys in Harmonics / interharmonics (AVG) screens

Switches view between harmonics and interharmonics.

Keys in VIEW window:

F2 **VIEW**

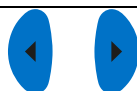





Selects option.



Confirms selected option.



Exits selection window without change.

		Selects between single phases and neutral channel harmonics / interharmonics bars.
F3	1 2 3 N	Shows harmonics / interharmonics components for phase L1.
	1 2 3 N	Shows harmonics / interharmonics components for phase L2.
	1 2 3 N	Shows harmonics / interharmonics components for phase L3.
	1 2 3 N	Shows harmonics / interharmonics components for neutral channel.
	12 23 31	Shows harmonics / interharmonics components for phase L12.
	12 23 31	Shows harmonics / interharmonics components for phases L23.
	12 23 31	Shows harmonics / interharmonics components for phases L31.
F4	METER	Switches to METER view.
	BAR	Switches to BAR view.
	AVG	Switches to AVG (average) view (available only during recording).
	TREND	Switches to TREND view (available only during recording).
		Scales displayed histogram by amplitude.
		Scrolls cursor to select single harmonic / interharmonic bar.
		Toggles cursor between voltage and current histogram.
		Triggers Waveform snapshot.
		Returns to the "MEASUREMENTS" submenu.

4.8.4 Trend

During active GENERAL RECORDER, TREND view is available (see section 4.14 for instructions how to start GENERAL RECORDER). Voltage and current harmonic / interharmonic components can be observed by cycling function key F4 (METER-BAR-AVG-TREND).

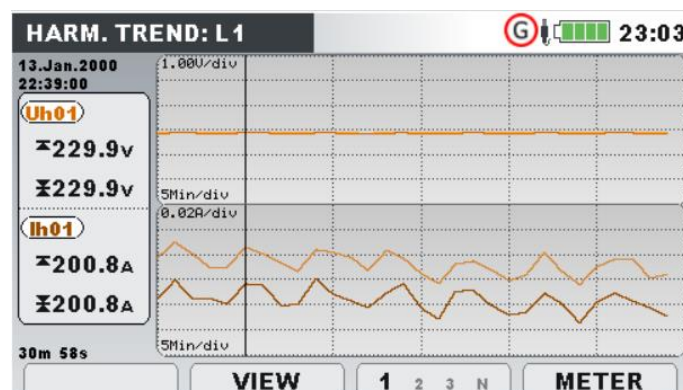

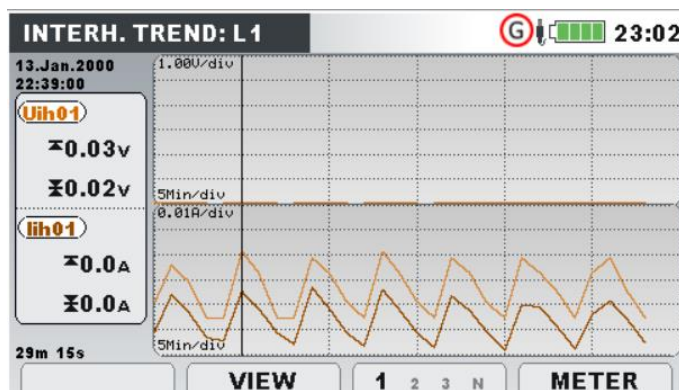

Figure 4.36: Harmonics and interharmonics trend screen

Table 4.28: Instrument screen symbols and abbreviations

ThdU	Interval maximal (▲) and average (⚡) value of total voltage harmonic distortion THD _U for selected phase
ThdI	Interval maximal (▲) and average (⚡) value of total current harmonic distortion THD _I for selected phase
Udc	Interval maximal (▲) and average (⚡) value of DC voltage component for selected phase
Idc	Interval maximal (▲) and average (⚡) value of selected DC current component for selected phase
Uh01...Uh50 Uih01...Uih50	Interval maximal (▲) and average (⚡) value for selected n-th voltage harmonic / interharmonic component for selected phase
Ih01...Ih50 Iih01...Iih50	Interval maximal (▲) and average (⚡) value of selected n-th current harmonic / interharmonic component for selected phase

Table 4.29: Keys in Harmonics / interharmonics (TREND) screens

- Switches between harmonics or interharmonics view.
- Switches measurement units between RMS V, A or % of fundamental harmonic.
- Selects harmonic number for observing.

Keys in VIEW window:

F2

VIEW

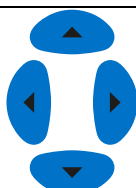





Selects option.

ENTER

Confirms selected option.

ESC

Exits selection window without change.

		Selects between single phases and neutral channel harmonics / interharmonics trends.
	1 2 3 N	Shows selected harmonics / interharmonics components for phase L1.
	1 2 3 N	Shows selected harmonics / interharmonics components for phase L2.
	1 2 3 N	Shows selected harmonics / interharmonics components for phase L3.
	1 2 3 N	Shows selected harmonics / interharmonics components for neutral channel.
	12 23 31	Shows selected harmonics / interharmonics components for phase-to-phase voltage L12.
	12 23 31	Shows selected harmonics / interharmonics components for phase-to-phase voltage L23.
	12 23 31	Shows selected harmonics / interharmonics components for phase-to-phase voltage L31.
<hr/>		
	METER	Switches to METER view.
	BAR	Switches to BAR view.
	AVG	Switches to AVG (average) view (available only during recording).
	TREND	Switches to TREND view (available only during recording).
<hr/>		
		Moves cursor and select time interval (IP) for observation.
<hr/>		
		Returns to the "MEASUREMENTS" submenu.
<hr/>		

4.9 Flickers

Flickers measure the human perception of the effect of amplitude modulation on the mains voltage powering a light bulb. In Flickers menu instrument shows measured flicker parameters. Results can be seen in a tabular (METER) or a graphical form (TREND) - which is active only while GENERAL RECORDER is active. See section 4.14 for instructions how to start recording. In order to understand meanings of particular parameter see section 6.1.9.

4.9.1 Meter

By entering FLICKERS option from MEASUREMENTS submenu, the FLICKERS tabular screen is shown (*see figure below*).

	L1	L2	L3
Urms	229.0	230.5	230.5 v
Pinst,max	1.04	0.34	0.94
Pst(1min)	1.02	0.54	0.97
Pst	1.07	0.25	0.90
Plt	0.78	1.21	0.60

Figure 4.37: Flickers table screen

Description of symbols and abbreviations used in METER screen is shown in table below. Note that Flickers measurement intervals are synchronised to real time clock, and therefore refreshed on minute, 10 minutes and 2 hours intervals.

Table 4.30: Instrument screen symbols and abbreviations

Urms	True effective value $U_1, U_2, U_3, U_{12}, U_{23}, U_{31}$
Pinst,max	Maximal instantaneous flicker for each phase refreshed each 10 seconds
Pst(1min)	Short term (1 min) flicker P_{st1min} for each phase measured in last minute
Pst	Short term (10 min) flicker P_{st} for each phase measured in last 10 minutes
Plt	Long term flicker (2h) P_{st} for each phase measured in last 2 hours

Table 4.31: Keys in Flickers (METER) screen

	HOLD	Holds measurement on display. Hold clock time will be displayed in the right top corner.
	RUN	Runs held measurement.
	METER	Switches to METER view.
	TREND	Switches to TREND view (available only during recording).
		Triggers Waveform snapshot.
		Returns to the "MEASUREMENTS" submenu.

4.9.2 Trend

During active recording TREND view is available (see section 4.14 for instructions how to start recording). Flicker parameters can be observed by cycling function key F4 (METER -TREND). Note that Flicker meter recording intervals are determinate by standard IEC 61000-4-15. Flicker meter therefore works independently from chosen recording interval in GENERAL RECORDER.

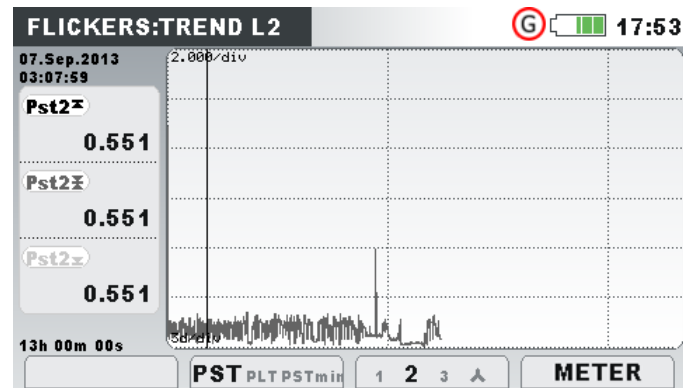









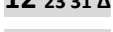

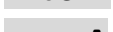







Figure 4.38: Flickers trend screen

Table 4.32: Instrument screen symbols and abbreviations

Pst1m1, Pst1m2, Pst1m3, Pst1m12, Pst1m23, Pst1m31	Maximal (▣), average (⊠) and minimal (▤) value of 1-minute short term flicker $P_{st(1min)}$ for phase voltages U_1, U_2, U_3 or line voltages U_{12}, U_{23}, U_{31}
Pst1, Pst2, Pst3, Pst12, Pst23, Pst31	Maximal (▣), average (⊠) and minimal (▤) value of 10-minutes short term flicker P_{st} for phase voltages U_1, U_2, U_3 or line voltages U_{12}, U_{23}, U_{31}
Plt1, Plt2, Plt3, Plt12, Plt23, Plt31	Maximal (▣), average (⊠) and minimal (▤) value of 2-hours long term flicker P_{lt} in phase voltages U_1, U_2, U_3 or line voltages U_{12}, U_{23}, U_{31}

Table 4.33: Keys in Flickers (TREND) screens

		Selects between the following options: Shows 10 min short term flicker P _{st} .
		Shows long term flicker P _{lt} .
		Shows 1 min short term flicker P _{st1min} .
		Selects between trending various parameters: Shows selected flicker trends for phase L1.
		Shows selected flicker trends for phase L2.
		Shows selected flicker trends for phase L3.
		Shows selected flicker trends for all phases (average only).
		Shows selected flicker trends for phases L12.
		Shows selected flicker trends for phases L23.
		Shows selected flicker trends for phases L31.
		Shows selected flicker trends for all phases (average only).
		Switches to METER view.
		Switches to TREND view (available only during recording).
	Moves cursor and selects time interval (IP) for observation.	
	Returns to the "MEASUREMENTS" submenu.	

4.10 Phase Diagram

Phase diagram graphically represent fundamental voltages, currents and phase angles of the network. This view is strongly recommended for checking instrument connection before measurement. Note that most measurement issues arise from wrongly connected instrument (see 5.1 for recommended measuring practice). On phase diagram screens instrument shows:

- Graphical presentation of voltage and current phase vectors of the measured system,
- Unbalance of the measured system.

4.10.1 Phase diagram

By entering PHASE DIAGRAM option from MEASUREMENTS submenu, the following screen is shown (see figure below).

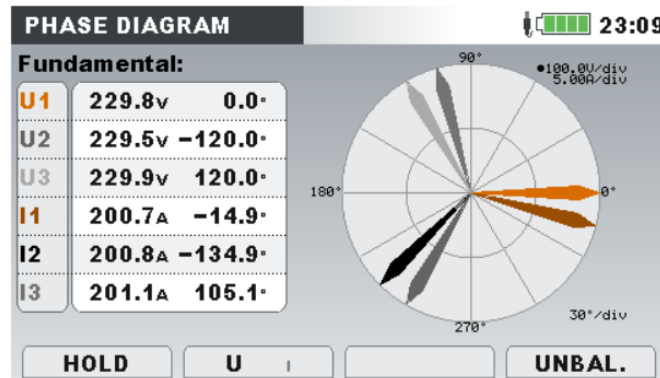





Figure 4.39: Phase diagram screen

Table 4.34: Instrument screen symbols and abbreviations

U1, U2, U3	Fundamental voltages U_{fund1} , U_{fund2} , U_{fund3} with relative phase angle to U_{fund1}
U12, U23, U31	Fundamental voltages U_{fund12} , U_{fund23} , U_{fund31} with relative phase angle to U_{fund12}
I1, I2, I3	Fundamental currents I_{fund1} , I_{fund2} , I_{fund3} with relative phase angle to U_{fund1} or U_{fund12}

Table 4.35: Keys in Phase diagram screen

F1	HOLD	Holds measurement on display. Hold clock time will be displayed in the right top corner.
	RUN	Runs held measurement.
F2	U I	Selects voltage for scaling (with cursors).
	I U	Selects current for scaling (with cursors).
	METER	Switches to PHASE DIAGRAM view.
F4	UNBAL.	Switches to UNBALANCE DIAGRAM view.
	TREND	Switches to TREND view (available only during recording).
		Scales voltage or current phasors.
		Triggers Waveform snapshot.
		Returns to the "MEASUREMENTS" submenu.

4.10.2 Unbalance diagram

Unbalance diagram represents current and voltage unbalance of the measuring system. Unbalance arises when RMS values or phase angles between consecutive phases are not equal. Diagram is shown on figure below.

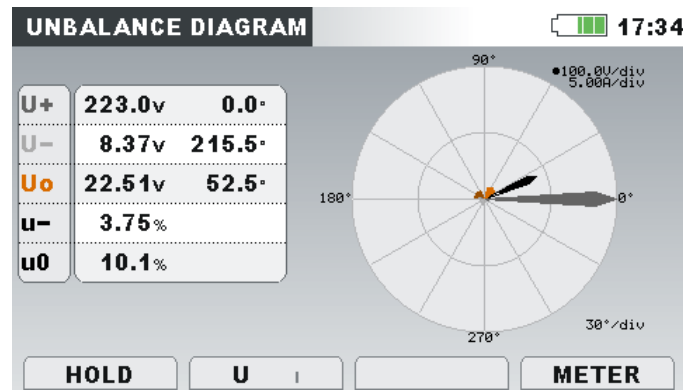

Figure 4.40: Unbalance diagram screen

Table 4.36: Instrument screen symbols and abbreviations

U0	Zero sequence voltage component U^0
I0	Zero sequence current component I^0
U+	Positive sequence voltage component U^+
I+	Positive sequence current component I^+
U-	Negative sequence voltage component U^-
I-	Negative sequence current component I^-
u-	Negative sequence voltage ratio u^-
i-	Negative sequence current ratio i^-
u0	Zero sequence voltage ratio u^0
i0	Zero sequence current ratio i^0

Table 4.37: Keys in Unbalance diagram screens

F1	HOLD	Holds measurement on display. Hold clock time will be displayed in the right top corner.
	RUN	Runs held measurement.
F2	U I	Shows voltage unbalance measurement and selects voltage for scaling (with cursors)
	I U	Shows current unbalance measurement and selects current for scaling (with cursors)
	METER	Switches to PHASE DIAGRAM view.
F4	UNBAL.	Switches to UNBALANCE DIAGRAM view.
	TREND	Switches to TREND view (available only during recording).
		Scales voltage or current phasors.
		Triggers Waveform snapshot.
ESC		Returns to the "MEASUREMENTS" submenu.

4.10.3 Unbalance trend

During active recording UNBALANCE TREND view is available (see section 4.14 for instructions how to start GENERAL RECORDER).

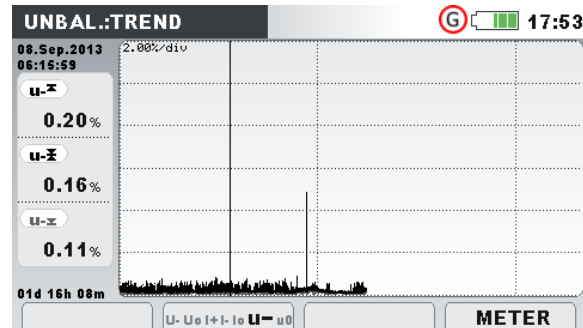

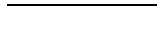
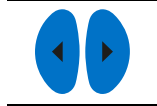

Figure 4.41: Symmetry trend screen

Table 4.38: Instrument screen symbols and abbreviations

u-	Maximal (⚡), average (⚡) and minimal (⚡) value of negative sequence voltage ratio u-
u0	Maximal (⚡), average (⚡) and minimal (⚡) value of zero sequence voltage ratio u ⁰
i-	Maximal (⚡), average (⚡) and minimal (⚡) value of negative sequence current ratio i-
i0	Maximal (⚡), average (⚡) and minimal (⚡) value of zero sequence current ratio i ⁰
U+	Maximal (⚡), average (⚡) and minimal (⚡) value of positive sequence voltage U ⁺
U-	Maximal (⚡), average (⚡) and minimal (⚡) value of negative sequence voltage U ⁻
U0	Maximal (⚡), average (⚡) and minimal (⚡) value of zero sequence voltage U ⁰
I+	Maximal (⚡), average (⚡) and minimal (⚡) value of positive sequence current I ⁺
I-	Maximal (⚡), average (⚡) and minimal (⚡) value of negative sequence current I ⁻
I0	Maximal (⚡), average (⚡) and minimal (⚡) value of zero sequence current I ⁰

Table 4.39: Keys in Unbalance trend screens

F2	U+ U- U0 I+ I- I0 u+ u0 i+ i0	Shows selected voltage and current unbalance measurement (U ⁺ , U ⁻ , U ⁰ , I ⁺ , I ⁻ , I ⁰ , u ⁻ , u ⁰ , i ⁻ , i ⁰).
F4	METER UNBAL.	Switches to PHASE DIAGRAM view. Switches to UNBALANCE DIAGRAM view.

	TREND	Switches to TREND view (available only during recording).
		Moves cursor and selects time interval (IP) for observation.
	ESC	Returns to the “MEASUREMENTS” submenu.

4.11 Temperature

Energy Master XA/Energy Master instrument is capable of measuring and recording temperature with Temperature probe A 1354¹. Temperature is expressed in both units, Celsius and Fahrenheit degrees. See following sections for instructions how to start recording. In order to learn how to set up neutral clamp input with the temperature sensor, see section 5.2.5.

¹ Optional accessory

4.11.1 Meter

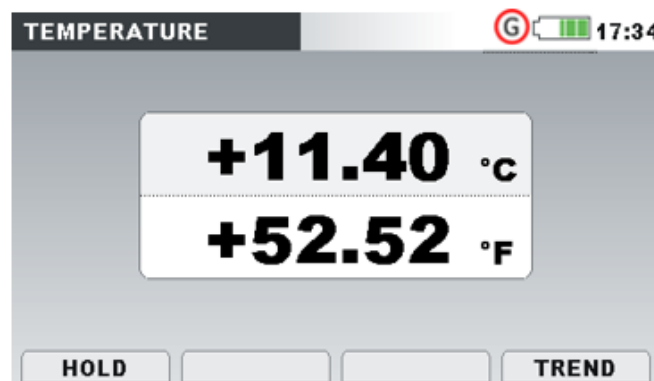





Figure 4.42: Temperature meter screen

Table 4.40: Instrument screen symbols and abbreviations

°C	Current temperature in Celsius degrees
°F	Current temperature in Fahrenheit degrees

Table 4.41: Keys in Temperature meter screen

	HOLD	Holds measurement on display. Hold clock time will be displayed in the right top corner.
	RUN	Runs held measurement.
	METER	Switches to METER view.
	TREND	Switches to TREND view (available only during recording).
		Triggers Waveform snapshot.
	ESC	Returns to the “MEASUREMENTS” submenu.

4.11.2 Trend

Temperature measurement TREND can be viewed during the recording in progress. Records containing temperature measurement can be viewed from Memory list and by using PC software PowerView v3.0.

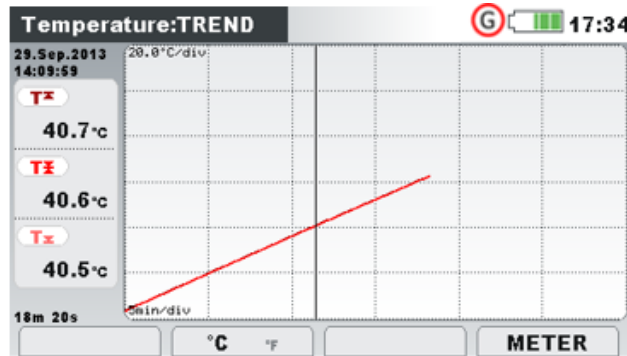

Figure 4.43: Temperature trend screen

Table 4.42: Instrument screen symbols and abbreviations

T:	Maximal (⌘), average (⌘) and minimal (⌘) temperature value for last recorded time interval (IP)
----	---

Table 4.43: Keys in Temperature trend screens

F2	°C °F	Shows temperature in Celsius degrees.
	°C °F	Shows temperature in Fahrenheit degrees.
	METER	Switches to METER view.
F4	TREND	Switches to TREND view (available only during recording).
ESC		Returns to the "MEASUREMENTS" submenu.

4.12 Underdeviation and overdeviation

Under deviation and over deviation parameters are useful when it is important to avoid, for example, having sustained under voltages being cancelled in data by sustained over voltages. Results can be seen in a tabular (METER) or a graphical form (TREND) view - which is active only while GENERAL RECORDER is active. See section 4.14 for instructions how to start recording. In order to understand meanings of particular parameter see section 6.1.12.

4.12.1 Meter

By entering DEVIATION option from MEASUREMENTS submenu, the UNDER/OVER DEVIATION tabular screen is shown (see figure below).

	L1	L2	L3
Urms	229.0	230.5	230.5 v
Uunder	1.04	0.34	0.94 v
	1.02	0.54	0.97 %
Uover	1.07	0.25	0.90 v
	0.78	1.21	0.60 %

Figure 4.44: Underdeviation and overdeviation table screen

Description of symbols and abbreviations used in METER screen is shown in table below.

Table 4.44: Instrument screen symbols and abbreviations

Urms	True effective value $U_1, U_2, U_3, U_{12}, U_{23}, U_{31}$
Uunder	Instantaneous underdeviation voltage U_{Under} expressed in voltage and % of nominal voltage
Uover	Instantaneous overdeviation voltage U_{Over} expressed in voltage and % of nominal voltage

Table 4.45: Keys in Underdeviation and overdeviation (METER) screen

	HOLD	Holds measurement on display. Hold clock time will be displayed in the right top corner.
	RUN	Runs held measurement.
		Selects between trending various parameters
		Shows under/over deviations measurements for all phase voltages
	METER	Shows under/over deviations measurements for all phase-to-phase voltages
	TREND	Switches to METER view.
		Switches to TREND view (available only during recording).
		Triggers Waveform snapshot.
		Returns to the "MEASUREMENTS" submenu.

4.12.2 Trend

During active recording TREND view is available (see section 4.14 for instructions how to start recording). Underdeviation and overdeviation parameters can be observed by cycling function key F4 (METER -TREND).

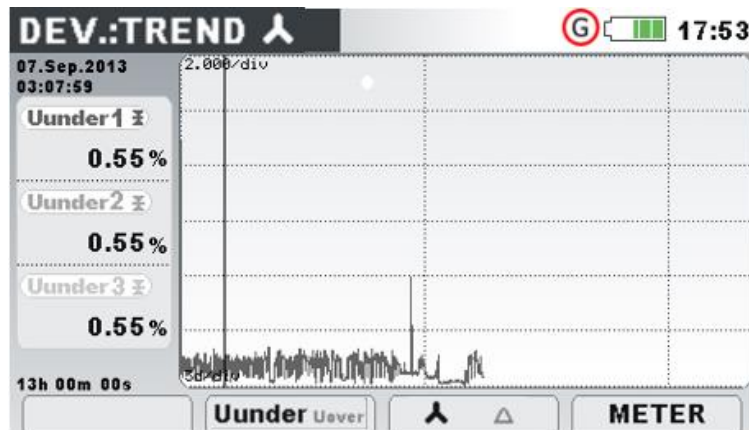

Figure 4.45: Underdeviation and overdeviation TREND screen

Table 4.46: Instrument screen symbols and abbreviations

Uunder1	Interval average (\bar{x}) value of corresponding underdeviation voltage $U_{1Under}, U_{2Under}, U_{3Under}, U_{12Under}, U_{23Under}, U_{31Under}$, expressed in % of nominal voltage.
Uunder2	
Uunder3	
Uunder12	
Uunder22	
Uunder31	
Uover1	Interval average (\bar{x}) value of corresponding overdeviation voltage $U_{1Over}, U_{2Over}, U_{3Over}, U_{12Over}, U_{23Over}, U_{31Over}$, expressed in % of nominal voltage.
Uover2	
Uover3	
Uover12	
Uover23	
Uover31	

Table 4.47: Keys in Underdeviation and Overdeviation (TREND) screens

F2	Under over	Selects between the following options:
	Under Over	Shows underdeviation trends
F3		Shows trends for all phase under/over deviations
		Shows trends for all lines under/over deviations
F4	METER	Switches to METER view.
	TREND	Switches to TREND view (available only during recording).
		Moves cursor and selects time interval (IP) for observation.
ESC		Returns to the "MEASUREMENTS" submenu.

4.13 Signalling

Mains signalling voltage, called “ripple control signal” in certain applications, is a burst of signals, often applied at a non-harmonic frequency, that remotely control industrial equipment, revenue meters, and other devices. Before observing signalling measurements, user should set-up signalling frequencies in signalling setup menu (see section 4.21.4).

Results can be seen in a tabular (METER) or a graphical form (TREND) - which is active only while GENERAL RECORDER is active. See section 4.14 for instructions how to start recording. In order to understand meanings of particular parameter see section 6.1.9.

4.13.1 Meter

By entering SIGNALLING option from MEASUREMENTS submenu, the SIGNALLING tabular screen is shown (see figure below).

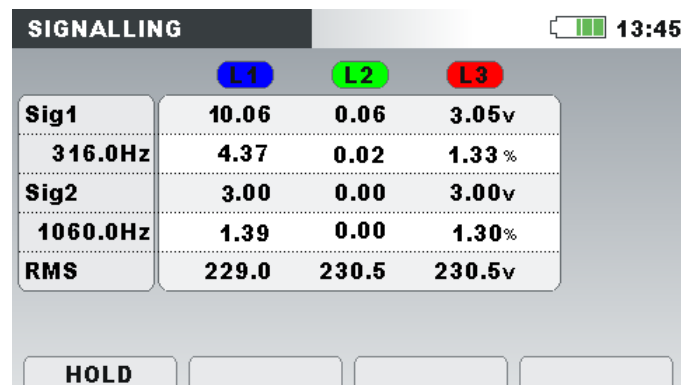



Figure 4.46: Signalling meter screen

Description of symbols and abbreviations used in METER screen is shown in table below.

Table 4.48: Instrument screen symbols and abbreviations

Sig1 316.0 Hz	True effective value signal voltage (U_{Sig1} , U_{Sig2} , U_{Sig3} , U_{Sig12} , U_{Sig23} , U_{Sig31}) for a user-specified carrier frequency (316.0 Hz in shown example) expressed in Volts or percent of fundamental voltage
Sig2 1060.0 Hz	True effective value signal voltage (U_{Sig1} , U_{Sig2} , U_{Sig3} , U_{Sig12} , U_{Sig23} , U_{Sig31}) for a user-specified carrier frequency (1060.0 Hz in shown example) expressed in Volts or percent of fundamental voltage
RMS	True effective value of phase or phase to phase voltage U_{Rms} (U_1 , U_2 , U_3 , U_{12} , U_{23} , U_{31})

Table 4.49: Keys in Signalling (METER) screen

	HOLD	Holds measurement on display. Hold clock time will be displayed in the right top corner.
	RUN	Runs held measurement.
	METER	Switches to METER view.

TREND	Switches to TREND view (available only during recording).
F4	TABLE Switches to TABLE view (available only during recording).
	Triggers Waveform snapshot.
ESC	Returns to the "MEASUREMENTS" submenu.

4.13.2 Trend

During active recording TREND view is available (see section 4.14 for instructions how to start recording). Signalling parameters can be observed by cycling function key F4 (METER -TREND).

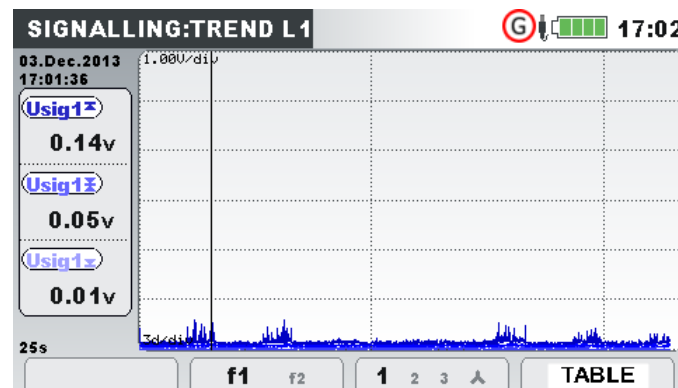

Figure 4.47: Signalling trend screen

Table 4.50: Instrument screen symbols and abbreviations









Usig1, Usig2, Usig3, Usig12, Usig23, Usig31	Maximal () , average () and minimal () value of (U _{Sig1} , U _{Sig2} , U _{Sig3} , U _{Sig12} , U _{Sig23} , U _{Sig31}) signal voltage for a user-specified Sig1/Sig2 frequency (Sig1 = 316.0 Hz / Sig2 = 1060.0 Hz in shown example).
14.Nov.2013 13:50:00	Timestamp of interval (IP) selected by cursor.
22h 25m 00s	Current GENERAL RECORDER time (Days hours:min:sec)

Table 4.51: Keys in Signalling (TREND) screen

F2	f1 f2	Selects between the following options: Shows signal voltage for a user-specified signalling frequency (Sig1).
	f1 f2	Shows signal voltage for a user-specified signalling frequency (Sig2).
F3	1 2 3 	Selects between trending various parameters: Shows signalling for phase 1
	1 2 3 	Shows signalling for phase 2
	1 2 3 	Shows signalling for phase 3
	1 2 3 	Shows signalling for all phases (average only)

	12 23 31 Δ	Shows signalling for phase-to-phase voltage L12.
	12 23 31 Δ	Shows signalling for phase-to-phase voltage L23.
	12 23 31 Δ	Shows signalling for phase-to-phase voltage L31.
	12 23 31 Δ	Shows signalling for all phase-to-phase voltages (average only).
	METER	Switches to METER view.
F4	TREND	Switches to TREND view (available only during recording).
	TABLE	Switches to TABLE view (available only during recording).
		Moves cursor and select time interval (IP) for observation.
		Returns to the "MEASUREMENTS" submenu.

4.13.3 Table

During active recording TABLE view is available (see section 4.14 for instructions how to start recording), by cycling function key F4 (METER –TREND - TABLE). Signalling events can be here observed as required by standard IEC 61000-4-30. For each signalling event instrument capture waveform which can be observed in PowerView.

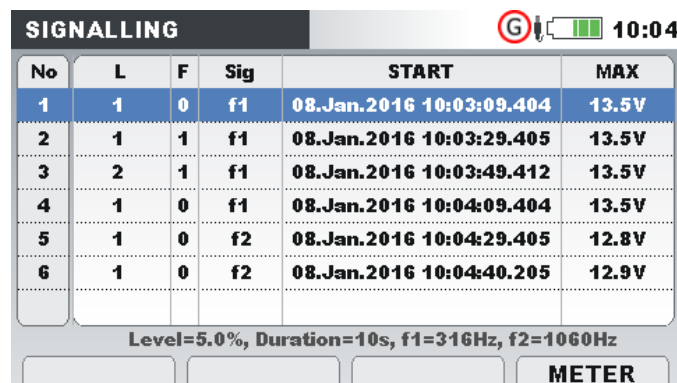

No	L	F	Sig	START	MAX
1	1	0	f1	08.Jan.2016 10:03:09.404	13.5V
2	1	1	f1	08.Jan.2016 10:03:29.405	13.5V
3	2	1	f1	08.Jan.2016 10:03:49.412	13.5V
4	1	0	f1	08.Jan.2016 10:04:09.404	13.5V
5	1	0	f2	08.Jan.2016 10:04:29.405	12.8V
6	1	0	f2	08.Jan.2016 10:04:40.205	12.9V

Level=5.0%, Duration=10s, f1=316Hz, f2=1060Hz

METER





Figure 4.48: Signalling table screen

Table 4.52: Instrument screen symbols and abbreviations

No	Signalling event number
L	Phases on which signalling event occurred
F	Flag indication <ul style="list-style-type: none"> 0 – none of intervals are flagged 1 – at least one of intervals inside recorded signalling is flagged
Sig	Frequency on which signalling occurred, defined as "Sign. 1" frequency (f1) and "Sign. 2" frequency (f2) in SIGNALLING SETUP menu. See 4.21.4 for details.
START	Time when observed Signalling voltage crosses threshold boundary.

MAX	Maximal voltage level recorder captured during signalling events
Level	Threshold level in % of nominal voltage Un, defined in SIGNALLING SETUP menu. See 4.21.4 for details.
Duration	Duration of captured waveform, defined in SIGNALLING SETUP menu. See 4.21.4 for details.
f1	1 st observed signalling frequency.
f2	2 nd observed signalling frequency.

Table 4.53: Keys in Signalling (TABLE) screen

	METER	Switches to METER view.
	TREND	Switches to TREND view (available only during recording).
	TABLE	Switches to TABLE view (available only during recording).
		Moves cursor through signalling table.
	ESC	Returns to the "MEASUREMENTS" submenu.

4.14 General Recorder

Energy Master XA/Energy Master has ability to record measured data in the background. By entering GENERAL RECORDER option from RECORDERS submenu, recorder parameters can be customized in order to meet criteria about interval, start time and duration for the recording campaign. General recorder setup screen is shown below:

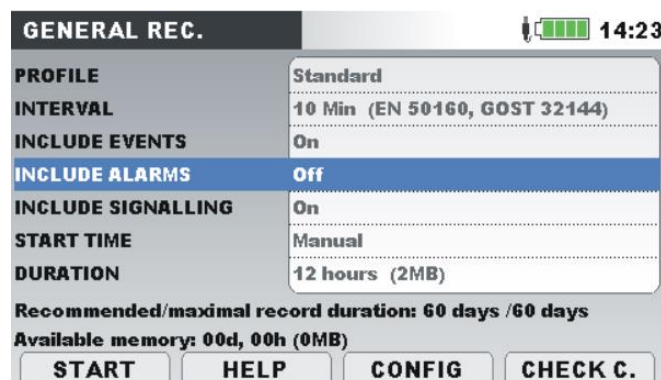



Figure 4.49: General recorder setup screen

Description of General recorder settings is given in the following table:



Table 4.54: General recorder settings description and screen symbols

	General recorder is active, waiting for start condition to be met. After start conditions are met (defined start time), instrument
---	--

	will capture waveform snapshot and start (activate) General recorder.
	<p>General recorder is active, recording in progress</p> <p>Note: Recorder will run until one of the following end conditions is met:</p> <ul style="list-style-type: none"> • STOP key was pressed by user • Given Duration criteria was met • Maximal record length was reached • SD CARD is full <p>Note: If recorder start time is not explicitly given, recorder start depends on Real Time clock multiple of interval. For example: recorder is activated at 12:12 with 5-minute interval. Recorder will actually start at 12:15.</p> <p>Note: If during record session instrument batteries are drained, due to long interruption for example, instrument will shut down automatically. After power restauration, it will automatically start new recording session.</p>
	<p>Include Voltage events (with waveform) or Include Alarms (with waveform) option is selected. Icon show that waveform recorder is active, waiting for trigger</p> <p>Note: Waveform recording available only at Energy Master XA</p>
	<p>Voltage event or alarm waveform recorder is active, waveform recording is in progress</p> <p>Note: Waveform recording available only at Energy Master XA</p>
Profile	<p>Select recording profile:</p> <ul style="list-style-type: none"> • Standard profile. Include all measurement in record. Suitable for most PQ measurement • Limited profile. Include limited set of measurements (most important). Suitable for long records with short interval (1-week record with 1 second interval). See section 5.4 for details.
Interval	<p>Define the measured interval. Available settings are from 1 second to 120 minutes.</p> <p>Available intervals: 1 sec, 3 sec, 5 sec, 10 sec, 1 min, 2 min, 5 min, 10 min, 15 min, 30 min, 60 min, 120 min</p> <p>Note: In case, that measured period is shorter than 10 seconds, than we not suggest to simultaneously detection of Event Waveforms and Transient, which could slowdown the analyser and may cause a problem saving data to the SD card (MI 2884 only).</p>
Include events	<p>Select whether events are included in the record.</p> <ul style="list-style-type: none"> • On: Record events signatures in table form (see 4.17 for details) • On (with waveforms): Records events signatures in table form and capture event waveform using Waveform recorder with Event type trigger and set

	duration defined in Waveform recorder setup screen (see 6.1.13 for details). Note: Waveform recording available only at Energy Master XA
	<ul style="list-style-type: none"> • Off: Events are not recorded
Include alarms	<p>Select whether alarms are included in the record.</p> <ul style="list-style-type: none"> • On: Record alarm signatures in table form (see 4.18 for details) • On (with waveforms): Records alarm signatures in table form and capture alarm waveform by using Waveform recorder with Alarm type trigger and set duration defined in Waveform recorder setup screen (see 6.1.14 for details). Note: Waveform recording available only at Energy Master XA • Off: Alarms are not recorded
Include signalling	<p>Select whether signalling events according to the IEC 61000-4-30 should be included in the record.</p> <ul style="list-style-type: none"> • On: Signalling events included in the record • Off: Signalling events are not recorded
Start time	<p>Define start time of recording:</p> <ul style="list-style-type: none"> • Manual, pressing function key F1 • At the given time and date.
Duration	<p>Define recording duration. General recorder will record measurement for given time duration:</p> <ul style="list-style-type: none"> • Manual, • 1, 6 or 12 hours, or • 1, 2, 3, 7, 15, 30, 60 days.
Recommended/maximal record duration:	Show recommended and maximal Duration parameter for given recording Interval.
Available memory	Show SD card free space

Table 4.55: Keys in General recorder setup screen

	START	Starts the recorder.
	STOP	Stops the recorder.
	HELP	Show help screen where it's explained which measurements will be recorded with Limited and Standard profile.

GENERAL REC. HELP		11:04	
RECORD PROFILE	Limited	Standard	
U,I,f	✓	✓	
P,Q,S, ENERGY	AVG	✓	
FREQUENCY 10s	X	✓	
FLICKERS	✓	✓	
UNBALANCE	✓	✓	
HARMONICS	1-50, AVG	✓	
INTERHARM.	X	✓	
TEMPERATURE	✓	✓	
SIGNALLING	✓	✓	
UNDER/OVER	✓	✓	

See section 5.4 for details.



CONFIG

Shortcut to Connection setup. See 5.2 for details.



CHECK C.

Check connection settings. See 4.21.1 for details.



Enters recorder starting date/time setup.

Keys in Set start time window:

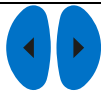

Selects parameter to be changed.



Modifies parameter.



Confirms selected option.



Exits Set start time window without modifications.



Selects parameter to be changed.



Modifies parameter.



Returns to the "RECORDERS" submenu.

4.15 Waveform/inrush recorder (available at Energy Master XA)

Waveform recording is a powerful tool for troubleshooting and capturing current and voltage waveforms and inrushes. Waveform recorder saves a defined number of periods of voltage and current on a trigger occurrence. Each recording consists of pre-trigger interval (before trigger) and post-trigger interval (after trigger).

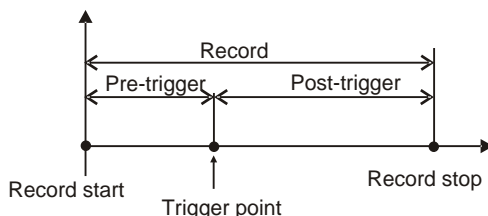

Figure 4.50: Triggering in waveform record

4.15.1 Setup

By entering WAVEFORM RECORDER from the RECORDERS submenu, the following setup screen is shown:

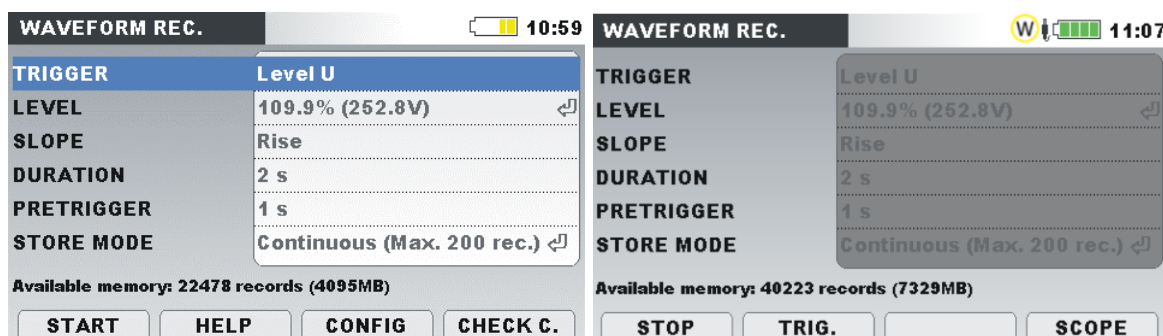

Figure 4.51: Waveform recorder setup screen

Table 4.56: Waveform recorder settings description and screen symbols

	Waveform recorder is active, waiting for trigger
	Waveform recorder is active, recording in progress
Trigger	<p>Trigger source set up:</p> <ul style="list-style-type: none"> • Events – triggered by voltage event (see 4.21.2); • Alarms – triggered by alarm activation (see 4.21.3); • Events & Alarms – triggered by alarm or event; • Level U – triggered by voltage level; • Level I – triggered by current level (inrush). • Interval – periodical trigger for given time period (each 10 minutes for example).
Level*	Voltage or current level in % of nominal voltage or current and in (V or A), which will trigger recording
Slope*	<ul style="list-style-type: none"> • Rise – triggering will occur only if voltage or current rise above given level • Fall - triggering will occur only if voltage or current fall below given level





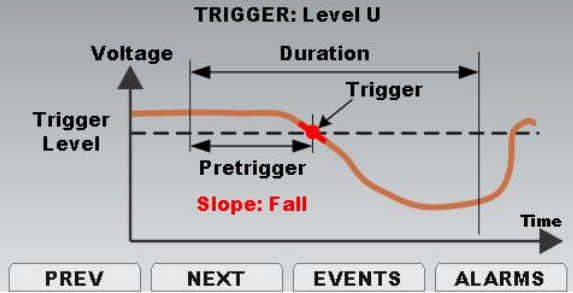
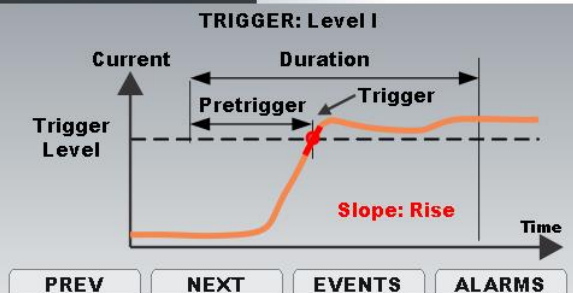

	<ul style="list-style-type: none"> • Any – triggering will occur if voltage or current rise above or fall below given level
Duration	Record length.
Pretrigger	Recorded interval before triggering occurs.
Interval	Interval between two-time triggered waveforms in Interval trigger type
Store mode	Store mode setup: <ul style="list-style-type: none"> • Single – waveform recording ends after first trigger; • Continuous (Max. 200 record)– consecutive waveform recording until user stops the measurement or instrument runs out of storage memory. Every consecutive waveform recording will be treated as a separate record. By default, maximal 200 records can be recorded. This value can be changed, if necessary (up to 1500 records maximum).

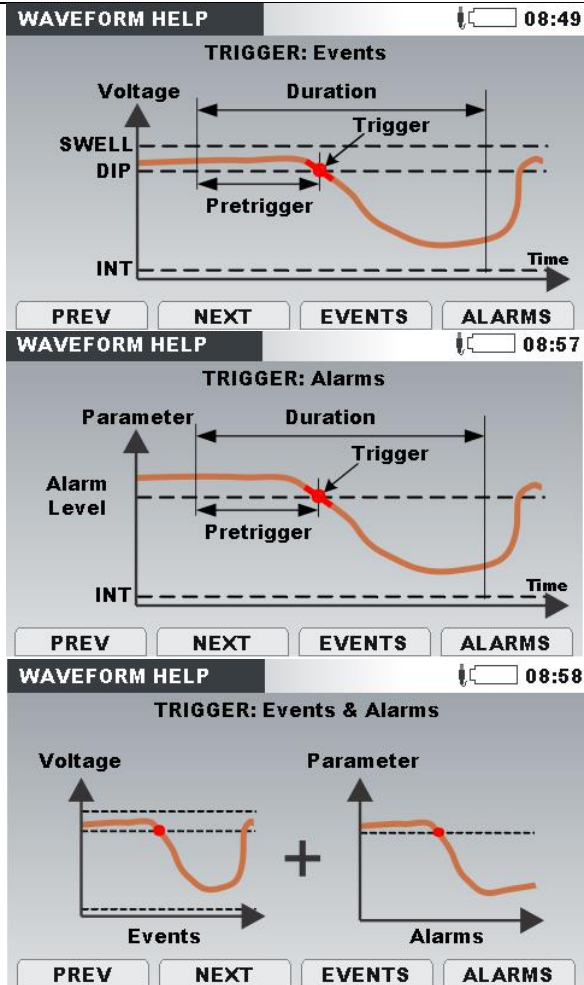
* Available only if Level U or Level I triggering is selected.

Table 4.57: Keys in Waveform recorder setup screen

<div style="background-color: #0070C0; color: white; padding: 5px; border-radius: 10px; width: 40px; margin: 0 auto;">F1</div>	START STOP	<p>Starts waveform recording. Stops waveform recording.</p> <p>Note: If user forces waveform recorder to stop before trigger occurs, no data will be recorded. Data recording occurs only when trigger is activated.</p>
<div style="background-color: #0070C0; color: white; padding: 5px; border-radius: 10px; width: 40px; margin: 0 auto;">F2</div>	TRIG. HELP	<p>Manually generates trigger condition and starts recording. Show triggering help screens. See 6.1.19 for details.</p> <div style="border: 1px solid gray; padding: 5px; margin-bottom: 10px;"> <p style="text-align: center; margin: 0;">WAVEFORM HELP 08:39</p> <p style="text-align: center; margin: 0;">TRIGGER: Level U</p>  <p style="text-align: center; margin: 0;">PREV NEXT EVENTS ALARMS</p> </div> <div style="border: 1px solid gray; padding: 5px;"> <p style="text-align: center; margin: 0;">WAVEFORM HELP 08:48</p> <p style="text-align: center; margin: 0;">TRIGGER: Level I</p>  <p style="text-align: center; margin: 0;">PREV NEXT EVENTS ALARMS</p> </div>



	CONFIG	Shortcut to CONNECTION SETUP menu. See 4.21.1 for details.
	LAST REC	Show last captured waveform record from MEMORY LIST.
	SCOPE	Switches to SCOPE view. (Active only if recording in progress).
	CHECK C.	Check connection settings. See 4.21.1 for details.
		Selects parameter to be changed.
		Modifies parameter.
		Enter into submenu (↵).
		Returns to the "RECORDERS" submenu.

4.15.2 Capturing waveform

Following screen opens when a user switches to SCOPE view.

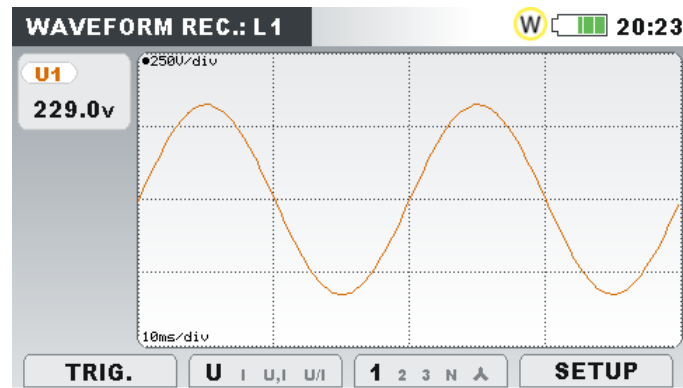

Figure 4.52: Waveform recorder capture screen

Table 4.58: Instrument screen symbols and abbreviations

	Waveform recorder is active, waiting for trigger
	Waveform recorder is active, recording in progress
U1, U2, U3, Un	True effective value of phase voltage: U_{1Rms} , U_{2Rms} , U_{3Rms} , U_{NRms}
U12, U23, U31	True effective value of phase-to-phase (line) voltage: U_{12Rms} , U_{23Rms} , U_{31Rms}
I1, I2, I3, In	True effective value of current: I_{1Rms} , I_{2Rms} , I_{3Rms} , I_{NRms}

Table 4.59: Keys in Waveform recorder capture screen

	TRIG.	Manually generates trigger condition (Active only if recording is in progress).
		Selects which waveforms to show: Shows voltage waveform.
		Shows current waveform.
		Shows voltage and current waveforms on single graph.
		Shows voltage and current waveforms on separate graphs.
		Selects between phase, neutral, all-phases and line view: Shows waveforms for phase L1.
		Shows waveforms for phase L2.
		Shows waveforms for phase L3.
		Shows waveforms for neutral channel.
		Shows waveforms for all phases.
		Shows waveforms for phase-to-phase voltage L12.
		Shows waveforms for phase-to-phase voltage L23.
		Shows waveforms for phase-to-phase voltage L31.
	SETUP	Switches to SETUP view. (Active only if recording in progress).
		Selects which waveform to zoom (only in U, I or U/I).
		Sets vertical zoom.



Sets horizontal zoom.



Returns to the “WAVEFORM RECORDER” setup screen.

4.15.3 Captured waveform

Captured waveforms can be viewed from the Memory list menu.

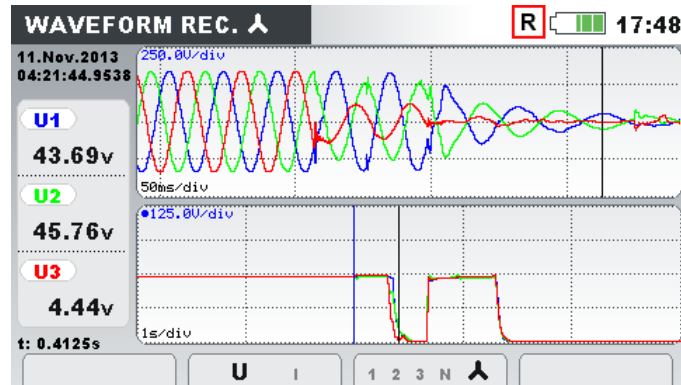

Figure 4.53: Captured waveform recorder screen

Table 4.60: Instrument screen symbols and abbreviations

R	Memory list recall. Shown screen is recalled from memory
t:	Cursor position in seconds (regarding to trigger time – blue line on graph)
u1(t), u2(t), u3(t), un(t)	Samples value of phase voltages U_1, U_2, U_3, U_N .
u12(t), u23(t), u31(t)	Samples value of phase-to-phase voltages U_{12}, U_{23}, U_{31} .
i1(t), i2(t), i3(t), in(t)	Samples value of phase currents I_1, I_2, I_3, I_N .
U1, U2, U3, Un	True effective half cycle phase voltage $U_{Rms(1/2)}$
U12, U23, U31	True effective half cycle phase to phase voltage $U_{Rms(1/2)}$
I1, I2, I3, In	True effective half cycle value $I_{Rms(1/2)}$

Table 4.61: Keys in captured waveform recorder screens

		Selects between the following options:
F2	U U, I U/I	Shows voltage waveform.
	I U, I U/I	Shows current waveform.
	U I U, I U/I	Shows voltage and current waveforms (single mode).
	U I U, I U/I	Shows voltage and current waveforms (dual mode).
F3	1 2 3 N ^	Selects between phase, neutral, all-phases and view:
	1 2 3 N ^	Shows waveforms for phase L1.
	1 2 3 N ^	Shows waveforms for phase L2.
	1 2 3 N ^	Shows waveforms for phase L3.
	1 2 3 N ^	Shows waveforms for neutral channel.
	1 2 3 N ^	Shows all phases waveforms.
12 23 31 Δ	Shows waveforms for phase-to-phase voltage L12.	

	Shows waveforms for phase-to-phase voltage L23.
	Shows waveforms for phase-to-phase voltage L31.
	Shows all phase-to-phase waveforms.
	Sets vertical zoom.
	Moves cursor.
	Toggles between sample value and true effective half cycle value at cursor position. Toggles cursor between voltage and current (only in U, I or U/I).
	Returns to the "MEMORY LIST" submenu.

4.16 Transient recorder (available at Energy Master XA)

Transient is a term for **short, highly damped** momentary voltage or current disturbance. A transient recording is recording with the 30.6 kSamples/sec sampling rate. The principle of measurement is similar to waveform recording, but with higher sampling rate. In contrary to waveform recording, where recording is triggered based on RMS values, trigger in transient recorder is based on sample values.

4.16.1 Setup

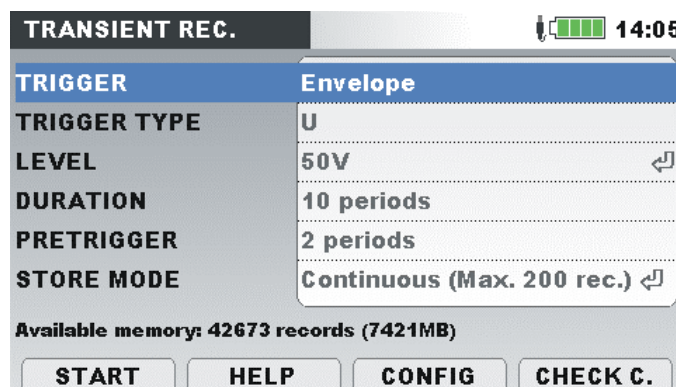

Figure 4.54: Transient recorder setup screen

Table 4.62: Transient recorder settings description and screen symbols

	Transient recorder is active, waiting for trigger
	Transient recorder is active, recording in progress

Trigger

Envelope: Trigger value is based on envelope within voltage/current that is expected. As reference, voltage/current waveform from previous cycle is taken. If current sample is not within envelope, triggering will occur. See 6.1.20 for details.

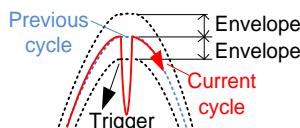







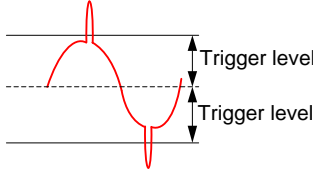

	<p>Level: Trigger will occur if any sample within period is greater than defined absolute trigger level. See 6.1.20 for details.</p> 
Type	<p>U: Trigger on transients at active voltage (phase/line) channels Un: Trigger on transients at Ground to Neutral voltage channel I: Trigger on transients at active phase current channels In: Trigger on transients at Neutral current channel</p>
Level	Trigger level in voltage/current
Duration	Record length in periods of fundamental frequency
Pretrigger	Recorded intervals before triggering occur.
Store mode	<p>Store mode setup:</p> <ul style="list-style-type: none"> • Single – transient recording ends after first trigger • Continuous (Max. 200 rec.) – consecutive transient recording until user stops the measurement or instrument runs out of storage memory. Every consecutive transient recording will be treated as a separate record. <p>By default, maximal 200 records can be recorded. This value can be changed, if necessary (up to 1500 records maximum).</p>

Table 4.63: Keys in Transient recorder setup screen

	START STOP	Starts transient recorder. Stops transient recorder. Note: If user forces transient recorder to stop before trigger occurs, no data is recorded. Data recording occurs only when trigger is activated.
	TRIG. HELP	Manually generates trigger condition and starts recording. Show triggering help screens. See 6.1.20 for details.
	CONFIG	Shortcut to CONNECTION SETUP menu. See 4.21.1 for details.
	CHECK C.	Check connection settings. See 4.21.1 for details.
		Selects parameter to be changed.
		Modifies parameter.
		Enter into submenu (↵).

ESC Returns to the “RECORDERS” submenu.

4.16.2 Capturing transients

After transient recorder is started, instrument waits for trigger occurrence. This can be seen by observing status bar, where icon **T** is present. If trigger conditions are met, recording will be started.

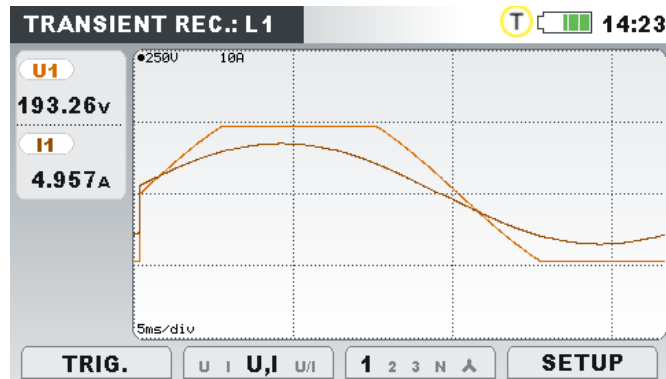

Figure 4.55: Transient recorder capture screen

Table 4.64: Instrument screen symbols and abbreviations

T	Transient recorder is active, waiting for trigger
T	Transient recorder is active, recording in progress
U1, U2, U3, Un	True 1-cycle effective value of phase voltage: U_{1Rms} , U_{2Rms} , U_{3Rms} , U_{NRms}
U12, U23, U31	True 1-cycle effective value of phase-to-phase voltage: U_{12Rms} , U_{23Rms} , U_{31Rms}
I1, I2, I3, In	True 1-cycle effective value of current: I_{1Rms} , I_{2Rms} , I_{3Rms} , I_{NRms}

Table 4.65: Keys in Transient recorder capture screen

F1	TRIG.	Manually generates trigger condition (Active only if recording is in progress).
F2	U U,I U/I	Selects which waveforms to show: Shows voltage waveform.
	I U,I U/I	Shows current waveform.
	U I U,I U/I	Shows voltage and current waveforms on single graph.
	U I U,I U/I	Shows voltage and current waveforms on separate graphs.
F3	1 2 3 N ^	Selects between phase, neutral, all-phases and line view: Shows waveforms for phase L1.
	1 2 3 N ^	Shows waveforms for phase L2.
	1 2 3 N ^	Shows waveforms for phase L3.
	1 2 3 N ^	Shows waveforms for neutral channel.
	1 2 3 N ^	Shows waveforms for all phases.
	12 23 31 Δ	Shows waveforms for phase-to-phase voltage L12.
	12 23 31 Δ	Shows waveforms for phase-to-phase voltage L23.
12 23 31 Δ	Shows waveforms for phase-to-phase voltage L31.	

12 23 31 Δ	Shows waveforms for all phase-to-phase voltages.
F4 SETUP	Switches to SETUP view (Active only if recording in progress).
▲ ▼	Sets vertical zoom.
ENTER	Selects which waveform to zoom (only in U, I or U/I).
ESC	Returns to the “TRANSIENT RECORDER” setup screen.

4.16.3 Captured transients

Captured transient records can be viewed from the Memory list where captured waveforms can be analysed. Trigger occurrence is marked with the blue line, while cursor position line is marked in black.

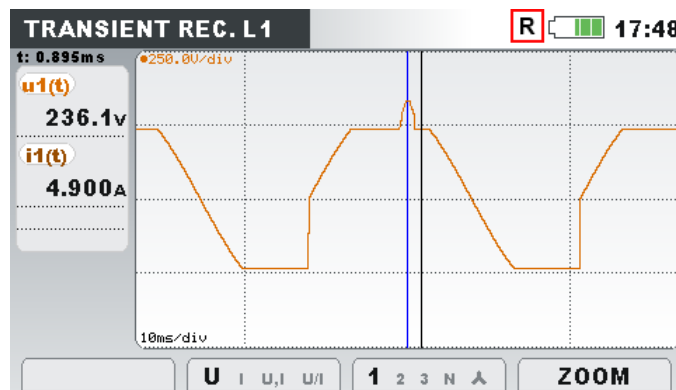

Figure 4.56: Captured transient recorder screen

Table 4.66: Instrument screen symbols and abbreviations

R	Memory list recall. Shown screen is recalled from memory
t:	Cursor position regarding to trigger time (blue line on graph)
u1(t), u2(t), u3(t), un(t)	Samples value of phase voltages U1, U2, U3, UN.
u12(t), u23(t), u31(t)	Samples value of phase-to-phase voltages U12, U23, U31.
i1(t), i2(t), i3(t), in(t)	Samples value of phase currents I1, I2, I3, IN.

Table 4.67: Keys in captured transient recorder screens

		Selects between the following options:
	U I U,I U/I	Shows voltage waveform.
F2	U I U,I U/I	Shows current waveform.
	U I U,I U/I	Shows voltage and current waveforms (single mode).
	U I U,I U/I	Shows voltage and current waveforms (dual mode).
		Selects between phase, neutral, all-phases and view:
F3	1 2 3 N ▲	Shows waveforms for phase L1.

	1 2 3 N ▲	Shows waveforms for phase L2.
	1 2 3 N ▲	Shows waveforms for phase L3.
	1 2 3 N ▲	Shows waveforms for neutral channel.
	1 2 3 N ▲	Shows waveforms for all phases.
	12 23 31 Δ	Shows waveforms for phase-to-phase voltage L12.
	12 23 31 Δ	Shows waveforms for phase-to-phase voltage L23.
	12 23 31 Δ	Shows waveforms for phase-to-phase voltage L31.
	12 23 31 Δ	Shows waveforms for all phase-to-phase voltages.

	ZOOM	Sets horizontal zoom
---	------	----------------------

		Sets vertical zoom.
---	--	---------------------

		Moves cursor.
---	--	---------------

		Toggles cursor between voltage and current (only in U,I or U/I).
---	--	--

		Returns to the "MEMORY LIST" submenu.
---	--	---------------------------------------

4.17 Events table

In this table captured voltage dips, swells and interrupts are shown. Note that events appear in the table after finishing, when voltage return to the normal value. All events can be grouped according to IEC 61000-4-30. Additionally, for troubleshooting purposes events can be separated by phase. This is toggled by pressing function key F1.

4.17.1.1 Group view

In this view voltage event are grouped according to IEC 61000-4-30 (see section 6.1.12 for details). Table where events are summarized is shown below. Each line in table represents one event, described by event number, event start time, duration and level. Additionally, in colon "T" event characteristics (Type) is shown (see table below for details).



No	L	START	T	Level	Duration
1	1	02:22:01.240	D	179.92	0h00m4.010s
2	2	02:22:17.247	S	258.83	0h00m9.990s
3	1 2 3	02:22:39.240	DI	0.06	0h00m12.013s

Figure 4.57: Voltage events in group view screen

By pressing "ENTER" on particular event we can examine event details. Event is split by phase events and sorted by start time.



No	L	START	T	Level	Duration
3	1	02:22:39.240	D	0.06	0h00m10.010s
4	1	02:22:39.250	I	0.06	0h00m9.990s
5	2	02:22:41.237	D	0.06	0h00m10.010s
6	3	02:22:41.244	D	1.03	0h00m10.010s
7	3	02:22:41.254	I	1.03	0h00m9.980s
8	2	02:22:41.257	I	0.06	0h00m9.980s









Figure 4.58: Voltage event in detail view screen

Table 4.68: Instrument screen symbols and abbreviations

Date	Date when selected event has occurred
No.	Unified event number (ID)
L	Indicate phase or phase-to-phase voltage where event has occurred: 1 – event on phase U ₁

	2 – event on phase U ₂ 3 – event on phase U ₃ 12 – event on voltage U ₁₂ 23 – event on voltage U ₂₃ 31 – event on voltage U ₃₁ Note: This indication is shown only in event details, since one grouped event can have many phase events.
Start	Event start time (when first $U_{Rms(1/2)}$ value crosses threshold.
T	Indicates type of event or transition: D – Dip I – Interrupt S – Swell
Level	Minimal or maximal value in event U _{Dip} , U _{Int} , U _{Swell}
Duration	Event duration.

Table 4.69: Keys in Events table group view screens

	 	Group view is shown. Press to switch on “PHASE” view. Phase view is shown. Press to switch on “GROUP” view.																														
		Shows all types of events (dips and swell). Interrupts are treated as special case of voltage dip event. START time and Duration in table is referenced to complete voltage event.																														
		 <p>The screenshot shows an 'EVENTS' table with the following data:</p> <table border="1"> <thead> <tr> <th>No</th> <th>L</th> <th>START</th> <th>T</th> <th>Level</th> <th>Duration</th> </tr> </thead> <tbody> <tr> <td>1</td> <td>1</td> <td>02:22:01.240</td> <td>D</td> <td>179.92</td> <td>0h00m4.010s</td> </tr> <tr> <td>2</td> <td>2</td> <td>02:22:17.247</td> <td>S</td> <td>258.83</td> <td>0h00m9.990s</td> </tr> <tr> <td>3</td> <td>1 2 3</td> <td>02:22:39.240</td> <td>DI</td> <td>0.06</td> <td>0h00m12.013s</td> </tr> <tr> <td>4</td> <td>1 2 3</td> <td>02:39:45.237</td> <td>DI</td> <td>0.06</td> <td>0h00m14.017s</td> </tr> </tbody> </table>	No	L	START	T	Level	Duration	1	1	02:22:01.240	D	179.92	0h00m4.010s	2	2	02:22:17.247	S	258.83	0h00m9.990s	3	1 2 3	02:22:39.240	DI	0.06	0h00m12.013s	4	1 2 3	02:39:45.237	DI	0.06	0h00m14.017s
No	L	START	T	Level	Duration																											
1	1	02:22:01.240	D	179.92	0h00m4.010s																											
2	2	02:22:17.247	S	258.83	0h00m9.990s																											
3	1 2 3	02:22:39.240	DI	0.06	0h00m12.013s																											
4	1 2 3	02:39:45.237	DI	0.06	0h00m14.017s																											
		Shows poly-phase voltage interrupts only, according to the IEC 61000-4-30 requirements. START time and Duration in table is referenced to voltage interrupt only.																														
		 <p>The screenshot shows an 'EVENTS' table with the following data:</p> <table border="1"> <thead> <tr> <th>No</th> <th>L</th> <th>START</th> <th>T</th> <th>Level</th> <th>Duration</th> </tr> </thead> <tbody> <tr> <td>3</td> <td>1 2 3</td> <td>02:22:41.257</td> <td>I</td> <td>0.06</td> <td>0h00m7.983s</td> </tr> <tr> <td>4</td> <td>1 2 3</td> <td>02:39:47.254</td> <td>I</td> <td>0.06</td> <td>0h00m7.987s</td> </tr> </tbody> </table>	No	L	START	T	Level	Duration	3	1 2 3	02:22:41.257	I	0.06	0h00m7.983s	4	1 2 3	02:39:47.254	I	0.06	0h00m7.987s												
No	L	START	T	Level	Duration																											
3	1 2 3	02:22:41.257	I	0.06	0h00m7.983s																											
4	1 2 3	02:39:47.254	I	0.06	0h00m7.987s																											

Shows event statistics (by phases).

F4

STAT

EVENTS
G 17:53

L1
L2
L3

U	229.0	230.5	230.5 v
----------	-------	-------	---------

EVENTS

Swell:	37	37	37
Dip:	5	5	5
Int:	0	0	0

START: 01.Oct.2013 09:40:05.605

Curr. : 01.Oct.2013 09:40:37.606

EVENTS

EVENTS Returns to "EVENTS" view.

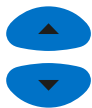

Selects event.



Enters detail event view.



Returns to Events table group view screen.
Returns to "RECORDERS" submenu.

4.17.1.2 Phase view

In this view voltage events are separated by phases. This is convenient view for troubleshooting. Additionally, user can use filters in order to observe only particular type of event on a specific phase. Captured events are shown in a table, where each line contains one phase event. Each event has an event number, event start time, duration and level. Additionally, in colon "T" type of event is shown (see table below for details).

EVENTS
G 17:53

Date 13.09.2013

No	L	START	T	Level	Duration
1	1	08:42:18.048	D	135.64	0h00m0.060s
2	1	08:42:20.048	D	135.66	0h00m0.060s
3	1	08:42:28.048	D	135.64	0h00m0.060s
4	12	08:42:30.045	D	135.64	0h00m0.090s
5	12	08:42:32.045	D	135.63	0h00m0.090s
6	12	08:42:34.045	D	135.64	0h00m0.090s
7	2	08:42:36.045	D	160.96	0h00m0.090s

Ph.
STAT

Figure 4.59: Voltage events screens















You can also see details of each individual voltage event and statistics of all events. Statistics show count registers for each individual event type by phase.

Table 4.70: Instrument screen symbols and abbreviations

Date	Date when selected event has occurred
------	---------------------------------------

No.	Unified event number (ID)
L	Indicate phase or phase-to-phase voltage where event has occurred: 1 – event on phase U_1 2 – event on phase U_2 3 – event on phase U_3 12 – event on voltage U_{12} 23 – event on voltage U_{23} 31 – event on voltage U_{31}
Start	Event start time (when first $U_{Rms(1/2)}$ value crosses threshold.
T	Indicates type of event or transition: D – Dip I – Interrupt S – Swell
Level	Minimal or maximal value in event U_{Dip} , U_{Int} , U_{Swell}
Duration	Event duration.

Table 4.71: Keys in Events table phase view screens

F1	 PH	Group view is shown. Press to switch on “PHASE” view.
	 PH	Phase view is shown. Press to switch on “GROUP” view.
F2	 DIP INT SWELL	Filters events by type: Shows all event types.
	 DIP INT SWELL	Shows dips only.
	 DIP INT SWELL	Shows interrupts only.
	 DIP INT SWELL	Shows swells only.
F3	 1 2 3 T	Filters events by phase: Shows only events on phase L1.
	 1 2 3 T	Shows only events on phase L2.
	 1 2 3 T	Shows only events on phase L3.
	 1 2 3 T	Shows events on all phases.
	 12 23 31 T	Shows only events on phases L12.
	 12 23 31 T	Shows only events on phases L23.
	 12 23 31 T	Shows only events on phases L31.
	 12 23 31 T	Shows events on all phases.
F4	 STAT	Shows event summary (by types and phases).

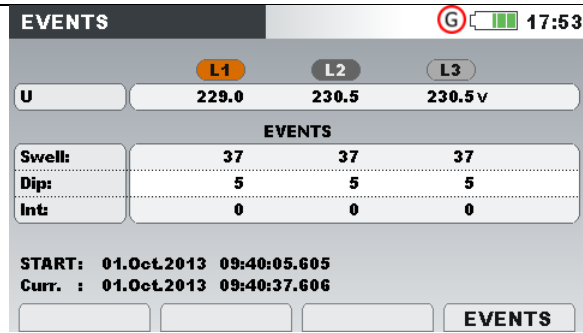

EVENTS Returns to EVENTS view.

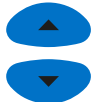

Selects event.



Enters detail event view.



Returns to Events table phase view screen.
Returns to the "RECORDERS" submenu.

4.18 Alarms table

This screen shows list of alarms which went off. Alarms are displayed in a table, where each row represents an alarm. Each alarm is associated with a start time, phase, type, slope, min/max value and duration (see 4.21.3 for alarm setup and 6.1.14 for alarm measurement details).

START	L	T	Slope	Min/Max	Duration
08:38:31.799	1	I	Rise	1000 A	22.200 sec
08:38:31.799	T	P+	Rise	681.2 kW	52.400 sec
08:40:00.199	T	P+	Rise	302.0 kW	12.000 sec
08:40:46.199	1	Uh3	Rise	9.83 %	15.800 sec
08:41:16.399	1	I	Rise	900.1 A	15.600 sec
08:41:16.399	T	P+	Rise	260.2 kW	15.800 sec

Figure 4.60: Alarms list screen



Table 4.72: Instrument screen symbols and abbreviations

Date	Date when selected alarm has occurred
Start	Selected alarm start time (when first U_{Rms} value cross threshold)
L	Indicate phase or phase-to-phase voltage where event has occurred: 1 – alarm on phase L ₁ 2 – alarm on phase L ₂ 3 – alarm on phase L ₃ 12 – alarm on line L ₁₂ 23 – alarm on line L ₂₃ 31 – alarm on line L ₃₁
Slope	Indicates alarms transition:

	<ul style="list-style-type: none"> • Rise – parameter has over-crossed threshold • Fall – parameter has under-crossed threshold
Min/Max	Minimal or maximal parameter value during alarm occurrence
Duration	Alarm duration.

Table 4.73: Keys in Alarms table screens

		Filters alarms according to the following parameters:
	<p>▲ UIF C. Pwr F. Pwr NF. Pwr Flick Sym H iH Sig Temp</p>	All alarms.
	<p>▲ UIF C. Pwr F. Pwr NF. Pwr Flick Sym H iH Sig Temp</p>	Voltage alarms.
	<p>▲ UIF C. Pwr F. Pwr NF. Pwr Flick Sym H iH Sig Temp</p>	Combined power alarms.
	<p>▲ UIF C. Pwr F. Pwr NF. Pwr Flick Sym H iH Sig Temp</p>	Fundamental power alarms.
F2	<p>▲ UIF C. Pwr F. Pwr NF. Pwr Flick Sym H iH Sig Temp</p>	Nonfundamental power alarms.
	<p>▲ UIF C. Pwr F. Pwr NF. Pwr Flick Sym H iH Sig Temp</p>	Flicker alarms.
	<p>▲ UIF C. Pwr F. Pwr NF. Pwr Flick Sym H iH Sig Temp</p>	Unbalance alarms.
	<p>▲ UIF C. Pwr F. Pwr NF. Pwr Flick Sym H iH Sig Temp</p>	Harmonics alarms.
	<p>▲ UIF C. Pwr F. Pwr NF. Pwr Flick Sym H iH Sig Temp</p>	Interharmonics alarms.
	<p>▲ UIF C. Pwr F. Pwr NF. Pwr Flick Sym H iH Sig Temp</p>	Signalling alarms.
	<p>▲ UIF C. Pwr F. Pwr NF. Pwr Flick Sym H iH Sig Temp</p>	Temperature alarms.
		Filters alarms according to phase on which they occurred:
	<p>1 2 3 N 12 23 31 T ▲</p>	Shows only alarms on phase L1.
	<p>1 2 3 N 12 23 31 T ▲</p>	Shows only alarms on phase L2.
	<p>1 2 3 N 12 23 31 T ▲</p>	Shows only alarms on phase L3.
	<p>1 2 3 N 12 23 31 T ▲</p>	Shows only alarms on neutral channel.
	<p>1 2 3 N 12 23 31 T ▲</p>	Shows only alarms on phases L12.
	<p>1 2 3 N 12 23 31 T ▲</p>	Shows only alarms on phases L23.
	<p>1 2 3 N 12 23 31 T ▲</p>	Shows only alarms on phases L31.
F3	<p>1 2 3 N 12 23 31 T ▲</p>	Shows only alarms on channels which are not channel dependent

	Shows all alarms.
	Selects an alarm.
	Returns to the "RECORDERS" submenu.

4.19 Rapid voltage changes (RVC) table

In this table captured RVC events are shown. Events appear in the table after finish, when voltage is in the steady state. RVC events are measured and represented according to IEC 61000-4-30. See 6.1.15 for details.

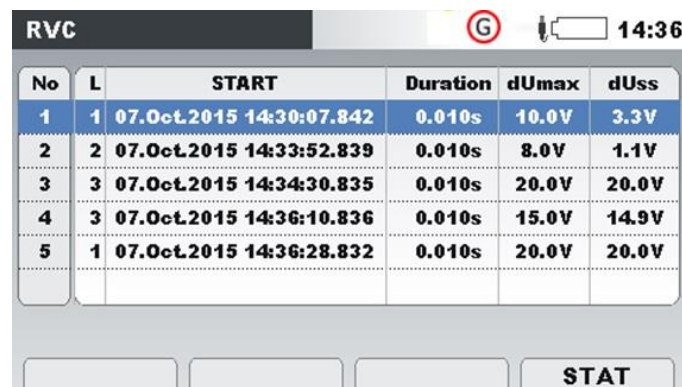







No	L	START	Duration	dUmax	dUss
1	1	07.Oct.2015 14:30:07.842	0.010s	10.0V	3.3V
2	2	07.Oct.2015 14:33:52.839	0.010s	8.0V	1.1V
3	3	07.Oct.2015 14:34:30.835	0.010s	20.0V	20.0V
4	3	07.Oct.2015 14:36:10.836	0.010s	15.0V	14.9V
5	1	07.Oct.2015 14:36:28.832	0.010s	20.0V	20.0V

Figure 4.61: RVC Events table group view screen

Table 4.74: Instrument screen symbols and abbreviations

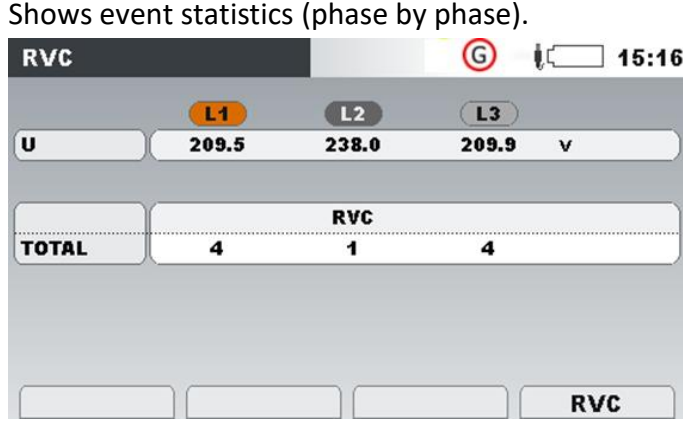
No.	Unified event number (ID)
L	Indicate phase or phase-to-phase voltage where event has occurred: 1 – event on phase U ₁ 2 – event on phase U ₂ 3 – event on phase U ₃ 12 – event on voltage U ₁₂ 23 – event on voltage U ₂₃ 31 – event on voltage U ₃₁
Start	Event start time (when first $U_{Rms(1/2)}$) value crosses threshold.
Duration	Event duration.
dMax	ΔU_{max} - maximum absolute difference between any of the $U_{Rms(1/2)}$ values during the RVC event and the final arithmetic mean 100/120 $U_{Rms(1/2)}$ value just prior to the RVC event.
dUss	ΔU_{ss} - is the absolute difference between the final arithmetic mean 100/120 $U_{Rms(1/2)}$ value just prior to the RVC event and the first arithmetic mean 100/120 $U_{Rms(1/2)}$ value after the RVC event.

Table 4.75: Keys in RVC Events table group view screens

	Shows event statistics (phase by phase).
	 
	Returns to RVC Events table group view screen.
	Selects RVC Event.
	
	Returns to RVC Events table group view screen. Returns to "RECORDERS" submenu.

4.20 Memory List

Using this menu user can view and browse saved records. By entering this menu, information about records is shown.

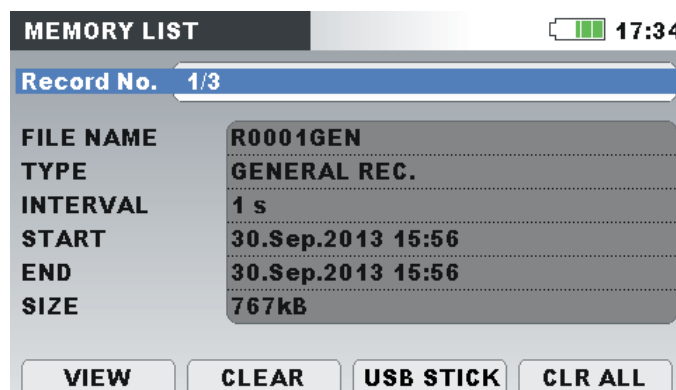











Figure 4.62: Memory list screen

Table 4.76: Instrument screen symbols and abbreviations

Record No	Selected record number, for which details are shown / Number of all records.
FILE NAME	Record name on SD Card. By convention file names are created by following rules: Rxxxxyyy.REC , where: <ul style="list-style-type: none"> • xxxx if record number 0000 ÷ 9999 • yyy represent record type

	<ul style="list-style-type: none"> ○ SNP – waveform snapshot ○ GEN – general record. General record generates also AVG, EVT, PAR, ALM, SEL files, which can be found on SD Card and are imported into PowerView.
Type	Indicates type of record, which can be one of following: <ul style="list-style-type: none"> • Snapshot, • General record.
Interval	General record recording interval (integration period)
Trigger	Trigger used for capturing waveform and transient record
Level	Trigger level
Slope	Trigger slope
Duration	Record duration
Start	General record start time.
End	General record stop time.
Size	Record size in kilobytes (kB) or megabytes (MB).

Table 4.77: Keys in Memory list screen

	VIEW	Views details of currently selected record.
	CLEAR	Clears selected record.
	USB STICK	Enable USB memory stick support.
	COPY	Copy current record to USB memory stick.
		Opens confirmation window for clearing all saved records.
		Keys in confirmation window:
	CLR ALL	 Selects YES or NO.
		 Confirms selection.
		 Exits confirmation window without clearing saved records.
		Browses through records (next or previous record).
		Returns to the “RECORDERS” submenu.

4.20.1 General Record

This type of record is made by GENERAL RECORDER. Record front page is similar to the GENERAL RECORDER setup screen, as shown on figure below.

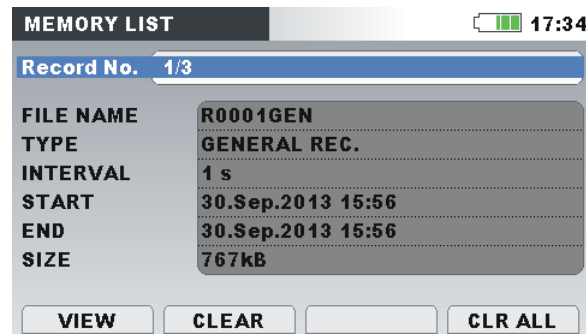

Figure 4.63: Front page of General record in MEMORY LIST menu

Table 4.78: Recorder settings description

Record No.	Selected record number, for which details are shown.
FILE NAME	Record name on SD Card
Type	Indicate type of record: General record.
Interval	General record recording interval (integration period)
Start	General record start time.
End	General record stop time.
Size	Record size in kilobytes (kB) or megabytes (MB).

Table 4.79: Keys in General record front page screen



VIEW

Switches to the CHANNELS SETUP menu screen.

Particular signal groups can be observed by pressing on F1 key (VIEW).

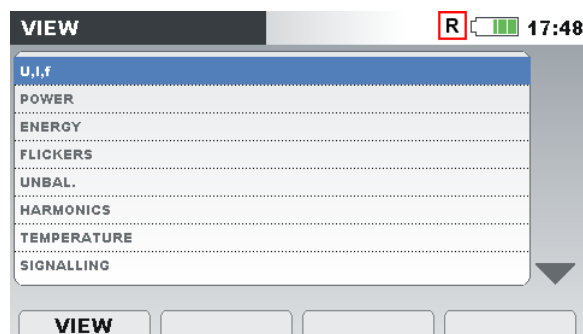





Keys in CHANNELS SETUP menu screen:



Selects particular signal group.



Enters particular signal group (TREND view).

		ESC	Exits to MEMORY LIST menu.
F2	CLEAR		Clears the last record. In order to clear complete memory, delete records one by one. Opens confirmation window for clearing all saved records.
F4	CLR ALL		Keys in confirmation window:
			Selects YES or NO.
			Confirms selection.
		ESC	Exits confirmation window without clearing saved records.
			Browses through records (next or previous record).
			Selects parameter (only in CHANNELS SETUP menu).
ESC			Returns to the "RECORDERS" submenu.

By pressing **F1 VIEW**, in CHANNELS SETUP menu, TREND graph of selected channel group will appear on the screen. Typical screen is shown on figure below.

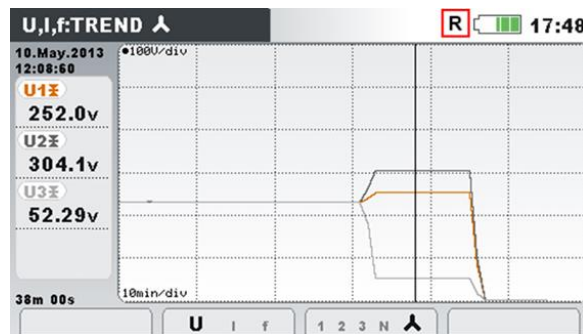

















Figure 4.64: Viewing recorder U,I,f TREND data

Table 4.80: Instrument screen symbols and abbreviations

	Memory list recall. Shown screen is recalled from memory.
	Indicates position of the cursor at the graph.
U1, U2, U3:	Maximal () , average () and minimal () recorded value of phase voltage U_{1Rms} , U_{2Rms} , U_{3Rms} , for time interval selected by cursor.
U12, U23, U31:	Maximal () , average () and minimal () recorded value of phase-to-phase voltage U_{12Rms} , U_{23Rms} , U_{31Rms} for time interval selected by cursor.
Ip:	Maximal () , average () and minimal () recorded value of current I_{1Rms} , I_{2Rms} , I_{3Rms} , I_{NRms} , for time interval selected by cursor.

38m 00s	Time position of cursor regarding to the record start time.
10.May.2013 12:08:50	Time clock at cursor position.

Table 4.81: Keys in Viewing recorder U,I,f TREND screens

		Selects between the following options:
	U I f U, I U/ I	Shows voltage trend.
	u I f U, I U/ I	Shows current trend.
	u I f U , I U/ I	Shows frequency trend.
	u I f U , I U / I	Shows voltage and current trends (single mode).
	u I f U, I U / I	Shows voltage and current trends (dual mode).
		Selects between phase, neutral, all-phases and view:
	1 2 3 N ^	Shows trend for phase L1.
	1 2 3 N ^	Shows trend for phase L2.
	1 2 3 N ^	Shows trend for phase L3.
	1 2 3 N ^	Shows trend for neutral channel.
	1 2 3 N ^	Shows all phases trends.
	12 23 31 Δ	Shows trend for phases L12.
	12 23 31 Δ	Shows trend for phases L23.
	12 23 31 Δ	Shows trend for phases L31.
	12 23 31 Δ	Shows all phase to phase trends.
	Moves cursor and select time interval (IP) for observation.	
	Returns to the "CHANNELS SETUP" menu screen.	

Note: Other recorded data (power, harmonics, etc.) has similar manipulation principle as described in previous sections of this manual.

4.20.2 Waveform snapshot

This type of record can be made by using  key (press and hold  key).

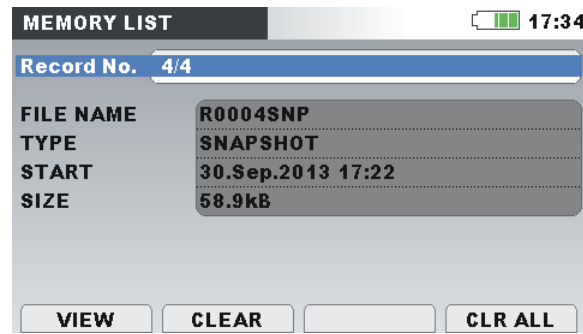

Figure 4.65: Front page of Snapshot in MEMORY LIST menu

Table 4.82: Recorder settings description

Record No.	Selected record number, for which details are shown.
FILE NAME	Record name on SD Card
Type	Indicate type of record: <ul style="list-style-type: none"> • Snapshot.
Start	Record start time.
Size	Record size in kilobytes (kB).

Table 4.83: Keys in Snapshot record front page screen

Switches to CHANNELS SETUP menu screen.

Particular signal group can be observed by pressing on F1 key (VIEW).

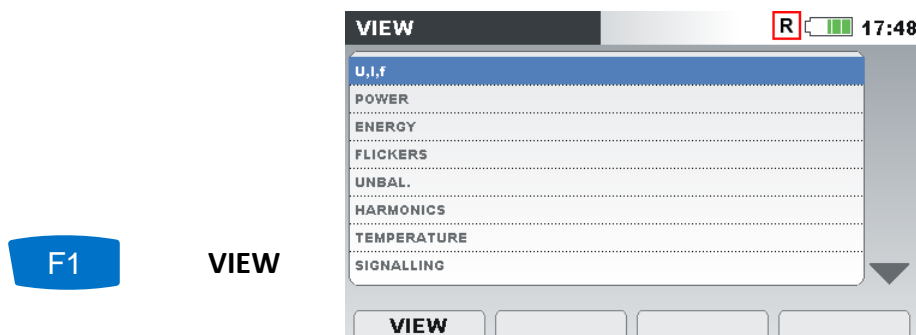

Keys in CHANNELS SETUP menu screen:



Selects particular signal group.



Enters particular signal group (METER or SCOPE view).



Exits to MEMORY LIST menu.







CLEAR

Clears the last record. In order to clear complete memory, delete records one by one.

Opens confirmation window for clearing all saved records.

Keys in confirmation window:

	CLR ALL		Selects YES or NO.
			Confirms selection.
			Exits confirmation window without clearing saved records.

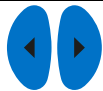

Browses through records (next or previous record).



Returns to the "RECORDERS" submenu.

By pressing  **VIEW** in CHANNELS SETUP menu METER screen will appear. Typical screen is shown on figure below.

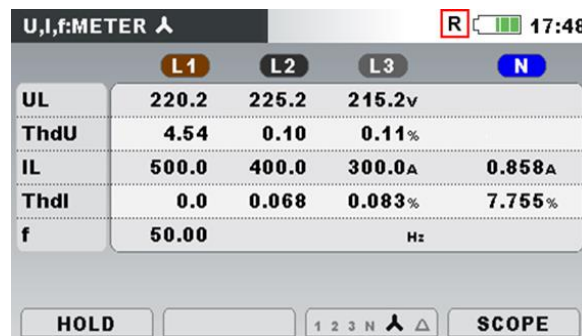

Figure 4.66: U,I,f meter screen in recalled snapshot record

Note: For more details regarding manipulation and data observing see previous sections of this manual.

Note: WAVEFORM SNAPSHOT is automatically created at the start of GENERAL RECORDER.

4.20.3 Waveform/inrush record (available at Energy Master XA)

This type of record is made by Waveform recorder. For details regarding manipulation and data observing see section Captured waveform 4.15.3.

4.20.4 Transients record (available at Energy Master XA)

This type of record is made by Transient recorder. For details regarding manipulation and data observing see section 4.16.3.

4.21 Measurement Setup submenu

From the "MEASUREMENT SETUP" submenu measurement parameters can be reviewed, configured and saved.

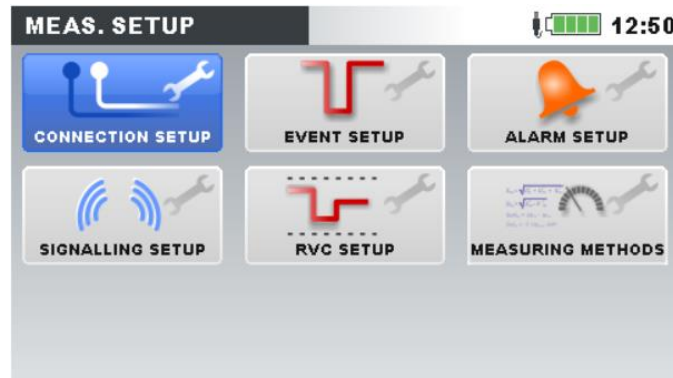
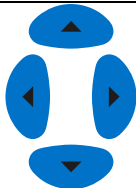



Figure 4.67: MEASUREMENT SETUP submenu

Table 4.84: Description of Measurement setup options

Connection setup	Setup measurement parameters.
Event setup	Setup event parameters.
Alarm setup	Setup alarm parameters.
Signalling setup	Setup signalling parameters.
RVC setup	Setup "Rapid voltage changes" (RVC) parameters.
Measuring methods	Selection of measurement method (Modern (IEEE 1459), Classic (Vector), Classic (Arithmetic)); Record Organisation and Recorded start Time.

Table 4.85: Keys in Measurement setup submenu screen

	Selects option from the "MEASUREMENT SETUP" submenu.
	Enters the selected option.
	Returns to the "MAIN MENU" screen.

4.21.1 Connection setup

In this menu user can setup connection parameters, such as nominal voltage, frequency, etc. After all parameters are provided, instrument will check if given parameters complies with measurements. In case of incompatibility instrument will show Connection check warning (X) before leaving menu.

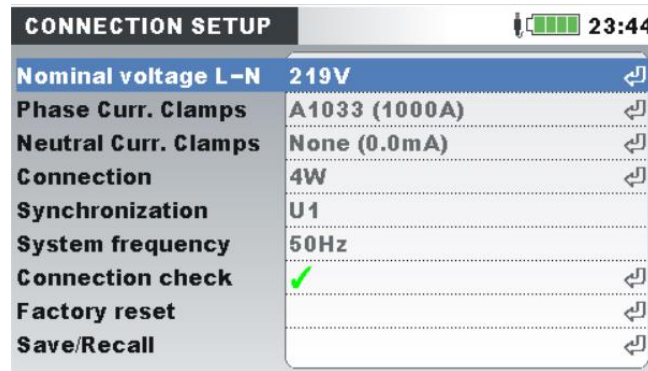
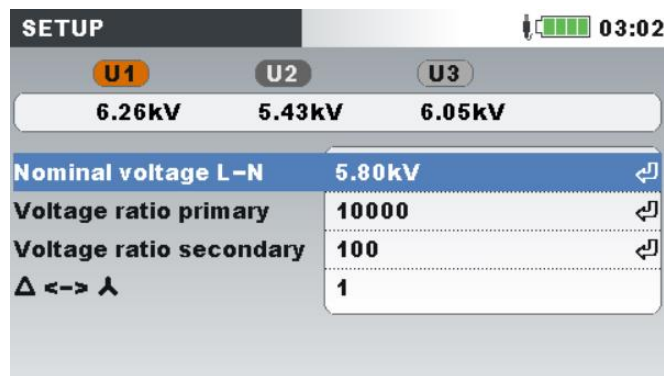

Figure 4.68: "CONNECTION SETUP" screen

Table 4.86: Description of Connection setup

Set nominal voltage. Select voltage according to the network voltage. If voltage is measured over potential transformer, then press ENTER for setting transformer parameters:



Nominal voltage

Voltage ratio: Potential transformer ratio $\Delta \leftrightarrow \lambda$:

Transformer type		Symbol	Additional transformer ratio
Primary	Secondary		
Delta	Star	$\Delta \rightarrow \lambda$	$1/\sqrt{3}$
Star	Delta	$\lambda \rightarrow \Delta$	$\sqrt{3}$
Star	Star	$\lambda \rightarrow \lambda$	1
Delta	Delta	$\Delta \rightarrow \Delta$	1

Note: Instrument can always measure accurately at up to 150% of selected nominal voltage.

Phase Curr. Clamps	Selects phase clamps for phase current measurements.
Neutral Curr. Clamps	

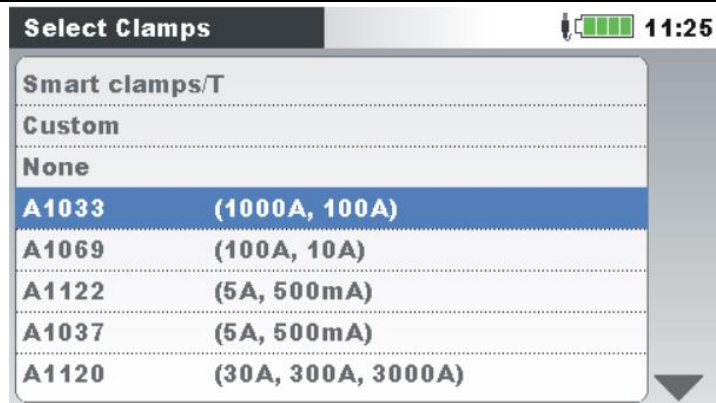

Note: For Smart clamps (A 1502, A 1227, A 1281, ...) always select "Smart clamps". Check in the Metrel General Catalogue, which clamps are developed as "Smart clamps")

Note: Use "None" option for voltage measurements only.

Note: See section 5.2.3 for details regarding further clamps settings.

Method of connecting the instrument to multi-phase systems (see 5.2.1 for details).

- **1W:** 1-phase 3-wire system;

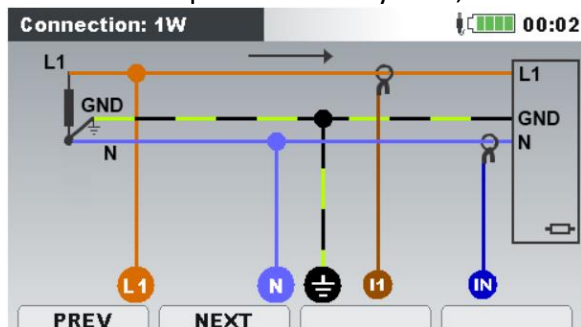

Connection

- **2W:** 2-phase 4-wire system;

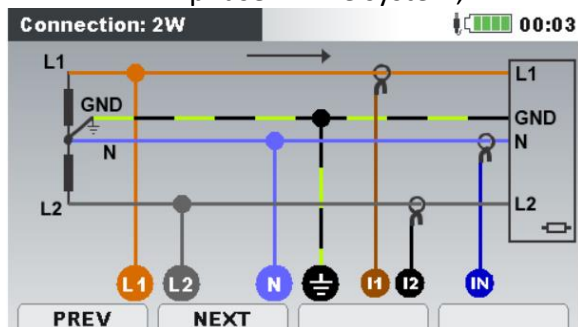

- **3W:** 3-phase 3-wire system;

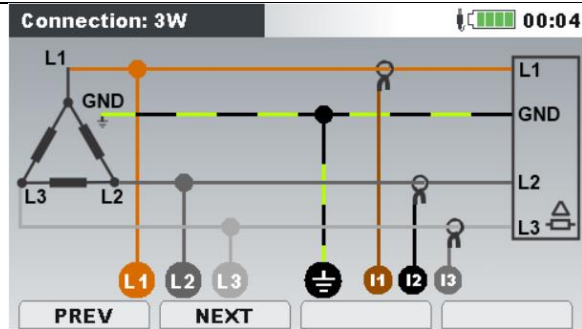

- **4W:** 3-phase 4-wire system;

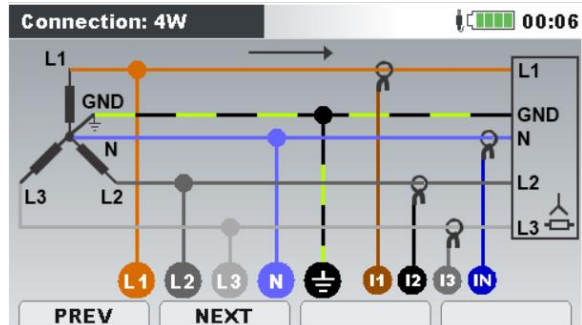

- **OpenD:** 3-phase 2-wire (Open Delta) system.

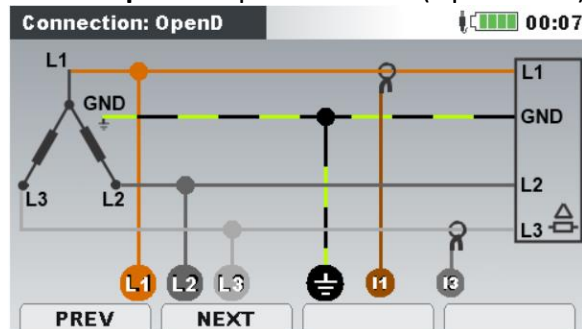

Synchronization

Synchronization channel. This channel is used for instrument synchronization to the network frequency. Also, a frequency measurement is performed on that channel. Depending on **Connection** user can select:



- **1W, 2W, 4W:** U1 or I1.
- **3W, OpenD:** U12, or I1.

System frequency

Select system frequency. According to this setting 10 or 12 cycle interval will be used for calculus (according to IEC 61000-4-30):

- 50 Hz – 10 cycle intervals
- 60 Hz – 12 cycle intervals

Check if measurement results comply with given limits.

Connection check  

Connection check is marked with green OK sign (✓) if instrument is connected properly and measurement comply with given measurement setup.

Connection check is marked with yellow OK sign (✓), indicate that some measurement is at the edge of instrument technical specification. This does not mean that something is necessary wrong, but require user attention to double check connection and instrument settings. Press F4 to check LIMITS.

Fail sign (✗) indicate that that instrument is connected incorrectly or measurement setup does not correspond with measured value. In this case it is necessary to readjust measurement settings, and check instrument connections.

By pressing ENTER key, detailed Connection check will be shown.

Connection check

Connection: Consumed		11:52		
	L1	L2	L3	N
U	✓ 230.1	✓ 229.9	✓ 230.3	v
I	✓ 100.5	✓ 100.6	✓ 100.6	1.861 A
P	22.35	22.35	22.38	kW
Phase	✓ -14.9	✓ -14.9	✓ -14.9	°
Useq	✓ 1 2 3	Ptot	67.08	kW
Iseq	✓ 1 2 3	f	✓ 49.996	Hz
CUR. DIR.		VIEW	AUTOSET I	LIMITS

See section 5.2.4 for details, how to use this menu.

Factory reset

Set factory default parameters. These are:
 Nominal voltage: 230V (L-N);
 Voltage ratio: 1:1;
 $\Delta \leftrightarrow \blacktriangle$: 1
 Phase current clamps: Smart Clamps;
 Neutral current clamps: None;
 Connection: 4W;
 Synchronization: U1
 System frequency: 50 Hz.
 Dip voltage: 90 % U_{Nom}
 Dip hysteresis: 2 % U_{Nom}
 Interrupt voltage: 5 % U_{Nom}
 Interrupt hysteresis: 2 % U_{Nom}
 Swell voltage: 110 % U_{Nom}
 Swell hysteresis: 2 % U_{Nom}
 Signalling frequency1: 316 Hz
 Signalling frequency2:1060 Hz
 Signalling record duration: 10 sec
 Signalling threshold: 5 % of nominal voltage
 RVC threshold: 3 % of nominal voltage
 RVC hysteresis: 25 % of RVC threshold
 Clear Alarm setup table

Save/Recall

Save connection settings to SD card under specific name
 Recall connection settings from the SD card

No	Conn. Settings	Unom	Clamp	Freq.	Connection
1	CONN000.PAR	>990kV	1000A	50Hz	4W
2	CONN001.PAR	1.00kV	1000A	50Hz	4W

SAVE RECALL CLEAR

Table 4.87: Keys in Connection setup menu

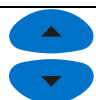

Selects Connection setup parameter to be modified.



Changes selected parameter value.



Enters into submenu.
 Confirms Factory reset.

Depends from Connection check status.

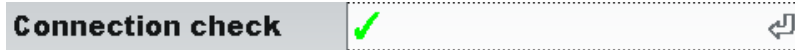

For:



- OK sign (✓, ✓) Returns to the “MEASUREMENT SETUP” submenu.
- Fail sign (✗) enter into “CONNECTION CHECK” submenu. It is expected that user will resolve this issue before continuing with measurements. Press **ESC** again in order to leave “CONNECTION CHECK” menu.

4.21.2 Event setup

In this menu user can setup voltage events and their parameters. See 6.1.12 for further details regarding measurement methods. Captured events can be observed through EVENTS TABLE screen. See 4.17 and 6.1.12 for details.

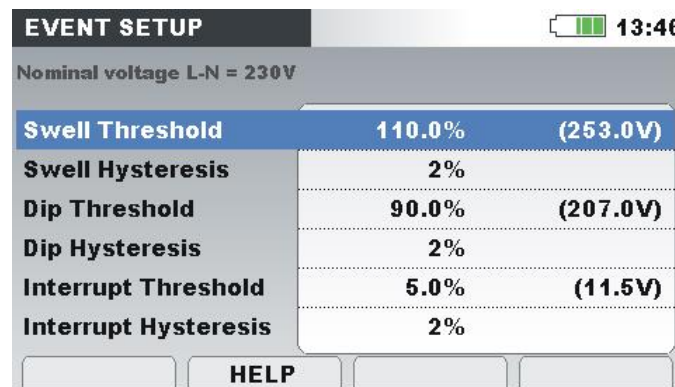

Figure 4.69: Event setup screen

Table 4.88: Description of Event setup

Nominal voltage	Indication of type (L-N or L-L) and value of nominal voltage.
Swell Threshold	Set swell threshold value in % of nominal voltage.
Swell Hysteresis	Set swell hysteresis value in % of nominal voltage.
Dip Threshold	Set dip threshold value in % of nominal voltage.
Dip Hysteresis	Set dip hysteresis value in in % of nominal voltage.
Interrupt Threshold	Set interrupt threshold value in % of nominal voltage.
Interrupt Hysteresis	Set interrupt hysteresis in % of nominal voltage.

Table 4.89: Keys in Event setup screen

F2	HELP	Shows help screens for Dip, Swell and Interrupt. See 6.1.13 for details.
-----------	-------------	--

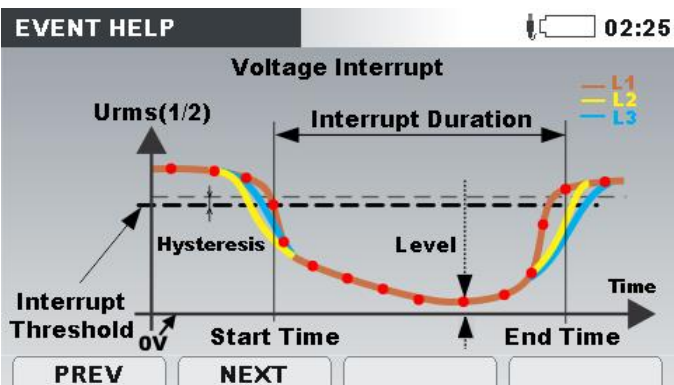
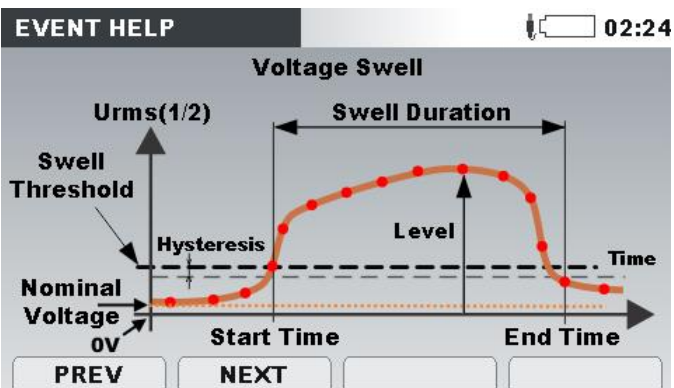
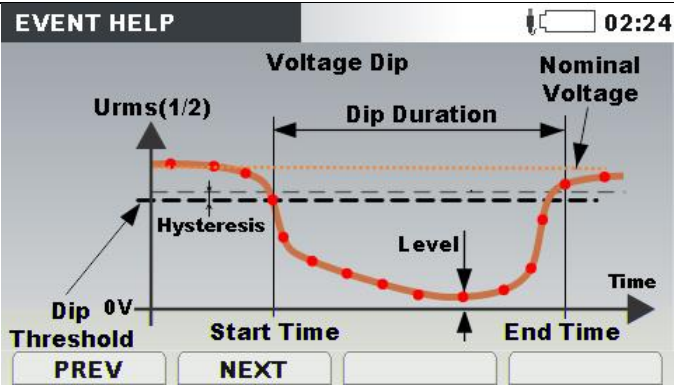

Keys in CHANNELS SETUP menu screen:

- F1 **PREV** Previous help screen
- F2 **NEXT** Next help screen
- ◀
▶
 Move between help screens.
- ENTER Move back to EVENT SETUP screen
- ESC



Selects Voltage events setup parameter to be modified.



Changes selected parameter value.



Returns to the "MEASUREMENT SETUP" submenu.

4.21.3 Alarm setup

Up to 10 different alarms, based on any measurement quantity which is measured by instrument, can be defined. See 6.1.14 for further details regarding measurement methods. Captured events can be observed through ALARMS TABLE screens. See 4.18 and 6.1.14 for details.

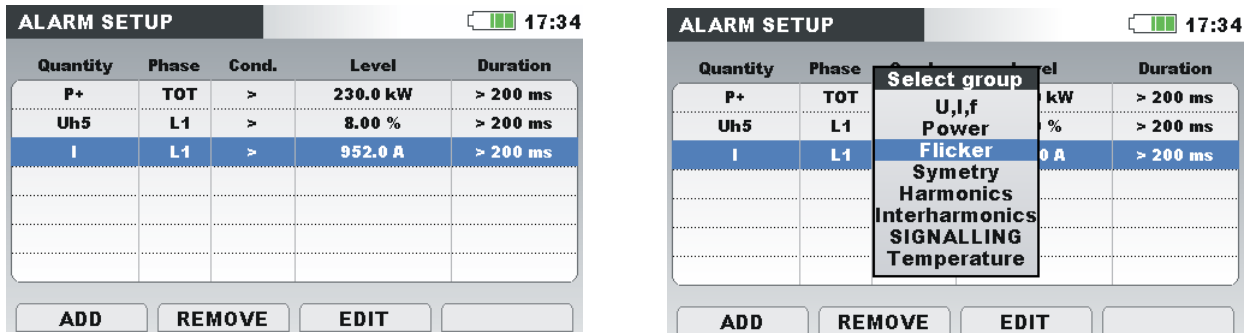

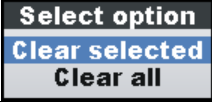

Figure 4.70: Alarm setup screens

Table 4.90: Description of Alarm setup

<p>1st column - Quantity (P+, Uh5, I, on figure above)</p>	<p>Select alarm from measurement group and then measurement itself.</p> <div style="display: flex; justify-content: space-around; align-items: center;"> <div style="border: 1px solid black; padding: 2px;"> <p>Select group</p> <p>U,I,f</p> <p>Power</p> <p>Flicker</p> <p>Symetry</p> <p>Harmonics</p> <p>Interharmonics</p> <p>SIGNALLING</p> <p>Temperature</p> </div> <div style="border: 1px solid black; padding: 2px;"> <p>Select quantity</p> <p>Pstmin</p> <p>Pst</p> <p>PIt</p> </div> </div>
<p>2nd column - Phase (TOT, L1, on figure above)</p>	<p>Select phases for alarms capturing</p> <ul style="list-style-type: none"> • L1 – alarms on phase L₁; • L2 – alarms on phase L₂; • L3 – alarms on phase L₃; • LN – alarms on phase N; • L12 – alarms on line L₁₂; • L23 – alarms on line L₂₃; • L31 – alarm on line L₃₁; • ALL – alarms on any phase; • TOT – alarms on power totals or non-phase measurements (frequency, unbalance).
<p>3rd column - Condition (">" on figure above)</p>	<p>Select triggering method: < trigger when measured quantity is lower than threshold (FALL); > trigger when measured quantity is higher than threshold (RISE);</p>
<p>4th column - Level</p>	<p>Threshold value.</p>
<p>5th column - Duration</p>	<p>Minimal alarm duration. Triggers only if threshold is crossed for a defined period of time.</p>

Note: It is recommended that for flicker measurement, recorder is set to 10 min.

Table 4.91: Keys in Alarm setup screens

F1	ADD	Adds new alarm.
F2	REMOVE	Clears selected or all alarms: 
F3	EDIT	Edits selected alarm.
ENTER		Enters or exits a submenu to set an alarm.
		Cursor keys. Selects parameter or changes value.
		Cursor keys. Selects parameter or changes value.
ESC		Confirms setting of an alarm. Returns to the "MEASUREMENT SETUP" submenu.

4.21.4 Signalling setup

Mains signalling voltage, called "ripple control signal" in certain applications, is a burst of signals, often applied at a non-harmonic frequency, that remotely control industrial equipment, revenue meters, and other devices.

Two different signalling frequencies can be defined. Signals can be used as a source for the user defined alarm and can also be included in recording. See section 4.21.3 for details how to set-up alarms. See section 4.14 for instructions how to start recording.

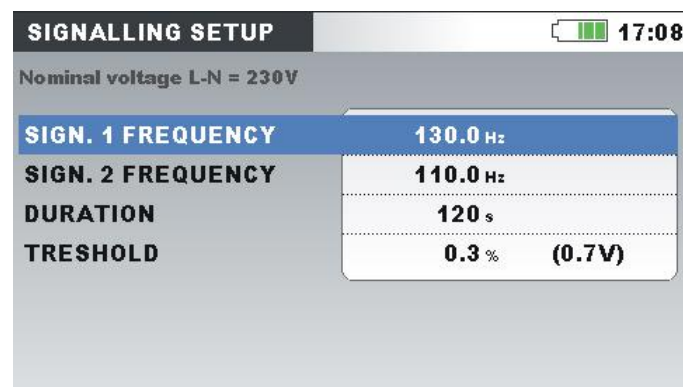





Figure 4.71: Signalling setup screen

Table 4.92: Description of Signalling setup

Nominal voltage	Indication of type (L-N or L-L) and value of nominal voltage.
SIGN. 1 FREQUENCY	1 st observed signalling frequency.

SIGN. 2 FREQUENCY	2 nd observed signalling frequency.
DURATION	Duration of RMS record, which will be captured after threshold value is reached.
THRESHOLD	Threshold value expressed in % of nominal voltage, which will trigger recording of signalling event.

Table 4.93: Keys in Signalling setup screen

	Enters or exits a submenu to set signalling frequency.
	Toggles between given parameters.
	Changes selected parameter.
	Returns to the "MEASUREMENT SETUP" submenu.

4.21.5 Rapid voltage changes (RVC) setup

RVC is a quick transition in RMS voltage occurring between two steady-state conditions, and during which the RMS voltage does not exceed the dip/swell thresholds.

A voltage is in a steady-state condition if all the immediately preceding 100/120 $U_{Rms(\frac{1}{2})}$ values remain within a set RVC threshold from the arithmetic mean of those 100/120 $U_{Rms(\frac{1}{2})}$ (100 values for 50 Hz nominal and 120 values for 60 Hz). The RVC threshold is set by the user according to the application, as a percentage of U_{Nom} , within 1 ÷ 6 %. See section 6.1.15 for details regarding RVC measurement. See section 4.14 for instructions how to start recording.





Figure 4.72: RVC setup screen

Table 4.94: Description of RVC setup

Nominal voltage	Indication of type (L-N or L-L) and value of nominal voltage.
RVC THRESHOLD	RVC threshold value expressed in % of nominal voltage for steady state voltage detection.
RVC HYSTERESIS	RVC hysteresis value expressed in % of RVC threshold.

Table 4.95: Keys in RVC setup screen

	Toggles between given parameters.
	Changes selected parameter.
	Returns to the "MEASUREMENT SETUP" submenu.

4.21.6 Measuring Methods setup

In this menu different measurement methods can be selected, according to the local standards and practice. Please note that instrument record all measurement (Classic and Modern), regardless of selected method.

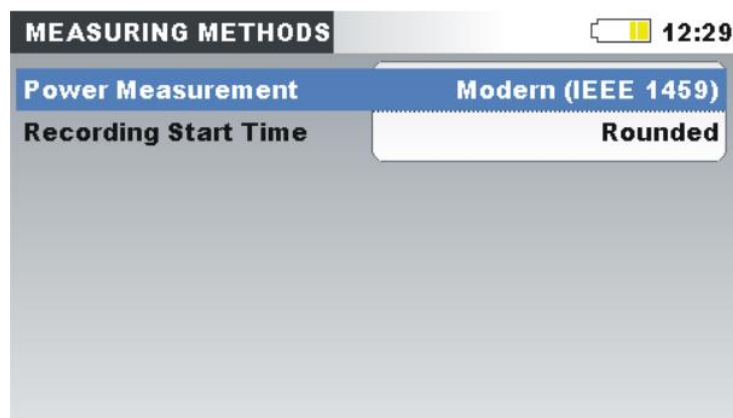





Figure 4.73: Measuring Methods setup screen

Table 4.96: Description of Measuring Methods setup

Power Measurements	<p>Modern (IEEE 1459) measuring method. See section 6.1.5 for details.</p> <p>Classic (Vector) measuring method. See section 6.1.6 for details.</p> <p>Classic (Arithmetic) measuring method. See section 6.1.6 for details.</p>
Recording Start Time	<p>Rounded: recorder start time synchronized with real time (integer number of recorder period in one hour/day).</p> <p>Immediately: recorder starts immediately or the first subsequent minute.</p>

Table 4.97: Keys in Measuring Methods setup screen

	Toggles between given parameters.
	Changes selected parameter.
	Returns to the "MEASUREMENT SETUP" submenu.

4.22 General Setup submenu

From the “GENERAL SETUP” submenu communication parameters, real clock time, language can be reviewed, configured and saved.

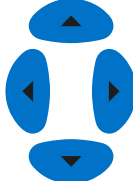



Figure 4.74: GENERAL SETUP submenu

Table 4.98: Description of General setup options

Time & Date	Set time, date and time zone.
Language	Select language.
Instrument info	Information about the instrument.
Lock/Unlock	Lock instrument to prevent unauthorized access.
Colour Model	Select colours for displaying phase measurements.

Table 4.99: Keys in General setup submenu

	Selects option from the “GENERAL SETUP” submenu.
	Enters the selected option.
	Returns to the “MAIN MENU” screen.

4.22.1 Time & Date

Time, date and time zone can be set in this menu.

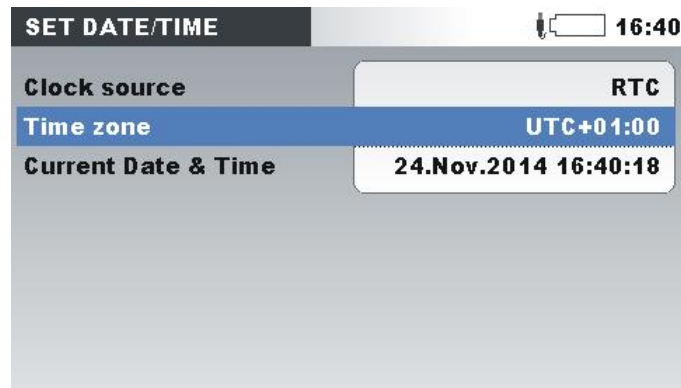

Figure 4.75: Set date/time screen

Table 4.100: Description of Set date/time screen





Clock source	Show clock source: RTC – internal real time clock
Time zone	Selects time zone.
Current Time & Date	Show/edit current time and date 

Table 4.101: Keys in Set date/time screen

	Selects parameter to be changed.
	Modifies parameter. Selects between the following parameters: hour, minute, second, day, month or year.
	Enters Date/time edit window.
	Returns to the “GENERAL SETUP” submenu.

4.22.2 Language

Different languages can be selected in this menu.

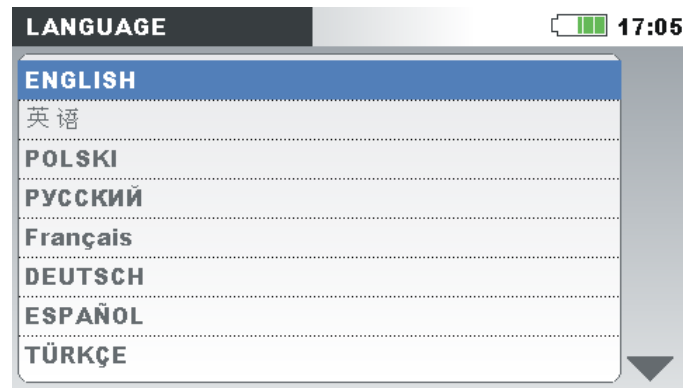





Figure 4.76: Language setup screen

Table 4.102: Keys in Language setup screen

	Selects language.
	Confirms the selected language.
	Returns to the "GENERAL SETUP" submenu.

4.22.3 Instrument info

Basic information concerning the instrument (company, user data, serial number, firmware version and hardware version) can be viewed in this menu.

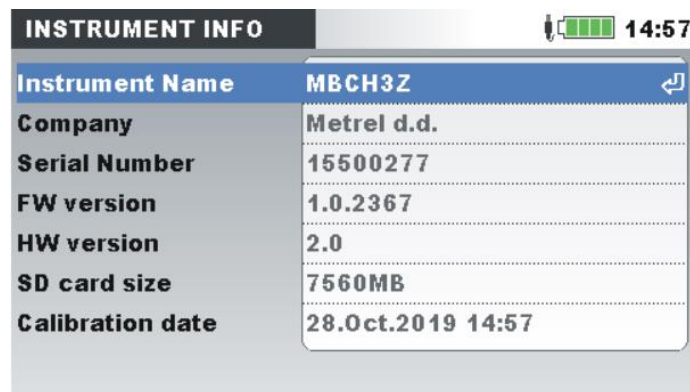

Figure 4.77: Instrument info screen

Table 4.103: Keys in Instrument info screen

	Returns to the "GENERAL SETUP" submenu.
---	---

4.22.4 Lock/Unlock

Energy Master XA/Energy Master has the ability to prevent unauthorized access to all important instrument functionality by simply locking the instrument. If instrument is left for a longer period at an unsupervised measurement spot, it is recommended to prevent unintentional stopping of record, instrument or measurement setup modifications, etc. Although instrument lock prevents

Unauthorized changing of instrument working mode, it does not prevent non-destructive operations as displaying current measurement values or trends. User locks the instrument by entering secret lock code in the Lock/Unlock screen.

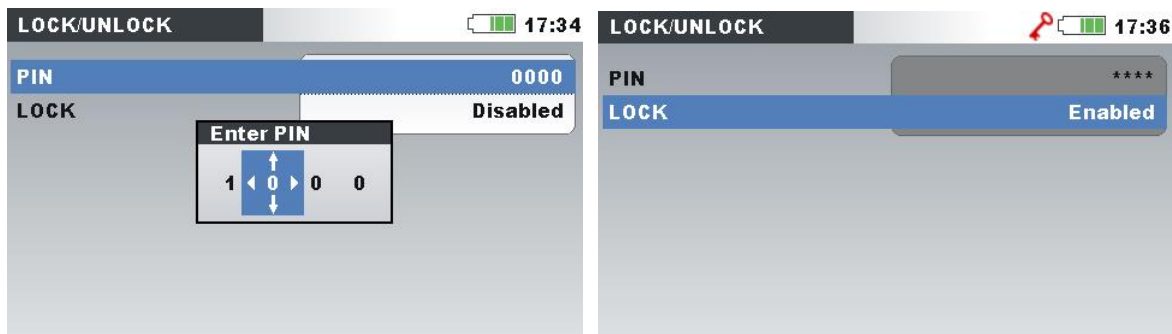







Figure 4.78: Lock/Unlock screen

Table 4.104: Description of Lock/Unlock screen

Pin	<p>Four-digit numeric code used for Locking/Unlocking the instrument.</p> <p>Press ENTER key for changing the Pin code. “Enter PIN” window will appear on screen.</p> <p>Note: Pin code is hidden (****), if the instrument is locked.</p>
Lock	<p>The following options for locking the instrument are available:</p> <ul style="list-style-type: none"> • Disabled • Enabled

Table 4.105: Keys in Lock/Unlock screen

	Selects parameter to be modified.
	Change value of the selected digit in Enter pin window.
	<p>Selects digit in Enter pin window.</p> <p>Locks the instrument.</p> <p>Opens Enter pin window for unlocking.</p>
	<p>Opens Enter pin window for pin modification.</p> <p>Accepts new pin.</p> <p>Unlocks the instrument (if pin code is correct).</p>
	Returns to the “GENERAL SETUP” submenu.

Following table shows how locking impacts instrument functionality.

Table 4.106: Locked instrument functionality

MEASUREMENTS	<p>Allowed access.</p> <p>Waveform snapshot functionality is blocked.</p>
RECORDERS	No access.
MEASUREMENT SETUP	No access.

GENERAL SETUP

No access except to Lock/Unlock menu.

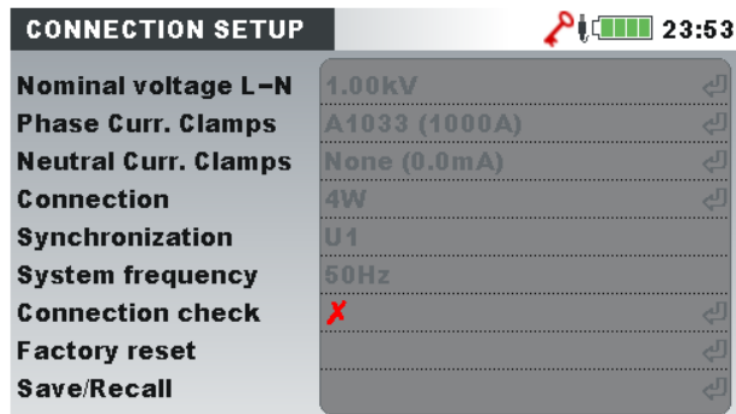

Figure 4.79: Locked instrument screen

Note: In case user forget unlock code, general unlock code “7350” can be used to unlock the instrument.

4.22.5 Colour model

In COLOUR MODEL menu, user can change colour representation of phase voltages and currents, according to the customer needs. There are some predefined colour schemes (EU, USA, etc.) and a custom mode where user can set up its own colour model.

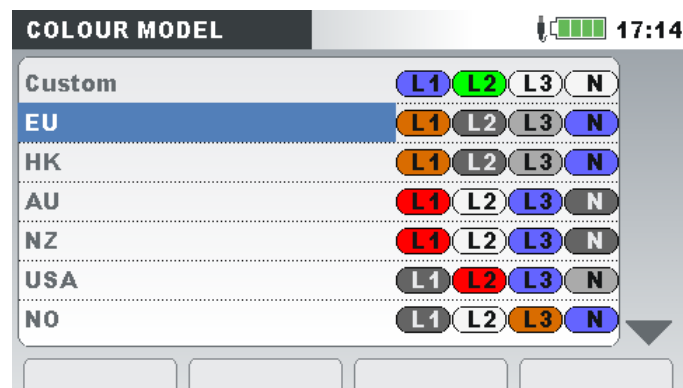
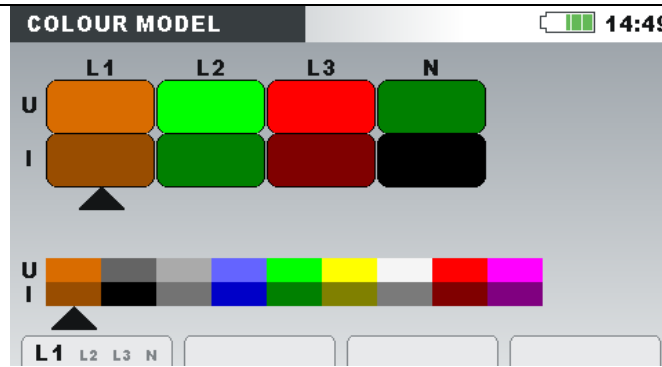

Figure 4.80: Colour representation of phase voltages





Table 4.107: Keys in Colour model screens

**EDIT**

Opens edit colour screen (only available in custom model).



Keys in Edit colour screen:

	L1 L2 L3 N	Shows selected colour for phase L1.
	L1 L2 L3 N	Shows selected colour for phase L2.
	L1 L2 L3 N	Shows selected colour for phase L3.
	L1 L2 L3 N	Shows selected colour for neutral channel N.
		Selects colour.
		Returns to the "COLOUR MODEL" screen.
		

 Selects Colour scheme.

 Confirms selection of Colour scheme and returns to the "GENERAL SETUP" submenu.

 Returns to the "GENERAL SETUP" submenu without modifications.

4.22.6 Backlight

In BACKLIGHT menu, user can define if LCD will be switched OFF automatically after predefined time.

LCD is switched OFF in two steps:

- LCD dimmer timer
- LCD OFF timer (followed by LCD dimmer timer)

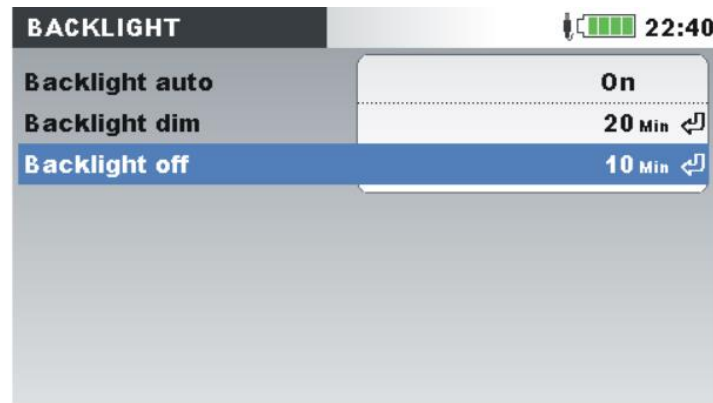





Figure 4.81: Backlight screen options

Table 4.108: Description Backlight screen

Backlight auto	ON – Enabling LCD dimmer and off function OFF – Disabling LCD dimmer and off function
Backlight dimm	Timer after which the LCD is dimmed (OFF, 1 120 min)
Backlight off	Timer after which the LCD is turned OFF (after activation of Backlight dim) (OFF, 1 120 min)

Table 4.109: Keys in Backlight screen

	Selects parameter.
	Selects parameter.
	Entering into selected parameter / confirms parameter.
	Returns to the “GENERAL SETUP” submenu.

5 Recording Practice and Instrument Connection

In following section recommended measurement and recording practice is described.

5.1 Measurement campaign

Power quality measurements are specific type of measurements, which can last many days, and mostly they are *performed* only once. Usually recording campaign is performed to:

- Statistically analyse some points in the network.
- Troubleshoot malfunctioning device or machine.

Since measurements are mostly *performed* only once, it is very important to properly set measuring equipment. Measuring with wrong settings can lead to false or useless measurement results. Therefore, instrument and user should be fully prepared before measurement begins.

In this section recommended recorder procedure is shown. We recommend to strictly follow guidelines in order to avoid common problems and measurement mistakes. Figure below shortly summarizes recommended measurement practice. Each step is then described in details.

Note: PC software PowerView v3.0 has the ability to correct (after measurement is done):

- wrong real-time settings,
- wrong current and voltage scaling factors.

False instrument connection (messed wiring, opposite clamp direction), can't be fixed afterwards.

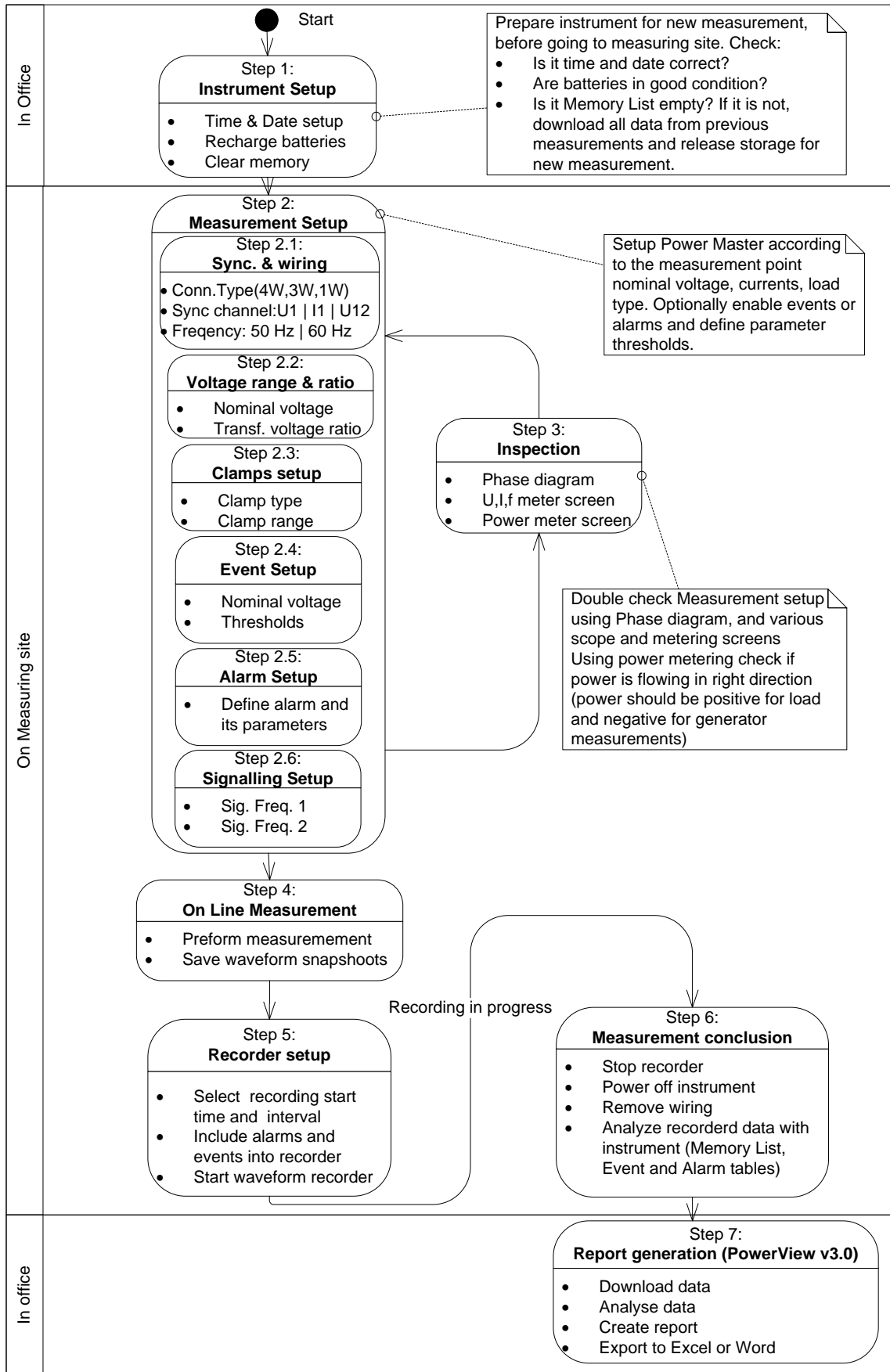

Figure 5.1: Recommended measurement practice

5.1.1.1 Step 1: Instrument setup

On site measurements can be very stressful, and therefore it is good practice to prepare measurement equipment in an office. Preparation of Energy Master XA/Energy Master include following steps:

- Visually check instrument and accessories.
Warning: Don't use visually damaged equipment!
- Always use batteries that are in good condition and fully charge them before you leave an office.
Note: In problematic PQ environment where dips and interrupts frequently occur instrument power supply fully depends on batteries! Keep your batteries in good condition.
- Download all previous records from instrument and clear the memory. (See section 4.19 for instruction regarding memory clearing).
- Set instrument time and date. (See section 4.22.1 for instruction regarding time and date settings).

5.1.1.2 Step 2: Measurement setup

Measurement setup adjustment is *performed* on measured site, after we find out details regarding nominal voltage, currents, type of wiring etc.

5.1.1.3 Step 2.1: Synchronization and wiring

- Connect current clamps and voltage tips to the "Device under measurement" (See section 5.2 for details).
- Select proper type of connection in "Connection setup" menu (See section 4.21.1 for details).
- Select synchronization channel. Synchronization to voltage is recommended, unless measurement is performed on highly distorted loads, such as PWM drives. In that case current synchronization can be more appropriate. (See section 4.21.1 for details).
- Select System frequency. System frequency is default mains system frequency. Setting this parameter is recommended if to measure signalling or flickers.

5.1.1.4 Step 2.2: Nominal voltage and ratio

- Select instrument nominal voltage according to the network nominal voltage.
Note: For 4W and 1W measurement all voltages are specified as phase-to-neutral (L-N). For 3W and Open Delta measurements all voltages are specifies as phase-to-phase (L-L).
Note: Instrument assures proper measurement up to 150 % of chosen nominal voltage.
- In case of indirect voltage measurement, select appropriate "Voltage ratio" parameters, according to transducer ratio. (See section 4.21.1 and 5.2.2 for details).

5.1.1.5 Step 2.3: Current clamps setup

- Using "Select Clamps" menu, select proper Phase and Neutral channel current clamps (see sections 4.21.1 for details).

- Select proper clamps parameters according to the type of connection (see section 5.2.3 for details).

5.1.1.6 Step 2.4: Event setup

Select threshold values for: swell, dip and interrupts (see sections 4.21.2 and 4.17 for details).

5.1.1.7 Step 2.5: Alarm setup

Use this step if you would like only to check if some quantities cross some predefined boundaries (see sections 4.18 and 4.21.3 for details).

5.1.1.8 Step 2.6: Signalling setup

Use this step only if you are interested in measuring mains signalling voltage. See section 4.21.4 for details.

5.1.1.9 Step 3: Inspection

After setup instrument and measurement is finished, user need to re-check if everything is connected and configured properly. Following steps are recommended:

- Using PHASE DIAGRAM menu check if voltage and current phase sequence is right regarding to the system. Additionally, check if current has right direction.
- Using U, I, f menu check if voltage and current have proper values.
- Check voltage and current THD.
Note: Excessive THD can indicate that too small range was chosen!
Note: In case of AD converter overvoltage or overloading current, icon  will be displayed.
- Using POWER menu check signs and indices of active, nonactive, apparent power and power factor.

If any of these steps give you suspicious measurement results, return to Step 2 and double check measurement setup parameters.

5.1.1.10 Step 4: On-line measurement

Instrument is now ready for measurement. Observe on line parameters of voltage, current, power, harmonics, etc. according to the measurement protocol or customer demands.

Note: Use waveform snapshots  to capture important measurement. Waveform snapshot capture all power quality signatures at once (voltage, current, power, harmonics, flickers).

5.1.1.11 Step 5: Recorder setup and recording

Using GENERAL RECORDER menu select type of recording and configure recording parameters such as:

- Time for data aggregation (Integration Period)
- Include events and alarms capture if necessary
Note: Waveform capturing available only for Energy Master XA

- Recording start time (optional)
- After setting recorder, recording can be started. (see section 4.14 for recorder details).

Note: Available memory status in Recorder setup should be checked before starting recording. Max. recording duration and max. number of records are automatically calculated according to recorder setup and memory size.

Note: Recording usually last few days. Assure that instrument during recording session is not reachable to the unauthorized persons. If necessary, use LOCK functionality described in section 4.22.4.

Note: If during record session instrument batteries are drained, due to long interruption for example, instrument will shut down. After electricity comes back, instrument will automatically start new recording session.

5.1.1.12 Step 6: Measurement conclusion

Before leaving measurement site we need to:

- Preliminary evaluate recorded data using TREND screens.
- Stop recorder.
- Assure that we record and measure everything we needed.

5.1.1.13 Step 7: Report generation (PowerView v3.0)

Download records using PC software PowerView v3.0 perform analysis and create reports. See PowerView v3.0 manual for details.

5.2 Connection setup

5.2.1 Connection to the LV Power Systems

This instrument can be connected to the 3-phase and single-phase network.

The actual connection scheme has to be defined in CONNECTION SETUP menu (see Figure below).

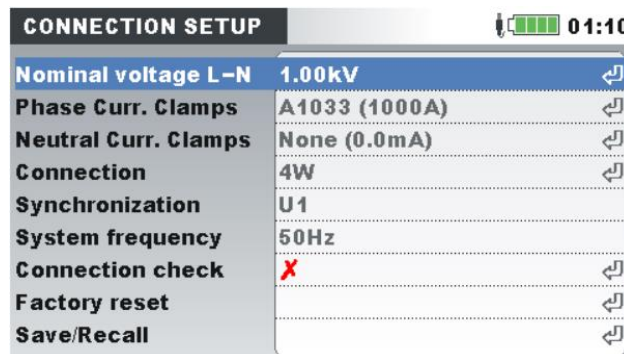

Figure 5.2: Connection setup menu

When connecting the instrument, it is essential that both current and voltage connections are correct. In particular the following rules have to be observed:

Clamp-on current clamp-on transformers

- The arrow marked on the clamp-on current transformer should point in the direction of current flow, from supply to load.
- If the clamp-on current transformer is connected in reverse the measured power in that phase would normally appear negative.

Phase relationships

- The clamp-on current transformer connected to current input connector I₁ has to measure the current in the phase line to which the voltage probe from L₁ is connected.

5.2.1.1 3-phase 4-wire system

In order to select this connection scheme, choose following connection on the instrument:

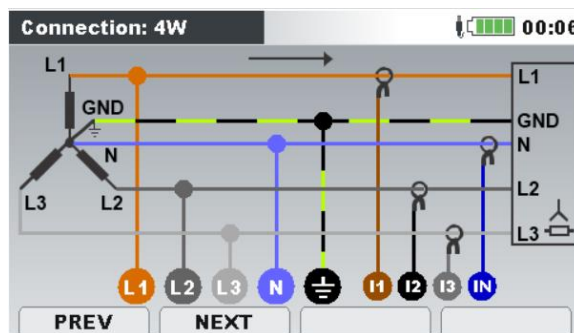

Figure 5.3: Choosing 3-phase 4-wire system on instrument

Instrument should be connected to the network according to figure below:

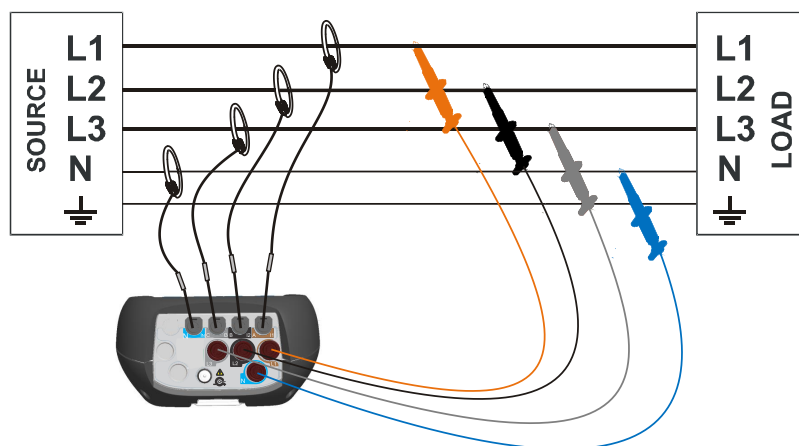

Figure 5.4: 3-phase 4-wire system

5.2.1.2 3-phase 3-wire system

In order to select this connection scheme, choose following connection on the instrument:

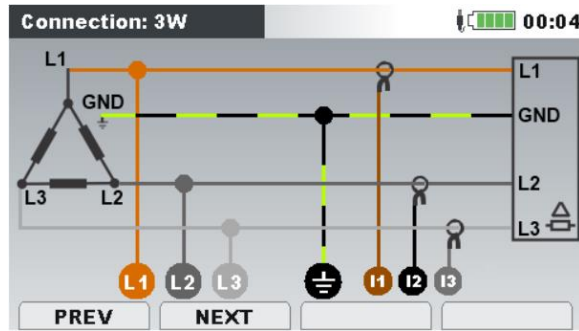

Figure 5.5: Choosing 3-phase 3-wire system on instrument

Instrument should be connected to the network according to figure below.

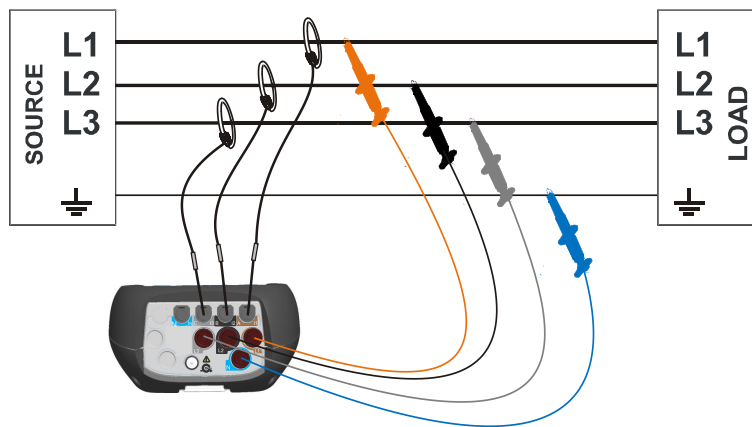

Figure 5.6: 3-phase 3-wire system

5.2.1.3 Open Delta (Aaron) 3-wire system

In order to select this connection scheme, choose following connection on the instrument:

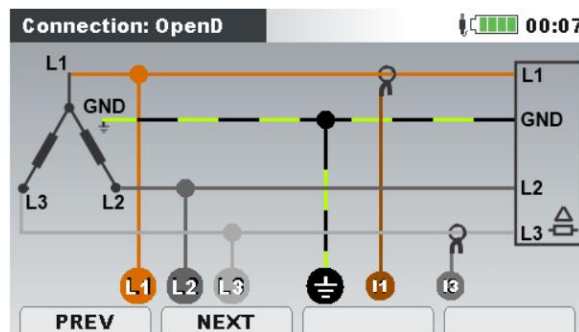

Figure 5.7: Choosing Open Delta (Aaron) 3-wire system on instrument

Instrument should be connected to the network according to figure below.

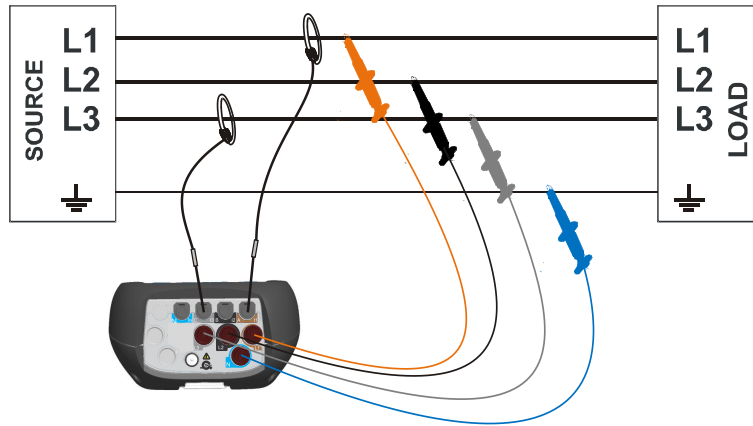

Figure 5.8: Open Delta (Aaron) 3-wire system

5.2.1.4 1-phase 3-wire system

In order to select this connection scheme, choose following connection on the instrument:

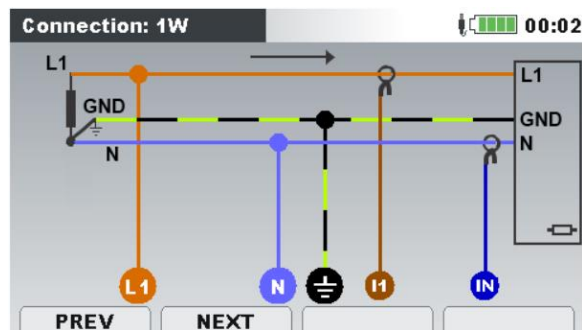

Figure 5.9: Choosing 1-phase 3-wire system on instrument

Instrument should be connected to the network according to figure below.

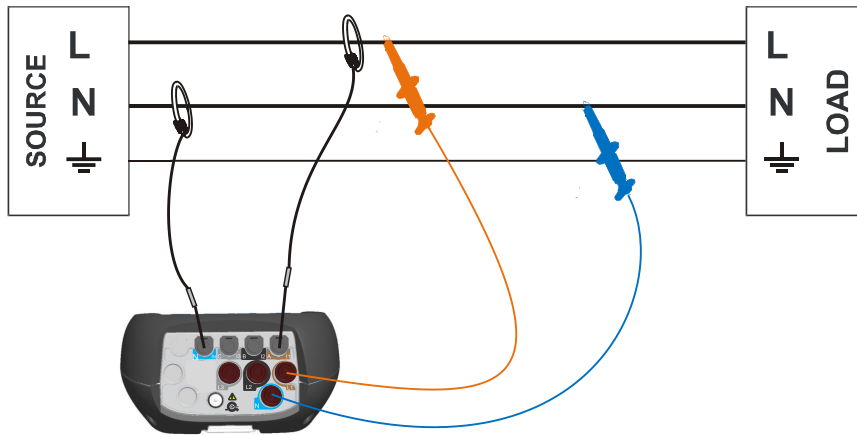

Figure 5.10: 1-phase 3-wire system

Note: In case of events capturing, it is recommended to connect unused voltage terminals to N voltage terminal.

5.2.1.5 2-phase 4-wire system

In order to select this connection scheme, choose following connection on the instrument:

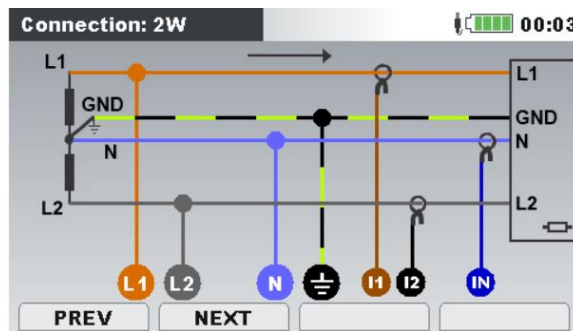

Figure 5.11: Choosing 2-phase 4-wire system on instrument

Instrument should be connected to the network according to figure below.

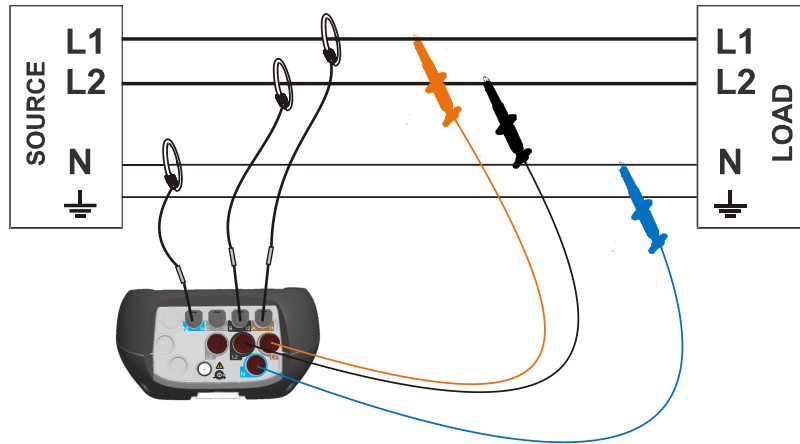

Figure 5.12: 2-phase 4-wire system

Note: In case of events capturing, it is recommended to connect unused voltage terminal to N voltage terminal.

5.2.2 Connection to the MV or HV Power System

In systems where voltage is measured at the secondary side of a voltage transformer (say 11 kV / 110 V), the voltage transformer ratio should be entered first. Afterward nominal voltage can be set to ensure correct measurement. In the next figure settings for this particular example is shown. See 4.21.1 for details.

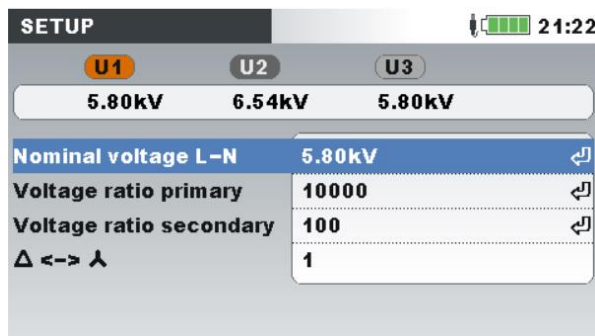

Figure 5.13: Voltage ratio for 10 kV / 100 V transformer example

Instrument should be connected to the network according to figure below.

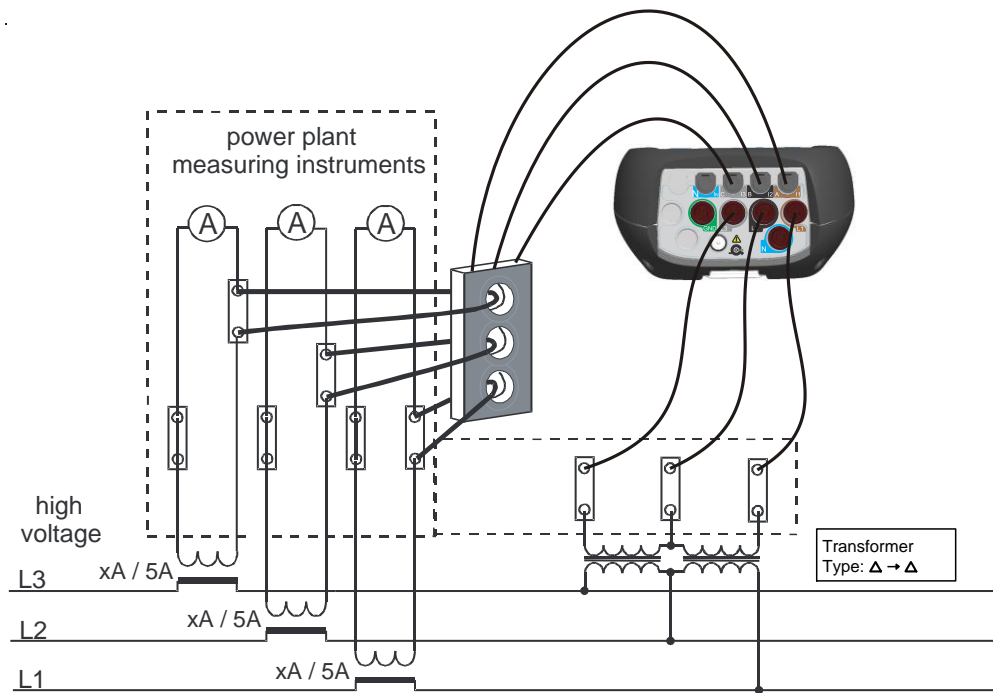

Figure 5.14: Connecting instrument to the existing current transformers in medium voltage system

5.2.3 Current clamp selection and transformation ratio setting

Clamp selection can be explained by two typical use cases: **direct current measurement** and **indirect current measurement**. In next section recommended practice for both cases is shown.

5.2.3.1 Auto range current clamp operation

Most of Metrel current clamps are developed as Smart clamps. They are automatically recognised by the instrument. Most of clamps support more different current ranges, for example 30/300/3000 A (Current clamps A 1501/A 1502/A 1227/A 1445/A 1582). Power Quality Instrument could operate in so called “Auto” range, where instrument automatically select the most optimal current clamp range. In this case, the most accurate current measurements are guaranteed.

Note 1: In case of “auto range” selection, Inrush measurements are not reliable.

Note 2: In case of “auto range” selection, synchronisation could not be selected to current.

Note 3: Current clamps with external current range (range selection on the clamps itself) selection does not support “auto range”.

Note 4: Current clamp needs specific time during current range changing to stabilize the readings (stabilization time is bigger for flex than for iron clamps). During stabilization time, current values are not presented (for the registration periods, shorter than 1 minute).

Note 5: During the ranging of current clamps ($I_1/I_2/I_3$ or I_n) energy and demand is not measured; so the total amount of energy/demand for these interval does not correspond the real consumed/generated energy/demand. There may be a difference for these intervals between energy measurements and energy calculated from demand measurements due to different

algorithms for phase/total energy/demand calculation depends on ranging of I1/I2/I3 or In current channel.

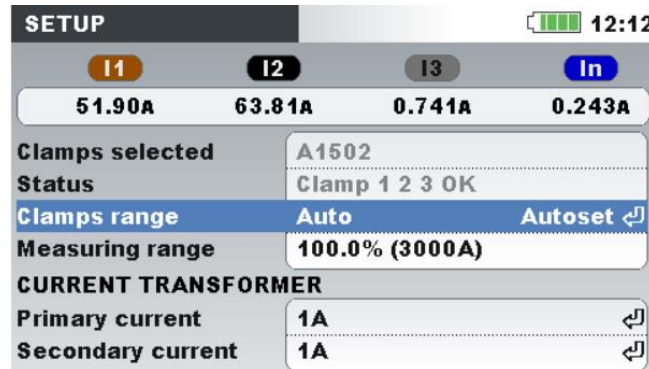

Figure 5.15: Smart current clamps auto range selection

5.2.3.2 Direct current measurement with clamp-on current transformer

In this type of measurement load/generator current is measured directly with one of clap-on current transformer. Current to voltage conversion is *performed directly* by the clamps. Direct current measurement can be *performed* by any clamp-on current transformer. We particularly recommend Smart clamps: flex clamps A 1502, A1227 and iron clamps A1281, A 1588 for example. Also, other Metrel clamp models A1783 (200 A), A1069 (100 A), etc. can be used. For more details about the current clamps, please check the Metrel’s General catalogue.

In the case of large loads there can be few parallel feeders which can’t be embraced by single clamps. In this case we can measure current only through one feeder as shown on figure below.

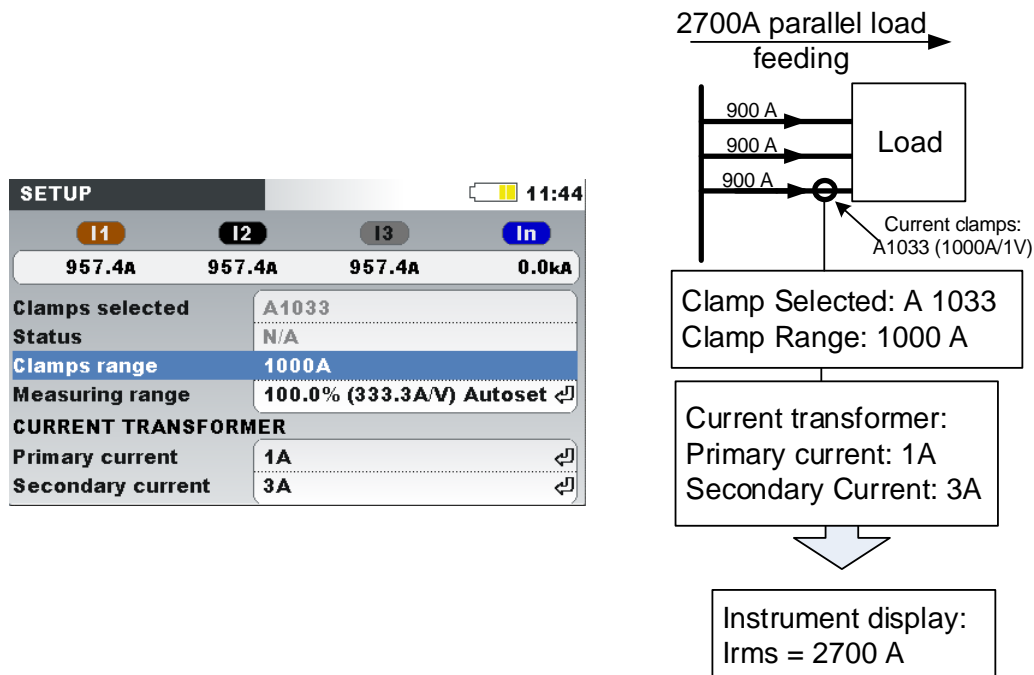

Figure 5.16: Parallel feeding of large load

Example: 2700 A current load is fed by 3 equal parallel cables. In order to measure current, we can embrace only one cable with clamps, and select: **Current transformer, Primary current: 1 A, Secondary current: 3A** in clamp menu. Instrument will assume that we measure only third part of current.

Note: During setup current range can be observed by “Measuring range: 100% (3000 A/V)” row.

5.2.3.3 Indirect current measurement

Indirect current measurement with primary current transducer is assumed if user selects 5 A current clamps: A 1588 or A 1037. Load current is in that case measured **indirectly** through additional primary current transformer.

In **example** below we have 100 A of primary current flowing through primary transformer with ratio 600 A : 5 A. Settings are shown in following figure.

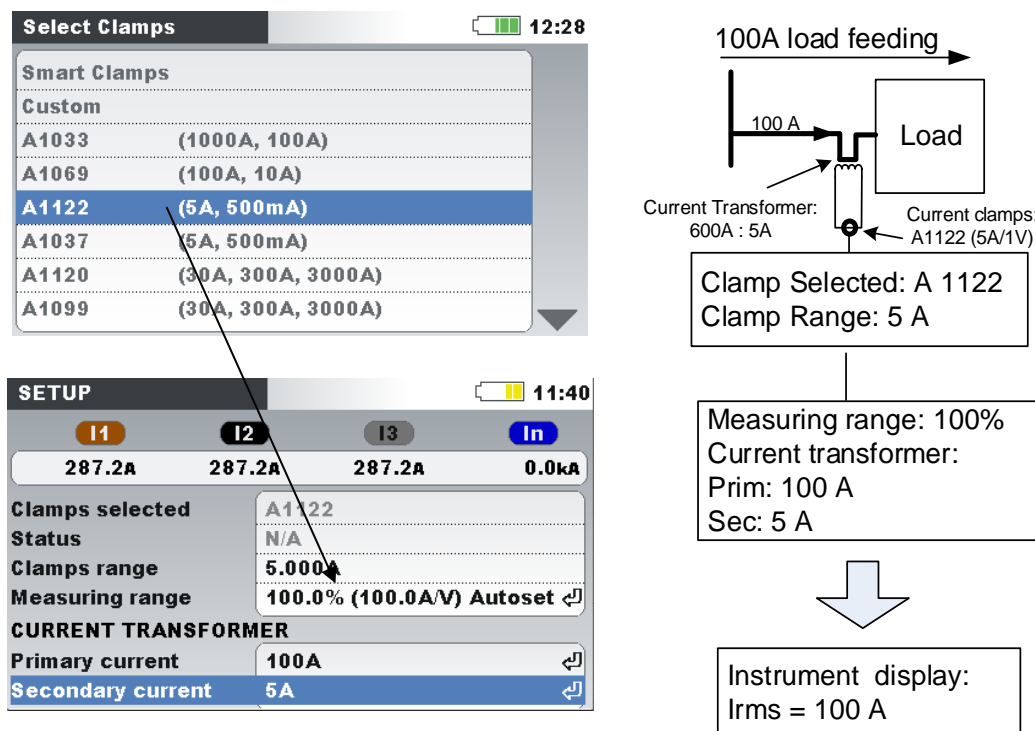

Figure 5.17: Current clamps selection for indirect current measurement

5.2.3.4 Over-dimensioned current transformer

Installed current transformers on the field are usually over-dimensioned for “possibility to add new loads in future”. In that case current in primary transformer can be less than 10% of rated transformer current. For such cases it is recommended to select 10% current range as shown on figure below.

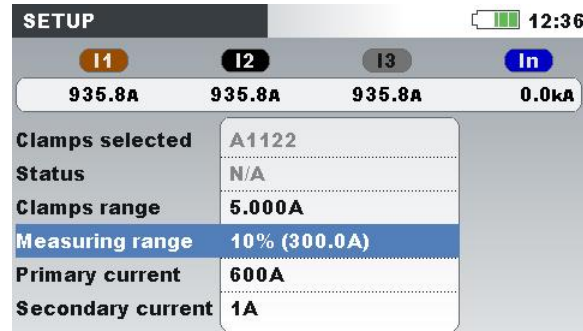

Figure 5.18: Selecting 10% of current clamps range

Note that if we want to perform direct current measure with 5 A clamps, primary transformer ratio should be set to 5 A: 5 A.

⚠ WARNINGS!

- The secondary winding of a current transformer must not be open when it is on a live circuit.
- An open secondary circuit can result in dangerously high voltage across the terminals.

5.2.3.5 Automatic current clamps recognition

Metrel developed Smart current clamps product family in order to simplify current clamps selection and settings. Smart clamps are multi-range switchless current clamps automatically recognized by instrument. In order to activate smart clamp recognition, the following procedure should be followed for the first time:

1. Turn on the instrument
2. Connect clamps (for example A 1227) to Energy Master XA/Energy Master
3. Enter: Measurement Setup → Connection setup → Phase/Neutral Curr. Clamps menu
4. Select: Smart clamps
5. Clamps type will be automatically recognized by the instrument.
6. User should then select clamp range and confirm settings.

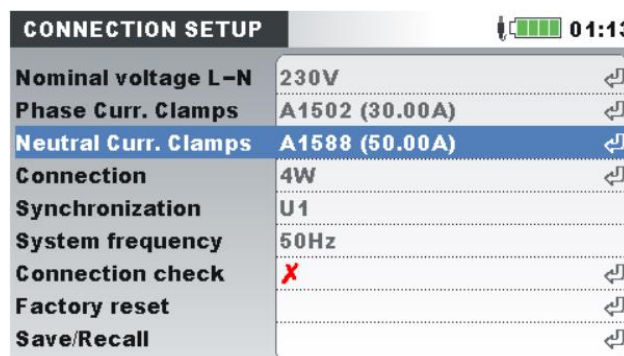

Figure 5.19: Automatically recognised clamps setup

Instrument will remember clamps setting for the next time. Therefore, user only need to:

1. Plug clamps to the instrument current input terminals
2. Turn on the instrument

Instrument will recognize clamps automatically and set ranges as was settled on measurement before. If clamps were disconnected following pop up will appear on the screen (See Figure below). Use cursor keys to select Smart clamp current range.

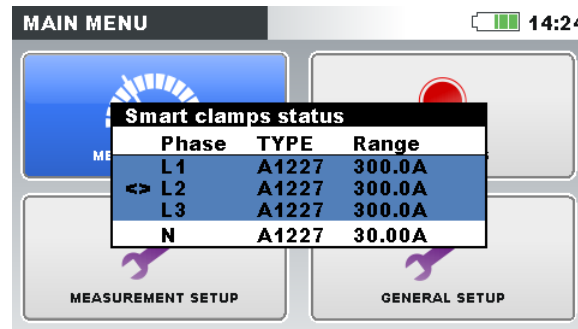

Figure 5.20: Automatically recognised clamps status

Table 5.1: Keys in Smart clamps pop up window

	Changes Clamps current range.
	Selects Phase or Neutral current clamps.
	Confirms selected range and returns to previous menu.

Clamps Status menu indicates that there is an inconsistency between current clamps defined in Clamps Setup menu and clamps present at the moment.

Note: Do not disconnect smart clamps during recording.

5.2.4 Connection check

Connection check menu in CONNECTION SETUP check if instrument measurement complies with instrument setup and connection.

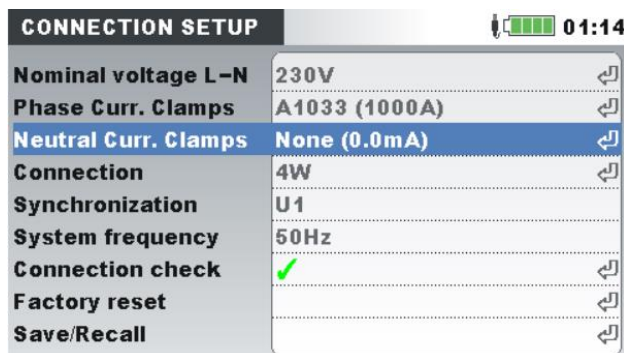

Connection check mark can be marked with OK (✓) or Fail (✗) sign and indicate overall connection status:











- Connection check is marked with green OK sign (✓) if instrument is connected properly and measured values comply with given measurement setup.
- Connection check is marked with yellow OK sign (✓), indicate that some measurement is not as expected. This does not mean that something is necessary wrong, but require user attention to double check connection and instrument settings.
- Fail sign (✗) indicate that that instrument is connected incorrectly or measurement setup does not correspond with measured value. In this case it is necessary to readjust measurement settings, and check instrument connections.

By pressing ENTER key, detailed Connection check will be shown

Connection: Consumed 11:52				
	L1	L2	L3	N
U	✓ 230.1	✓ 229.9	✓ 230.3	v
I	✓ 100.5	✓ 100.6	✓ 100.6	1.861 A
P	22.35	22.35	22.38	kW
Phase	✓ -14.9	✓ -14.9	✓ -14.9	°
Useq	✓ 1 2 3		Ptot	67.08 kW
Iseq	✓ 1 2 3		f	✓ 49.996 Hz
CUR. DIR.		VIEW	AUTOSET I	LIMITS

Table 5.2: Connection check description and screen symbols

Measure ment	Status	Description	Action to resolve issue
U	✓	Measured voltage is within 90% ÷ 110% range. All voltage measurements (RMS, harmonics, voltage events) are valid.	
U	✗	Measured voltage is not within 90% ÷ 110% range of Nominal voltage. All voltage measurements (RMS, harmonics, voltage events) can be compromised.	Set correct Nominal voltage value and check voltage leads.
I	✓	Measured current is within 10% ÷ 110% of selected clamp measuring range. All current measurements (RMS, harmonics, voltage events) are valid.	
I	✓	Measured current is within 5% ÷ 10% of selected clamp measuring range.	If higher current is expected during recorder campaign, this warning can be ignored. Otherwise, it is recommended to decrease current range.

I		Measured current is less than 5% of clamp measuring range. Accuracy of current measurements (RMS, harmonics...) can be compromised.	Go to Current clamp settings and change Clamp Measuring Range or press AUTOSET I button and let instrument to choose optimal current range.
Phase		Phase angle between voltage and current is less than 90° . This indicate that measured current flow in the same direction as voltage. Power measurements are valid.	
Phase		Phase angle between voltage and current is more than 90° . This indicate that measured current has opposite flow than voltage. Power measurements are compromised.	Check clamp direction ( icon is present in status bar) and see if current channel corresponds to the voltage channel (if current I_1 is measured on voltage U_1)
Useq	 123	Voltage sequence is correct. Unbalance and power measurement are valid.	
Useq	 321	Voltage sequence is reverse. Unbalance and power measurement are compromised.	Switch voltage leads U_2 and U_3 in-between to obtain right sequence.
Useq	 -	Phase angle between voltages is not $120^{\circ} \pm 30^{\circ}$. Unbalance and power measurement are compromised.	Check voltage leads, and check if selected Connection correspond to the actual network.
Iseq	 123	Current sequence is correct, phase angle between currents is less than $120^{\circ} \pm 60^{\circ}$. Unbalance and power measurement are valid.	
Iseq	 123	Current sequence is correct, but phase angle between currents is more than $120^{\circ} \pm 60^{\circ}$.	This is valid situation if there are large inductive/capacitive load in the network. However, this can be also caused by improper instrument connection. Check clamp direction ( icon is present in status bar) and see if current channel corresponds to the voltage channel (if current I_1 is measured on voltage U_1).
Iseq	 321	Current sequence is reverse. Unbalance and power measurement are compromised.	Switch current clamps I_2 and I_3 in-between.

Iseq  Current phase angle between currents is not $120^{\circ} \pm 60^{\circ}$. Unbalance and power measurement are compromised. Check voltage leads, and check if selected Connection correspond to the actual network.

Table 5.3: Keys in Connection check screen

F1	CUR.DIR.	<p>Invert the current per phase in case of wrong current clamp installation</p>  <p>Example: Current direction in phase L1 is inverted by the Analyser firmware, so physical current clamp inversion is not needed.</p>
F2	VIEW	<p>Selects which measurement setup should be considered: Consumed or Generated.</p>
F3	AUTOSET I	<p>Autoset Clamp current range.</p>
F4	LIMITS	<p>Check limits for measured parameters:</p> 
ESC	<p>Returns to the "RECORDERS" submenu.</p>	

5.2.5 Temperature probe connection

Temperature measurement is performed using smart temperature probe¹ connected to the any current input channel. In order to activate temperature probe recognition, following procedure should be followed for the first time:

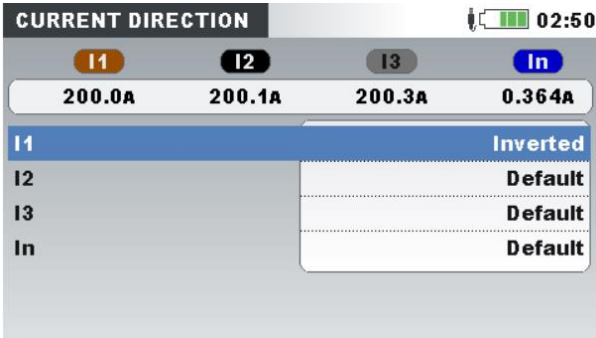
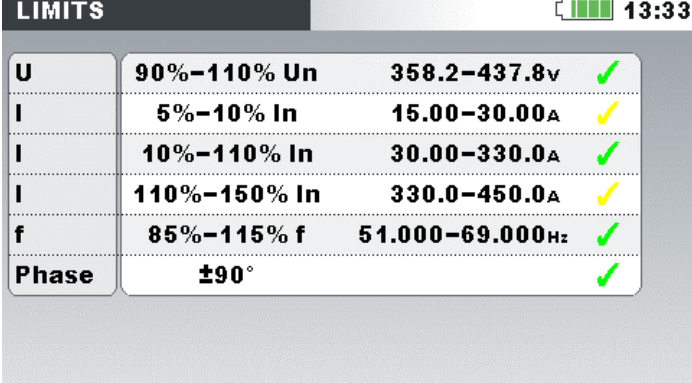
1. Turn on the instrument
2. Connect temperature probe to Power Master neutral current input terminal
3. Enter: Measurement setup → Connection setup → Phase/Neutral curr. clamps
4. Select: Smart clamps
5. Temperature probe should be now automatically recognized by the instrument

Instrument will remember settings for the next time. Therefore, user only needs to plug temperature probe to the instrument.

¹ Optional accessory

5.3 Instrument connection to powerView v3.0

Recorded data can be downloaded and observed by PowerView v3.0, accompanying software. Additionally, PowerView can be used for creating reports, real-time data monitoring and instrument configuration. Before use instrument should be connected to PC with USB cable. New, USB connection should be selected in PowerView → Tools → Options menu. Instrument should be then automatically recognised as “Measurement Instrument USB” device.

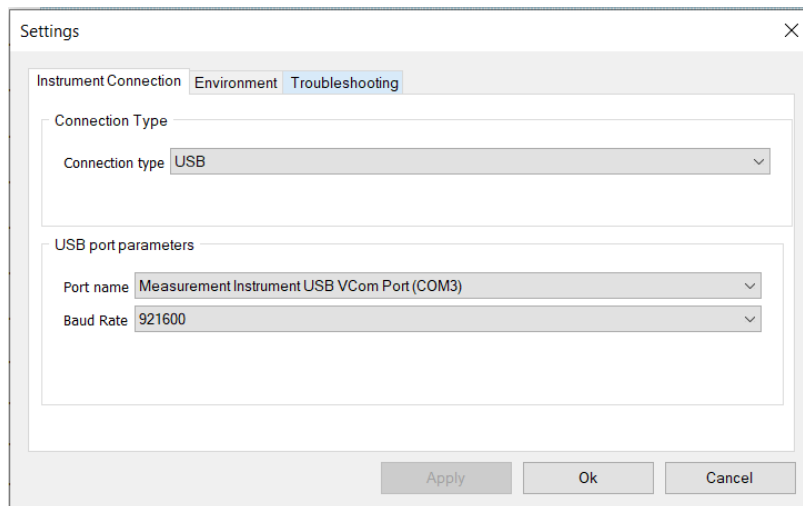
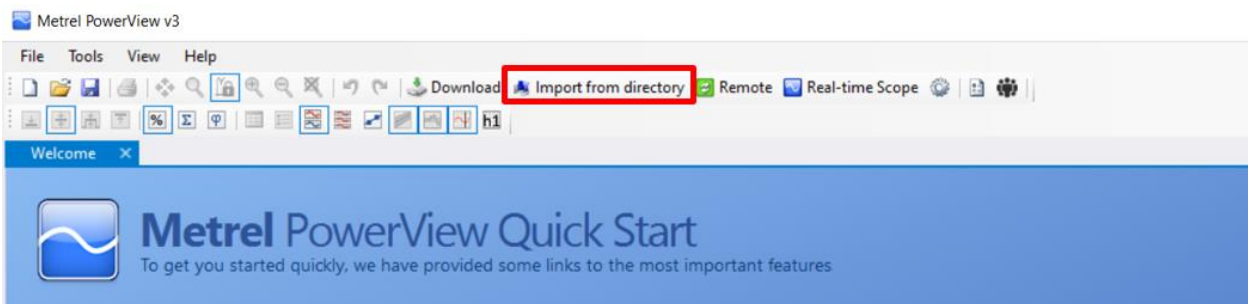

Figure 5.21: USB communication settings in PowerView

5.3.1.1 Downloading data with microSD card

The fastest option to import/download the data into the PC SW is to take the microSD card out of the instrument and insert it directly to computers card reader, in case there isn't one installed, use the one provided in standard set. Downloading of data via USB connection will take much longer and it is not recommended. To import the data from microSD card or from specific location on your HD, perform the following actions:

- Select: Tools / Import / From directory or click on icon “Import from directory”



Alternatively, user can Import data directly from instrument and use USB connection

Note: before downloading the data, setup the communication parameters → Tools / Options or click on the icon

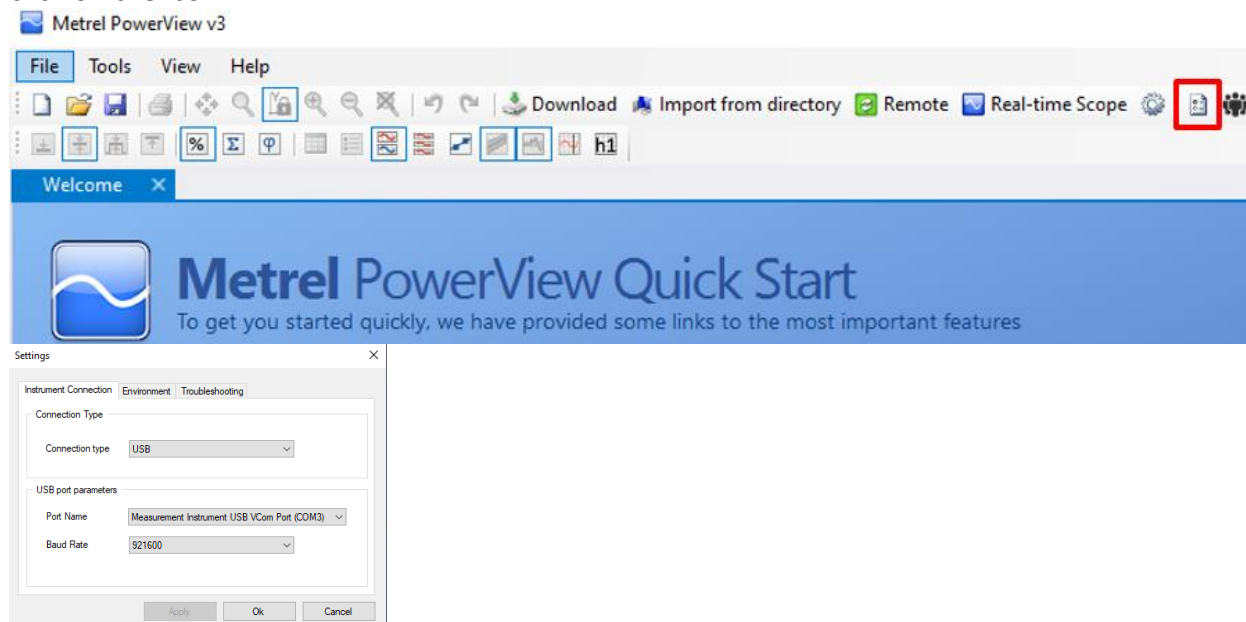

- Select: Tools / Import / From instrument or click on icon “Download”

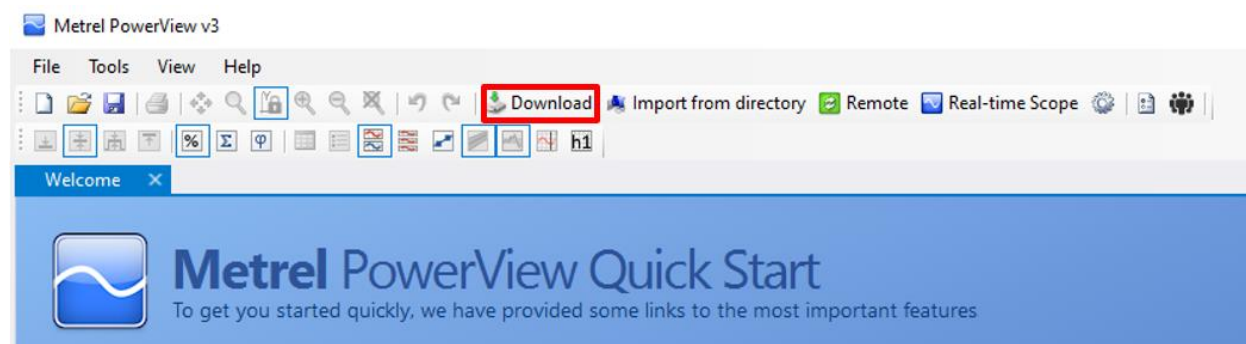

Download window will be displayed, and PowerView v3.0 will immediately try to connect to the instrument and detect the instrument model and firmware version.

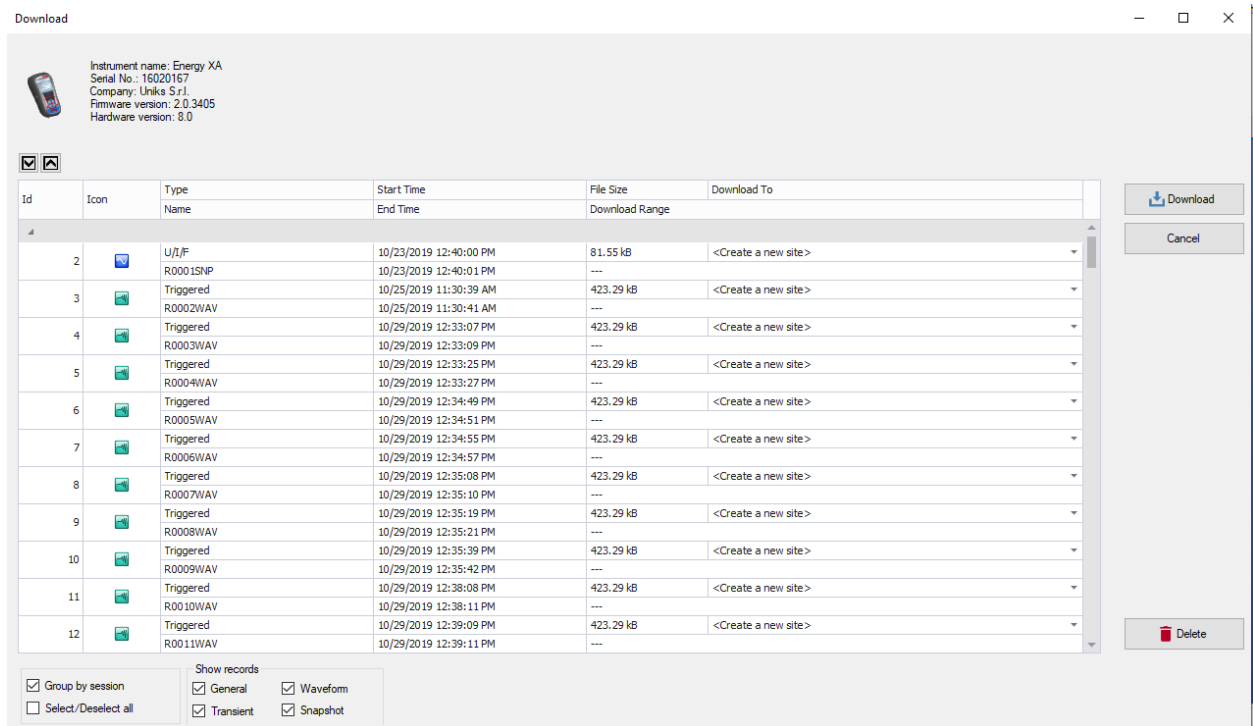

Figure 5.22: Detection of the instrument type

After a moment, instrument type should be detected, or an error message will be received, with the appropriate explanation. If connection can't be established, please check your connection settings.

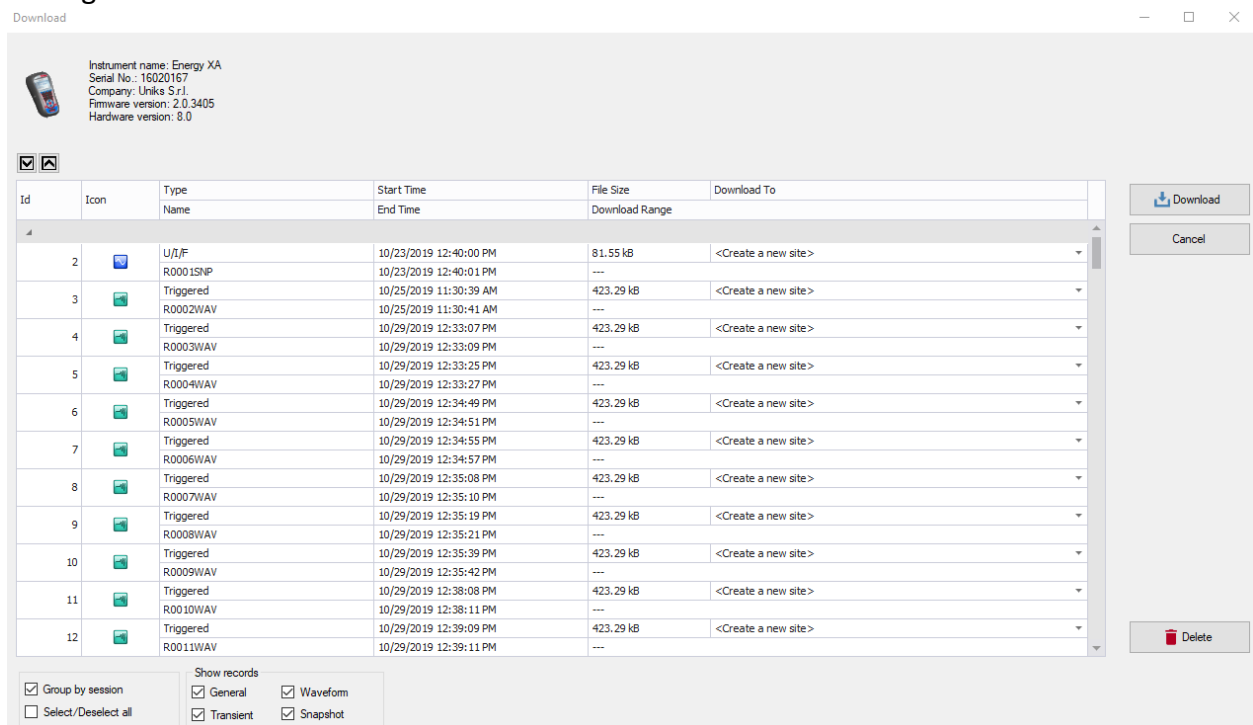

Figure 5.23: Downloading a list of records

When the instrument model is detected, PowerView v3.0 will download a list of records from the instrument. Any of the records from the list can be selected by simply clicking on them. Additional, “Select/Deselect all” tick box is available to select or deselect all records on displayed page. Selected records entries will have a green background.

Before downloading, a destination site node for each record can be defined. Each entry in a list contains a drop-down list of sites in all currently open documents in PowerView v3.0. If no document is opened, all records will be downloaded to a new site and saved into a new file.

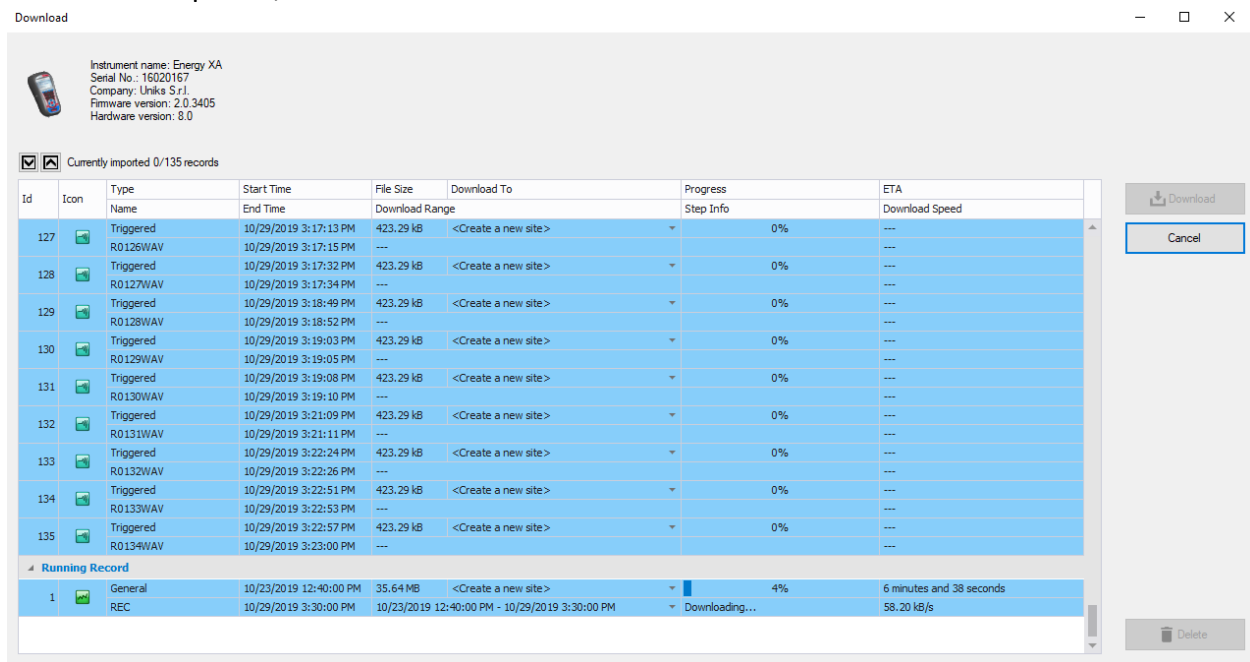

Figure 5.24: Selecting records from a list for download

Figure above show example were first two records are select. To start download, click on the “Start importing” button.

5.3.1.2 Real time scope

Click the button to open the Real time scope window. A new document window will be opened, as shown on the picture below.

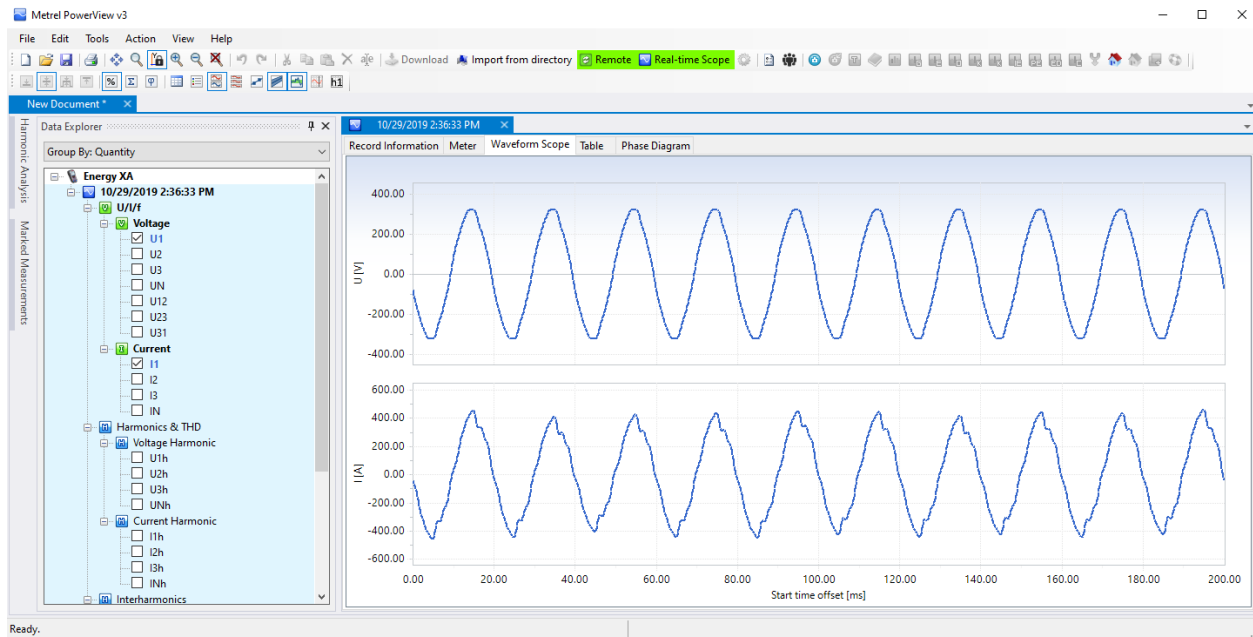

Figure 5.25: Real time scope window in remote connection, with several channels selected

The figure above shows an online window, with several channels selected. While online view is active, data are automatically updated. Updating speed will depend on your connection speed, and each new update is initiated as soon as the previous one has been downloaded, to ensure fastest possible refresh rate. While Real time scope is active, **Real-Time Scope** button is displayed in green, to indicate that the connection is active.

To close the online view, click the **Real-Time Scope** button again, or close the online window.

5.3.1.3 Instrument configuration

Instrument configuration tool helps you to change instrument settings, manage recording settings, start or stop recordings and manage instrument memory remotely. In order to begin, select “Configure instrument” in PowerView v3.0 “Tools” menu. A form shown on figure below should pop up on the screen.

Note: Remote connection procedure described in 5.3 should be performed successfully before starting remote instrument configuration.

Note: MI 2884XA could not be connected remotely, but instrument could be managed via USB port.

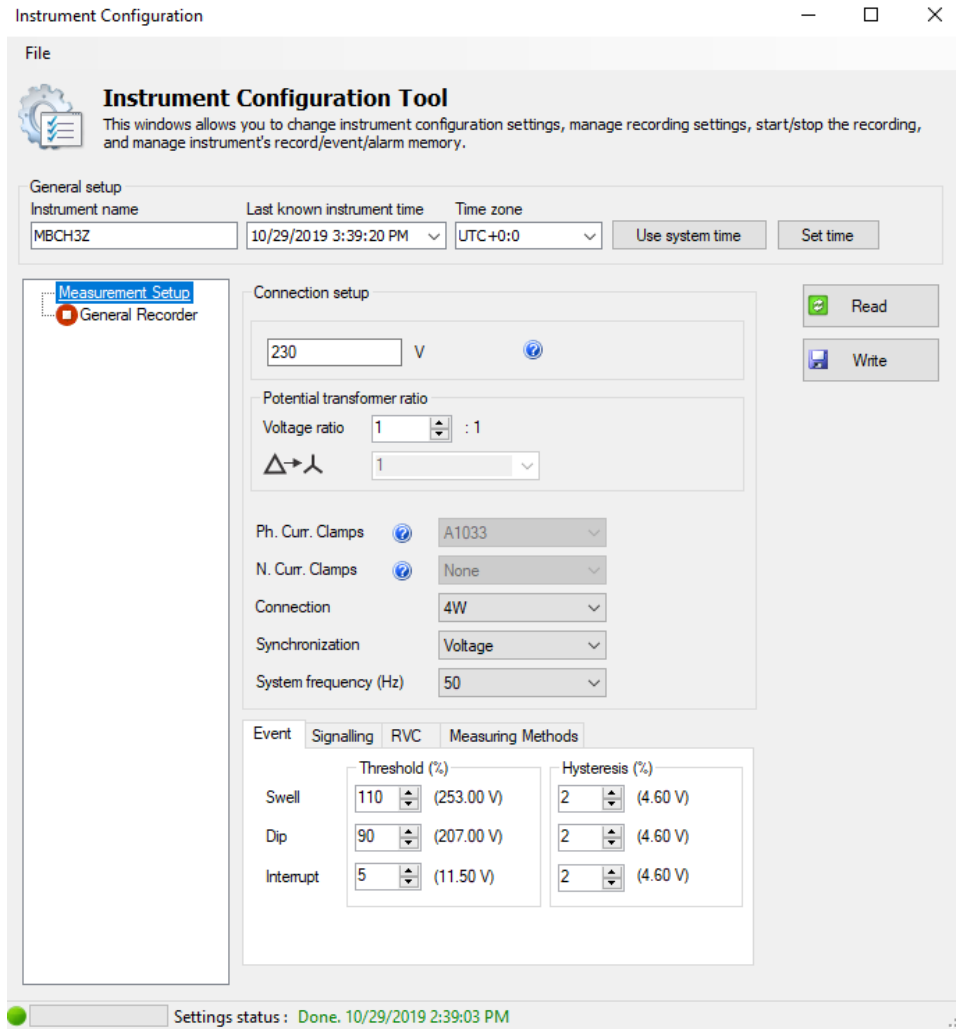

Figure 5.26: Remote Instrument Configuration form

Please click on the “Read” button in order to receive current instrument settings. After retrieving data from the remote instrument, form should be filled with data, as shown on figure below. Changed parameters, will be sent back to the instrument by clicking on the “Write” button. In order to remotely control instrument recorders, please click on the “Recorder” node as shown on figure below. User can select any of the instrument recorders and configure accompanying parameters. For description of particular recorder settings, see appropriate section in this manual. Changed parameters, will be sent back to the instrument by clicking on the “Write” button.

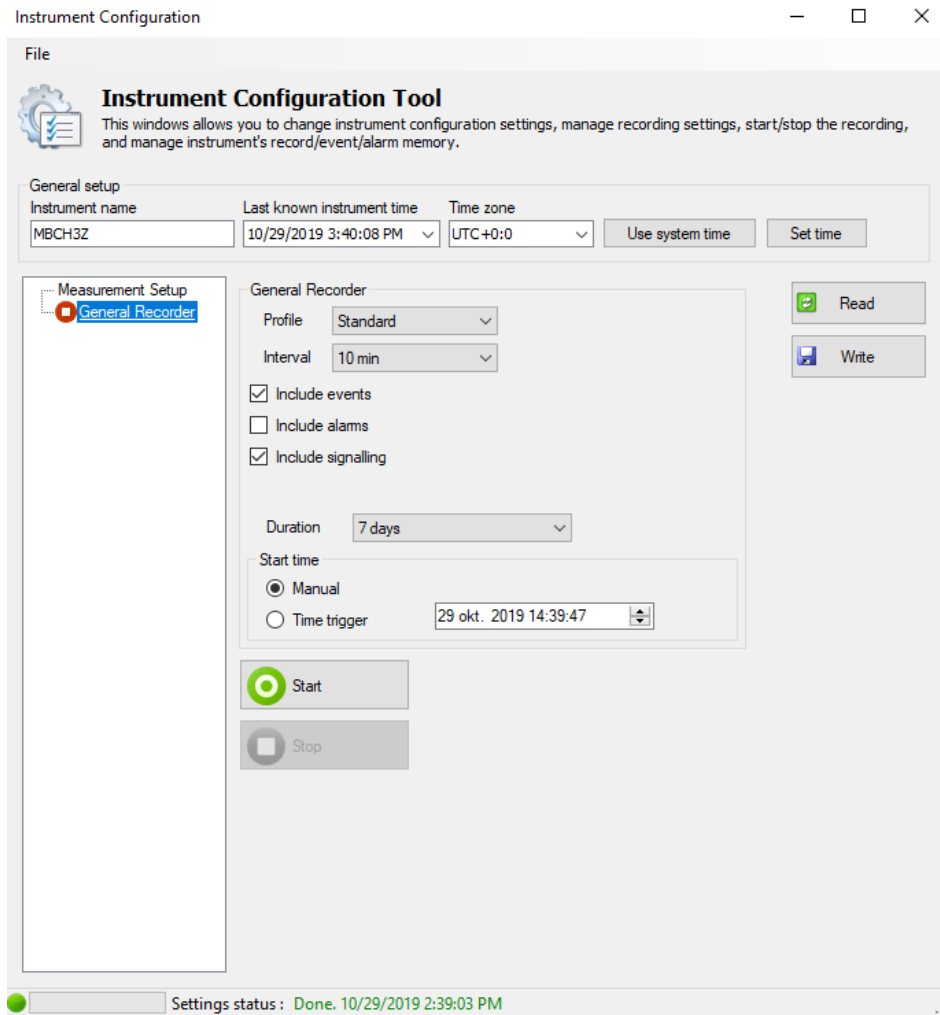

Figure 5.27: Remote Recorder configuration

By clicking on “Start” button, instrument will start selected recorder in the same manner as would user start recorder directly on instrument. Green icon indicates that Recorder is active, while red icon indicates that recorder is stopped.

Additionally, PowerView v3.0 will disable changing parameters during recording. Recording can be terminated by pressing on “Stop” button, or will automatically finish, after conditions are met, for example after given period of time or after event capturing. By pressing on “Read” button, user can receive instrument status in any moment.

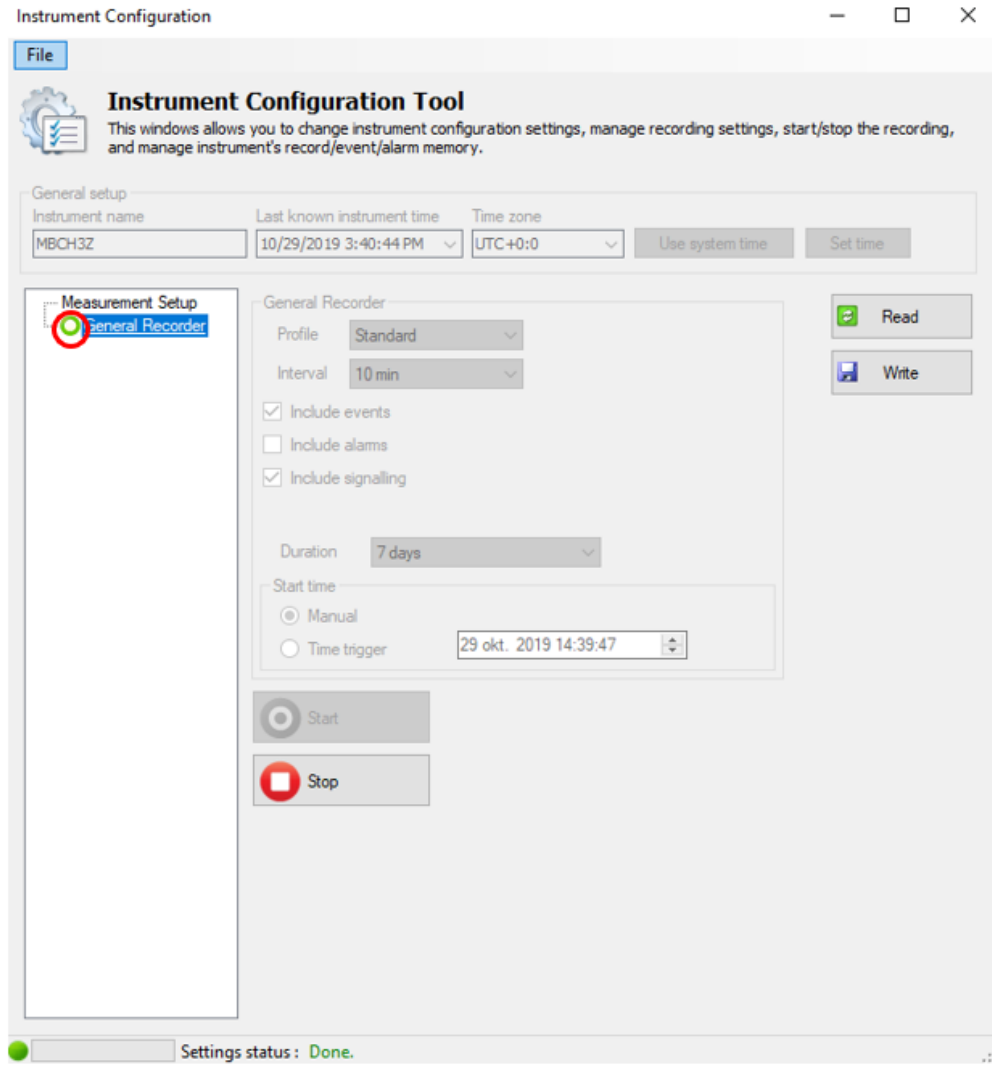

Figure 5.28: Recording in progress

5.4 Number of measured parameters and connection type relationship

Parameters which Energy Master XA/Energy Master displays and measures, mainly depends on network type, defined in CONNECTION SETUP menu – Connection type. In example if user choose single phase connection system, only measurements relate to single phase system will be present. Table below shows dependencies between measurement parameters and type of network.

Table 5.4: Quantities measured by instrument

Menu		Connection type																							
		1W		2W				3W				OpenD				4W									
		L1	N	L1	L2	N	L12	Tot	L12	L23	L31	Tot	L12	L23	L31	Tot	L1	L2	L3	N	L12	L23	L31	Tot	
Voltage	RMS	•		•	•		•		•	•	•		•	•	•		•	•	•		•	•	•		
	THD	•		•	•				•	•	•		•	•	•		•	•	•						
	Crest Factor	•		•	•		•		•	•	•		•	•	•		•	•	•		•	•	•		
	Frequency	•		•					•				•				•								
	Harmonics (0:50)	•		•	•				•	•	•		•	•	•		•	•	•						
	Interharm. (0:50)	•		•	•				•	•	•		•	•	•		•	•	•						
	Unbalance							•				•				•								•	
	Flicker	•		•	•				•	•	•		•	•	•		•	•	•						
	Signalling	•		•	•				•	•	•		•	•	•		•	•	•						
	Events	•		•	•				•	•	•		•	•	•		•	•	•						
		L1	N	L1	L2	N	L12	Tot	L1	L2	L3	Tot	L12	L23	L31	Tot	L1	L2	L3	N	L12	L23	L31	Tot	
Current	RMS	•	•	•	•				•	•	•		•	•	•		•	•	•						
	THD	•	•	•	•				•	•	•		•	•	•		•	•	•						
	Harmonics (0:50)	•	•	•	•				•	•	•		•	•	•		•	•	•						
	Interharm. (0:50)	•	•	•	•				•	•	•		•	•	•		•	•	•						
	Unbalance							•				•				•								•	
Consumed Pwr.	Combined	•		•	•			•				•				•	•	•	•	•				•	
	Fundamental	•		•	•			•				•				•	•	•	•	•				•	
	Nonfundament.	•		•	•			•				•				•	•	•	•	•				•	
	Energy	•		•	•			•				•				•	•	•	•	•				•	
	Power factors	•		•	•			•				•				•	•	•	•	•				•	
Generated Pwr.	Combined	•		•	•			•				•				•	•	•	•	•				•	
	Fundamental	•		•	•			•				•				•	•	•	•	•				•	
	Nonfundament.	•		•	•			•				•				•	•	•	•	•				•	
	Energy	•		•	•			•				•				•	•	•	•	•				•	
	Power Factors	•		•	•			•				•				•	•	•	•	•				•	

Note: Frequency measurement depends on synchronization (reference) channel, which can be voltage or current.

In the same manner recording quantities are related to connection type too. Signals in GENERAL RECORDER menu, channels selected for recording are chosen according to the **Connection** type, according to the next table.

Table 5.5: Quantities recorded by instrument (Standard profile)

		Connection type																							
Menu		1W		2W				3W				OpenD				4W									
		L1	N	L1	L2	N	L12	Tot	L12	L23	L31	Tot	L12	L23	L31	Tot	L1	L2	L3	N	L12	L23	L31	Tot	
Voltage	RMS																								
	THD																								
	Crest Factor																								
	Frequency																								
	Harmonics (0/50)																								
	Interharm. (0/50)																								
	Unbalance																								
	Flicker																								
	Signalling																								
	Events	•		•	•				•	•	•		•	•	•		•	•	•						
		L1	N	L1	L2	N	L12	Tot	L12	L1	L2	L3	Tot	L2	L3	Tot	L1	L2	L3	N	L12	L23	L31	Tot	
Current	RMS																								
	THD																								
	Harmonics (0/50)																								
	Interharm. (0/50)																								
	Unbalance																								
		L1	N	L1	L2	N	L12	Tot	L12	L1	L2	L3	Tot	L2	L3	Tot	L1	L2	L3	N	L12	L23	L31	Tot	
Power	Combined																								
	Fundamental																								

Nonfundament.																								

Table 5.5: Quantities recorded by instrument (Limited profile)

		Connection type																										
Menu		1W		2W				3W				OpenD				4W												
		L1	N	L1	L2	N	L12	Tot	L12	L23	L31	Tot	L12	L23	L31	Tot	L1	L2	L3	N	L12	L23	L31	Tot				
Voltage	RMS																											
	THD																											
	Crest Factor																											
	Frequency																											
	Harmonics (0/50)																											
	Interharm. (0/50)																											
	Unbalance																											
	Flicker																											
	Signalling																											
	Events	•		•	•				•	•	•		•	•	•		•	•	•									
		L1	N	L1	L2	N	L12	Tot	L12	L1	L2	L3	Tot	L2	L3	Tot	L1	L2	L3	N	L12	L23	L31	Tot				
Current	RMS																											
	THD																											
	Harmonics (0/50)																											
	Interharm. (0/50)																											
	Unbalance																											
		L1	N	L1	L2	N	L12	Tot	L12	L1	L2	L3	Tot	L2	L3	Tot	L1	L2	L3	N	L12	L23	L31	Tot				
Power	Combined																											
	Fundamental																											

Nonfundament.																			
Active Energy																			
Reactive Ener.																			
Power factors	 					 			 			 	 	 				 	

Legend:

- - Quantity included.
- Maximal value for each interval is recorded.
- RMS or arithmetic average for each interval is recorded (see 6.1.15 for details).
- Minimal value for each interval is recorded.
- Active RMS or arithmetic average (AvgON) for each interval is recorded (see 6.1.15 for details).

6 Theory and internal operation

This section contains basic theory of measuring functions and technical information of the internal operation of the Energy Master XA/Energy Master instrument, including descriptions of measuring methods and logging principles.

6.1 Measurement methods

6.1.1 Measurement aggregation over time intervals

Standard compliance: IEC 61000-4-30 Class A (Section 4.4)

The basic measurement time interval for:

- Voltage
- Current
- Power
- Harmonics
- Interharmonics
- Signalling
- Unbalance

is a 10/12-cycle time interval. The 10/12-cycle measurement is resynchronized on each Interval tick according to the IEC 61000-4-30 Class A. Measurement methods are based on the digital sampling of the input signals, synchronised to the fundamental frequency. Each input (3 voltages and 4 currents) is simultaneously sampled.

6.1.2 Voltage measurement (magnitude of supply voltage)

Standard compliance: IEC 61000-4-30 Class S (Section 5.2)

All voltage measurements represent RMS values of the voltage magnitude over a 10/12-cycle time interval. Every interval is contiguous, and not overlapping with adjacent intervals.

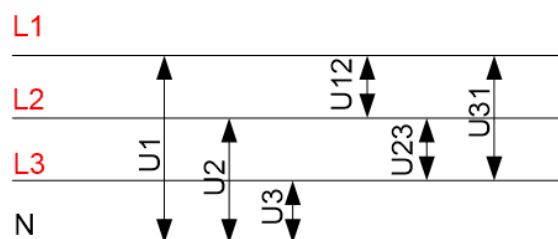

Figure 6.1: Phase and Phase-to-phase (line) voltage

Voltage values are measured according to the following equation:

$$\text{Phase voltage: } U_p = \sqrt{\frac{1}{M} \sum_{j=1}^M u_{pj}^2} \quad [V], p: 1,2,3,N \quad (1)$$

$$\text{Line voltage: } U_{pg} = \sqrt{\frac{1}{M} \sum_{j=1}^M (u_{pj} - u_{gj})^2} \text{ [V], pg.: 12,23,31} \quad (2)$$

$$\text{Phase voltage crest factor: } CF_{U_p} = \frac{U_{pPk}}{U_p}, p: 1,2,3,N \quad (3)$$

$$\text{Line voltage crest factor: } CF_{U_{pg}} = \frac{U_{pgPk}}{U_{pg}}, pg: 12, 23, 31 \quad (4)$$

The instrument has internally 4 voltage measurement ranges, which are automatically selected regarding to the nominal voltage.

6.1.3 Current measurement (magnitude of supply current)

Standard compliance: Class S (Section 5.13)

All current measurements represent RMS values of the samples of current magnitude over a 10/12-cycle time interval. Each 10/12-cycle interval is contiguous and non-overlapping. Current values are measured according to the following equation:

$$\text{Phase current: } I_p = \sqrt{\frac{1}{M} \sum_{j=1}^M I_{pj}^2} \text{ [A], } p: 1,2,3,N \quad (5)$$

$$\text{Phase current crest factor: } I_{p_{cr}} = \frac{I_{p_{\max}}}{I_p}, p: 1,2,3,N \quad (6)$$

The instrument has internally two current ranges: 10% and 100% range of nominal transducer current. Additionally, Smart current clamps models offer few measuring ranges and automatic detection.

6.1.4 Frequency measurement

Standard compliance: IEC 61000-4-30 Class A (Section 5.1)

During RECORDING with aggregation time Interval: ≥ 10 sec frequency reading is obtained every 10 s. The fundamental frequency output is the ratio of the number of integral cycles counted during the 10 s time clock interval, divided by the cumulative duration of the integer cycles. Harmonics and interharmonics are attenuated with digital filter in order to minimize the effects of multiple zero crossings.

The measurement time intervals are non-overlapping. Individual cycles that overlap the 10 s time clock are discarded. Each 10 s interval begin on an absolute 10 s time clock, with uncertainty as specified in section 7.2.19.

For RECORDING with aggregation time Interval: < 10 sec and on-line measurements, frequency reading is obtained from 10/12 cycles frequency. The frequency is ratio of 10/12 cycles, divided by the duration of the integer cycles.

Frequency measurement is *performed* on chosen Synchronization channel, in CONNECTION SETUP menu.

6.1.5 Modern Power measurement

Standard compliance: IEEE 1459-2010

See section 4.21.6 how to select Modern Power measurement method. Please note that instrument record all measurement (Classic and Modern), regardless of selected method.

Instrument fully complies with power measurement defined in the latest IEEE 1459 standard. The old definitions for active, reactive, and apparent powers are valid as long as the current and voltage waveforms remained nearly sinusoidal. This is not the case today, where we have various power electronics equipment, such as Adjustable Speed Drives, Controlled Rectifiers, Cyclo-converters, Electronically Ballasted Lamps. Those represent major nonlinear and parametric loads proliferating among industrial and commercial customers. New Power theory splits power to fundamental and nonfundamental components, as shown on figure below.

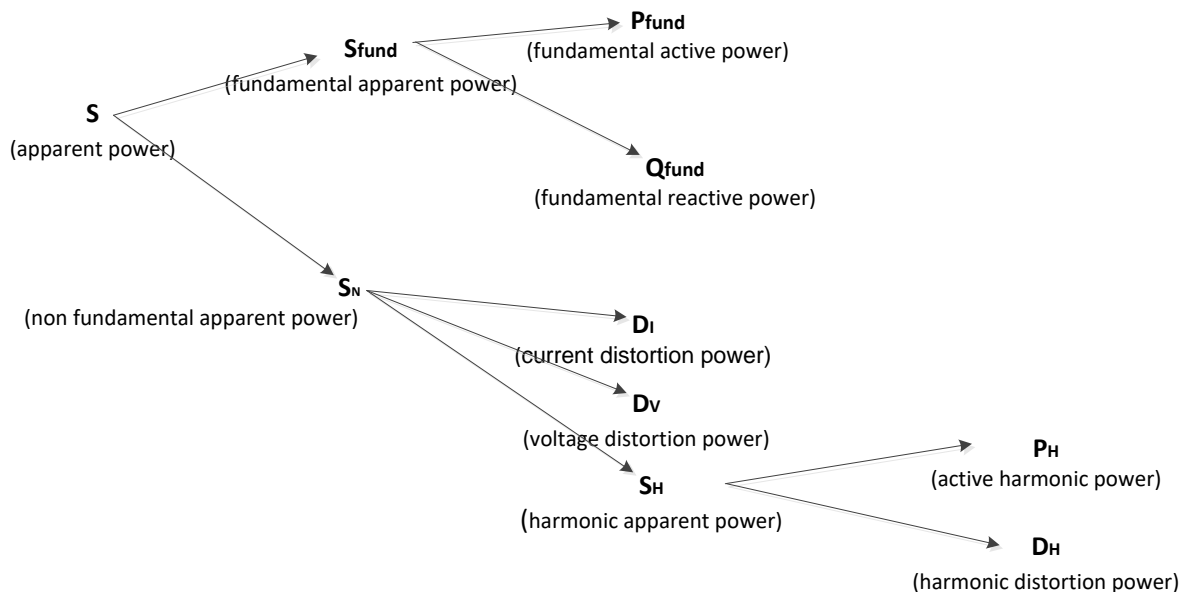

Figure 6.2: IEEE 1459 phase power measurement organisation (phase)

In table below summary of all power measurement is shown.

Table 6.1: Summary and grouping of the phase power quantities

Quantity	Combined powers	Fundamental powers	Nonfundamental Powers
Apparent (VA)	S	Sfund	SN, SH
Active (W)	P	Pfund	PH
Nonactive/reactive (var)	N	Qfund	DI, DV, DH
Line utilization	PF _{ind/cap}	DPF _{ind/cap}	-

Harmonic pollution (%) - - S_N/S_{fund}

Power measurement for three phase systems are slightly different as shown on figure below.

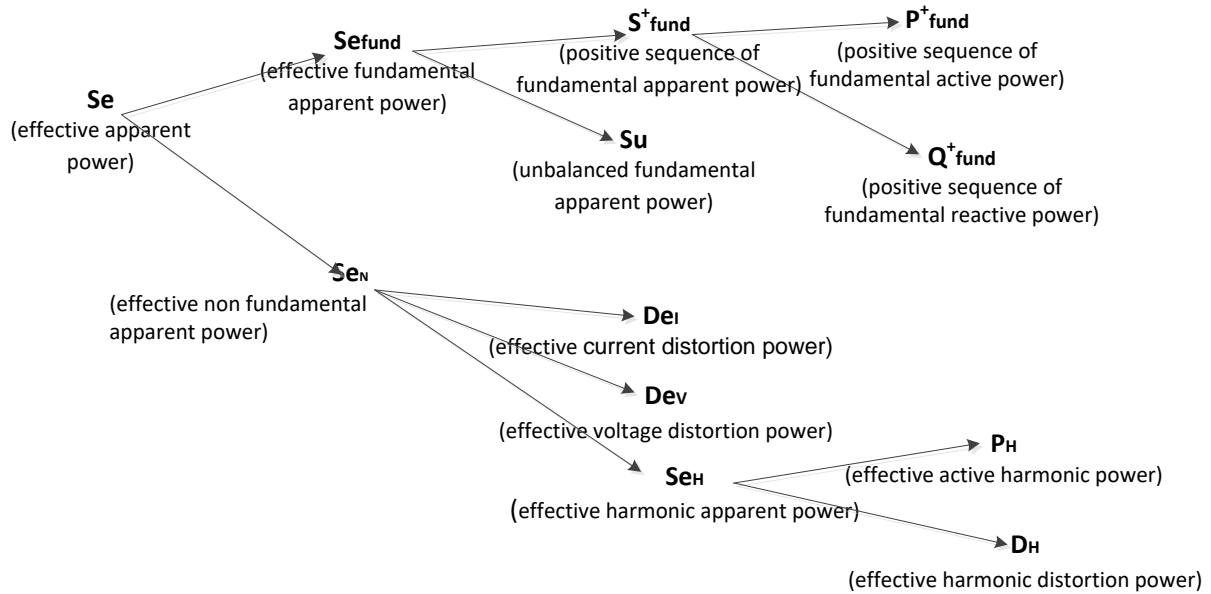

Figure 6.3: IEEE 1459 phase power measurement organisation (totals)

Table 6.2: Power summary and grouping of the total power quantities

Quantity	Combined powers	Fundamental powers	Nonfundamental Powers
Apparent (VA)	Se	Se _{fund} , S ⁺ , Su	Se _N , Se _H
Active (W)	P	P ⁺ _{tot}	P _H
Nonactive/reactive (var)	N	Q ⁺ _{tot}	De _I , De _V , De _H
Line utilization	PF _{ind/cap}	DPF ⁺ _{tot ind/cap}	-
Harmonic pollution (%)	-	-	Se _N /S _{fund}

6.1.5.1 Combined phase power measurements

Standard compliance: IEEE STD 1459-2010

All combined (fundamental + nonfundamental) active power measurements represent RMS values of the samples of instantaneous power over a 10/12-cycle time interval. Each 10/12-cycle interval is contiguous and non-overlapping.

Combined phase active power:

$$P_p = \frac{1}{N} \sum_{j=1}^N P_{p_j} = \frac{1}{N} \sum_{j=1}^N U_{p_j} * I_{p_j} \quad [W], p: 1,2,3 \quad (7)$$

Combined apparent and nonactive power, and power factor are calculated according to the following equations:

Combined phase apparent power:

$$S_p = U_p * I_p \quad [VA], p: 1,2,3 \quad (8)$$

Combined phase nonactive power:

$$N_p = \text{Sign}(Q_p) \cdot \sqrt{S_p^2 - P_p^2} \quad [\text{var}], p: 1,2,3 \quad (9)$$

Phase power factor: $PF_p = \frac{P_p}{S_p}, p: 1,2,3 \quad (10)$

6.1.5.2 Total combined power measurements

Standard compliance: IEEE STD 1459-2010

Total combined (fundamental + nonfundamental) active, nonactive and apparent power and total power factor are calculated according to the following equation:

Total active power: $P_{tot} = P1 + P2 + P3 \quad [\text{W}], \quad (11)$

Total nonactive power: $N_{tot} = N1 + N2 + N3 \quad [\text{var}], \quad (12)$

Total apparent power (effective): $Se_{tot} = 3 \cdot U_e \cdot I_e \quad [\text{VA}], \quad (13)$

Total power factor (effective): $PF_{e_{tot}} = \frac{P_{tot}}{Se_{tot}}. \quad (14)$

In this formula U_e and I_e are calculated differently for three phase four wire (4W) and three phase three wire (3W) systems.

Effective voltage U_e and current I_e in 4W systems:

$$I_e = \sqrt{\frac{I_1^2 + I_2^2 + I_3^2 + I_N^2}{3}} \quad U_e = \sqrt{\frac{3 \cdot (U_1^2 + U_2^2 + U_3^2) + U_{12}^2 + U_{23}^2 + U_{31}^2}{18}} \quad (15)$$

Effective voltage U_e and current I_e in 3W systems:

$$I_e = \sqrt{\frac{I_1^2 + I_2^2 + I_3^2}{3}} \quad U_e = \sqrt{\frac{U_{12}^2 + U_{23}^2 + U_{31}^2}{9}} \quad (16)$$

6.1.5.3 Fundamental phase power measurements

Standard compliance: IEEE STD 1459-2010

All fundamental power measurements are calculated from fundamental voltages and currents obtained from harmonic analysis (see section 6.1.8 for details).

Fundamental phase active power:

$$P_{fundP} = U_{fundP} \cdot I_{fundP} \cdot \cos \varphi_{U_p - I_p} \quad [\text{W}], p: 1,2,3 \quad (17)$$

Fundamental apparent and reactive power and power factor are calculated according to the following equations:

Fundamental phase apparent power:

$$S_{fundP} = U_{fundP} \cdot I_{fundP} \quad [\text{VA}], p: 1,2,3 \quad (18)$$

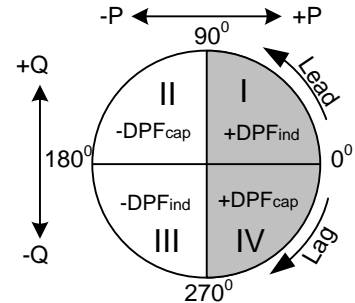

Fundamental phase reactive power:

$$Q_{fundP} = U_{fundP} \cdot I_{fundP} \cdot \sin \varphi_{U_p-I_p} \quad [\text{var}], p: 1,2,3 \quad (19)$$

Phase displacement power factor:

$$DPF_p = \cos \varphi_p = \frac{P_p}{S_p}, p: 1,2,3 \quad (20)$$

6.1.5.4 Positive sequence (total) fundamental power measurements

Standard compliance: IEEE STD 1459-2010

According to the IEEE STD 1459, positive sequence power (P^+ , Q^+ , S^+) are recognised as very important intrinsic power measurements. They are calculated according to the following equation:

Positive sequence active power:

$$P_{tot}^+ = 3 \cdot U^+ \cdot I^+ \cos \varphi^+ \quad [\text{W}], \quad (21)$$

Positive sequence reactive power:

$$Q_{tot}^+ = 3 \cdot U^+ \cdot I^+ \sin \varphi^+ \quad [\text{var}], \quad (22)$$

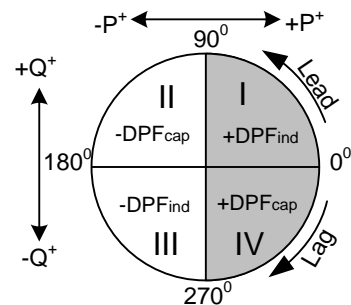

Positive sequence apparent power:

$$S_{tot}^+ = 3 \cdot U^+ \cdot I^+ \quad [\text{VA}], \quad (23)$$

Positive sequence power factor:

$$DPF_{tot}^+ = \frac{P_{tot}^+}{S_{tot}^+}. \quad (24)$$

U^+ , U^- , U^0 and φ^+ are obtained from unbalance calculus. See section 6.1.11 for details.

6.1.5.5 Nonfundamental phase power measurements

Standard compliance: IEEE STD 1459-2010

Nonfundamental power measurements are measured according to following equations:

Phase nonfundamental apparent power:

$$S_{Np} = \sqrt{D_{Ip}^2 + D_{Vp}^2 + S_{Hp}^2} \quad [\text{VA}], p: 1,2,3 \quad (25)$$

Phase current distortion power

$$D_{Ip} = S_{fundP} \cdot THD_{Ip} \quad [\text{VA}], p: 1,2,3 \quad (26)$$

Phase voltage distortion power:

$$D_{Vp} = S_{fundP} \cdot THD_{Up} \quad [\text{var}], p: 1,2,3 \quad (27)$$

Phase harmonic apparent power

$$S_{Hp} = S_{fundP} \cdot THD_{Up} \cdot THD_{Ip} \quad [\text{var}], p: 1,2,3 \quad (28)$$

Phase active harmonic power:

$$P_{Hp} = P_p - P_{fundP} \quad [\text{W}], p: 1,2,3 \quad (29)$$

Phase harmonic distortion power

$$D_{Hp} = \sqrt{S_{Hp}^2 - P_{Hp}^2} \quad [\text{var}], p: 1,2,3 \quad (30)$$

6.1.5.6 Total nonfundamental power measurements

Standard compliance: IEEE STD 1459-2010

Total nonfundamental power quantities are calculated according to the following equations:

Total nonfundamental effective apparent power:

$$SeN_{tot} = \sqrt{DeI_{tot}^2 + DeV_{tot}^2 + SeH_{tot}^2} \quad [\text{VA}] \quad (31)$$

Total effective current distortion power:

$$DeI_{tot} = 3 \cdot Ue_{fund} \cdot IeH \quad [\text{var}] \quad (32)$$

where:

$$IeH = \sqrt{Ie^2 - Ie_{fund}^2}$$

Total effective voltage distortion power:

$$DeV_{tot} = 3 \cdot Ue_H \cdot Ie_{fund} \quad [\text{var}] \quad (33)$$

where:

$$Ue_H = \sqrt{Ue^2 - Ue_{fund}^2}$$

Total effective apparent power:

$$SeH_{tot} = Ue_H \cdot Ie_H \quad [\text{VA}] \quad (34)$$

Total effective harmonic power:

$$PH_{tot} = PH_1 + PH_2 + PH_3 \quad [\text{W}] \quad (35)$$

where:

$$PH_1 = P_1 - P_{fund1}, \quad PH_2 = P_2 - P_{fund2}, \quad PH_3 = P_3 - P_{fund3}$$

Total effective distortion power

$$DeH = \sqrt{SeH^2 - PH^2} \quad [\text{var}] \quad (36)$$

Harmonic pollution

$$HP = \frac{SeN_{tot}}{Se_{fundtot}} \cdot 100 [\%] \quad (37)$$

where:

$$Se_{fundtot} = 3 \cdot Ue_{fund} \cdot Ie_{fund}$$

Load unbalance

$$LU = \frac{Su_{fund}}{S_{tot}^+} \quad (38)$$

6.1.6 Classic Vector and Arithmetic Power measurement

Standard compliance: IEC 61557-12

See section 4.21.6 how to select Modern Power measurement method. Please note that instrument record all measurement (Classic and Modern), regardless of selected method.

Instrument fully complies with classic Vector and Arithmetic power measurement defined in the latest IEC 61557-12 standard (Annex A) and IEEE 1459 (Section 3.2.2.5 and 3.2.2.6). There is large number of measurement equipment installed on various points on network where this measurement algorithms are used for measurement and recording. In order to compare past measurement with current, use one of classic Power measurement. The measurements for active, reactive, and apparent powers have physical meaning as long as the current and voltage waveforms remained nearly sinusoidal. On figure below, graphical interpretation of Vector and Arithmetic power measurements are shown.

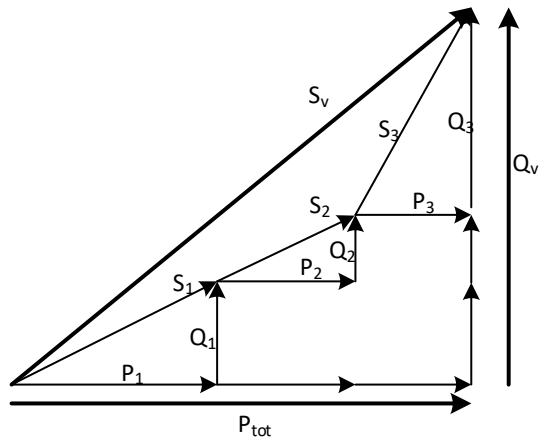

Figure 6.4: Vector representation of total power calculus

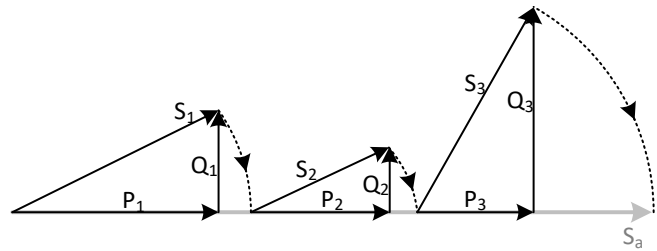

Figure 6.5: Arithmetic representation of total power calculus

In table below summary of all power measurement is shown.

Table 6.3: Summary and grouping of the phase power quantities

Quantity	Combined powers	Fundamental powers
Apparent (VA)	S	S _{fund}
Active (W)	P	P _{fund}
Nonactive/reactive (var)	N	Q _{fund}
Line utilization	PF _{ind/cap}	DPF _{ind/cap}

Table 6.4: Power summary and grouping of the total power quantities

Quantity	Combined powers	Fundamental powers
Apparent (VA)	S _v	S _{vfund}
Active (W)	P	P _{tot}
Nonactive/reactive (var)	N	Q _{tot}
Line utilization	PF _{vind/cap}	DPF _{v ind/cap}

6.1.6.1 Combined phase power measurements

All Classic combined phase power measurements are identical with Modern combined phase power measurement.

6.1.6.2 Total Vector combined power measurements

Standard compliance: IEC 61557-12 Annex A and IEEE STD 1459-2010 Section 3.2.2.6

Total Vector combined (fundamental + nonfundamental) active, nonactive and apparent power and total power factor are calculated according to the following equation:

$$\text{Total active power:} \quad P_{tot} = P_1 + P_2 + P_3 \quad [\text{W}], \quad (39)$$

$$\text{Total nonactive power (vector):} \quad N_{tot} = N_1 + N_2 + N_3 \quad [\text{var}], \quad (40)$$

$$\text{Total apparent power (vector):} \quad S_{V_{tot}} = \sqrt{P_{tot}^2 + N_{tot}^2} \quad [\text{VA}], \quad (41)$$

$$\text{Total power factor (effective):} \quad PF_{V_{tot}} = \frac{P_{tot}}{S_{V_{tot}}}. \quad (42)$$

6.1.6.3 Total Arithmetic combined power measurements

Standard compliance: IEC 61557-12 Annex A and IEEE STD 1459-2010 Section 3.2.2.5

Total Arithmetic combined (fundamental + nonfundamental) active, nonactive and apparent power and total power factor are calculated according to the following equation:

$$\text{Total active power:} \quad P_{tot} = P_1 + P_2 + P_3 \quad [\text{W}], \quad (43)$$

$$\text{Total apparent power (arithmetic):} \quad S_{a_{tot}} = S_1 + S_2 + S_3 \quad [\text{VA}], \quad (44)$$

$$\text{Total nonactive power (arithmetic):} \quad N_{a_{tot}} = \sqrt{S_{a_{tot}}^2 - P_{tot}^2} \quad [\text{var}], \quad (45)$$

$$\text{Total power factor (arithmetic):} \quad PF_{a_{tot}} = \frac{P_{tot}}{S_{a_{tot}}}. \quad (46)$$

6.1.6.4 Fundamental phase power measurements

Standard compliance: IEEE STD 1459-2010

All Classic fundamental phase power measurements are identical with Modern fundamental phase power measurement.

6.1.6.5 Total Vector fundamental power measurements

Standard compliance: IEC 61557-12 Annex A and IEEE STD 1459-2010 Section 3.2.2.6

Total Vector fundamental active, reactive and apparent power and total displacement vector power factor are calculated according to the following equation:

$$\text{Total fundamental active power:} \quad P_{fundtot} = P_{fund1} + P_{fund2} + P_{fund3} \quad [\text{W}], \quad (47)$$

$$\text{Total fundamental reactive power (vector): } Q_{fundtot} = Q_{fund1} + Q_{fund2} + Q_{fund3} \quad (48)$$

[var],

$$\text{Total fundamental apparent power (vector): } Sv_{fundtot} = \sqrt{P_{fundtot}^2 + Q_{fundtot}^2} \text{ [VA]}, \quad (49)$$

$$\text{Total displacement power factor (vector): } DPF_{v_{tot}} = \frac{P_{fundtot}}{Sv_{fundtot}}. \quad (50)$$

All fundamental power measurements are calculated from fundamental voltages and currents obtained from harmonic analysis (see section 6.1.8 for details).

6.1.6.6 Total Arithmetic fundamental power measurements

Standard compliance: IEC 61557-12 Annex A and IEEE STD 1459-2010 Section 3.2.2.5

Total Arithmetic fundamental active, reactive and apparent power and total displacement arithmetic power factor are calculated according to the following equation:

$$\text{Total fundamental active power: } P_{fundtot} = P_{fund1} + P_{fund2} + P_{fund3} \text{ [W]}, \quad (51)$$

$$\text{Total apparent power (arithmetic): } Sa_{fundtot} = S_{fund1} + S_{fund2} + S_{fund3} \text{ [VA]}, \quad (52)$$

$$\text{Total nonactive power (arithmetic): } Qa_{fundtot} = \sqrt{Sa_{fundtot}^2 - P_{fundtot}^2} \text{ [var]}, \quad (53)$$

$$\text{Total power factor (arithmetic): } DPF_{a_{tot}} = \frac{P_{fundtot}}{Sa_{fundtot}}. \quad (54)$$

All fundamental power measurements are calculated from fundamental voltages and currents obtained from harmonic analysis (see section 6.1.8 for details).

6.1.7 Energy

Standard compliance: IEC 62053-21 Class 2, IEC 62053-23 Class 3

Energy measurement is divided in two sections: ACTIVE energy based on active power measurement and REACTIVE energy, based on fundamental reactive power measurement. Each of them has two energy counters for consumed and generated energy.

Calculations are shown below:

Active energy:

$$\text{Consumed: } Ep_p^+ = \sum_{i=1}^m P_p^+(i)T(i) \text{ [kWh]}, p: 1,2,3, tot \quad (55)$$

$$\text{Generated: } Ep_p^- = \sum_{i=1}^m P_p^-(i)T(i) \text{ [kWh]}, p: 1,2,3, tot$$

Reactive energy:

$$\text{Consumed: } Eq_p^+ = \sum_{i=1}^m Q_{Ind}^+(i)T(i) + \sum_{i=1}^m Q_{pCap}^+(i)T(i) \text{ [kvarh], } p: 1,2,3, \text{ tot} \tag{56}$$

$$\text{Generated: } Eq_p^- = \sum_{i=1}^m Q_{pCap}^-(i)T(i) + \sum_{i=1}^m Q_{pInd}^-(i)T(i) \text{ [kvarh], } p: 1,2,3, \text{ tot}$$

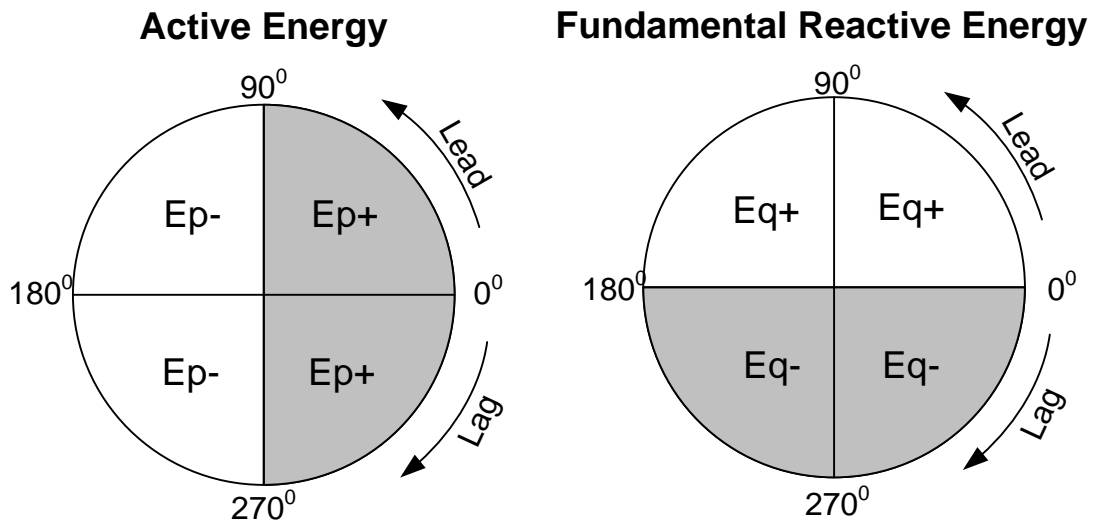

Figure 6.6: Energy counters and quadrant relationship

Instrument has 3 different counters sets:

1. Total counters are used for measuring energy over a complete recording. When recorder starts it sums the energy to existent state of the counters.
2. Last integration period counter measures energy during recording over last completed interval. It is calculated at end of each interval.
3. Current integration period counter measures energy during recording over current time interval.

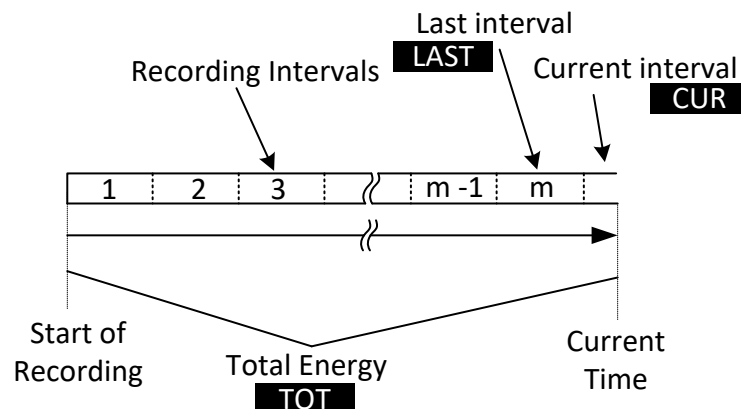

Figure 6.7: Instrument energy counters

6.1.8 Harmonics and interharmonics

Standard compliance: IEC 61000-4-30 Class S (Section 5.7)
IEC 61000-4-7 Class II

Calculation called fast Fourier transformation (FFT) is used to translate AD converted input signal to sinusoidal components. The following equation describes relation between input signal and its frequency presentation.

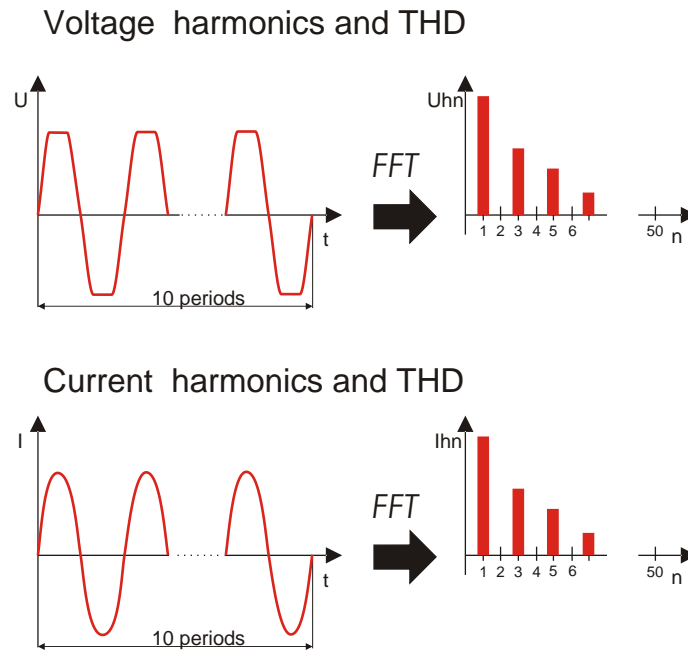

Figure 6.8: Current and voltage harmonics

$$u(t) = c_0 + \sum_{k=1}^{1024} c_k \sin\left(\frac{k}{10} \cdot 2\pi f_1 t + \varphi_k\right) \quad (57)$$

f_1 – frequency of signal fundamental (in example: 50 Hz)

c_0 – DC component

k – ordinal number (order of the spectral line) related to the frequency basis $f_{c1} = \frac{1}{T_N}$

T_N – is the width (or duration) of the time window ($T_N = N \cdot T_1$; $T_1 = 1/f_1$). Time window is that time span of a time function over which the Fourier transformation is performed.

c_k – is the amplitude of the component with frequency $f_{c_k} = \frac{k}{10} f_1$

φ_k – is the phase of the component c_k

$U_{c,k}$ – is the RMS voltage value of component c_k

$I_{c,k}$ – is the RMS current value of component c_k

Phase voltage and current harmonics are calculated as RMS value of harmonic subgroup (*sg*): square root of the sum of the squares of the RMS value of a harmonic and the two spectral components immediately adjacent to it.

$$n^{\text{th}} \text{ voltage harmonic: } U_p h_n = \sqrt{\sum_{k=-1}^1 U_{C,(10-n)+k}^2} \quad p: 1,2,3 \quad (58)$$

$$n^{\text{th}} \text{ current harmonic: } I_p h_n = \sqrt{\sum_{k=-1}^1 I_{C,(10-n)+k}^2} \quad p: 1,2,3 \quad (59)$$

Total harmonic distortion is calculated as ratio of the RMS value of the harmonic subgroups to the RMS value of the subgroup associated with the fundamental:

$$\text{Total voltage harmonic distortion: } THD_{U_p} = \sqrt{\sum_{n=2}^{40} \left(\frac{U_p h_n}{U_p h_1} \right)^2}, \quad p: 1,2,3 \quad (60)$$

$$\text{Total current harmonic distortion: } THD_{I_p} = \sqrt{\sum_{n=2}^{40} \left(\frac{I_p h_n}{I_p h_1} \right)^2}, \quad p: 1,2,3 \quad (61)$$

Spectral component between two harmonic subgroups are used for interharmonics assessment. Voltage and current interharmonic subgroup of n-th order is calculated using RSS (root sum square) principle:

$$n^{\text{th}} \text{ voltage interharmonic: } U_p i h_n = \sqrt{\sum_{k=2}^8 U_{C,(10-n)+k}^2} \quad p: 1,2,3 \quad (62)$$

$$n^{\text{th}} \text{ current interharmonic: } I_p i h_n = \sqrt{\sum_{k=2}^8 I_{C,(10-n)+k}^2} \quad p: 1,2,3 \quad (63)$$

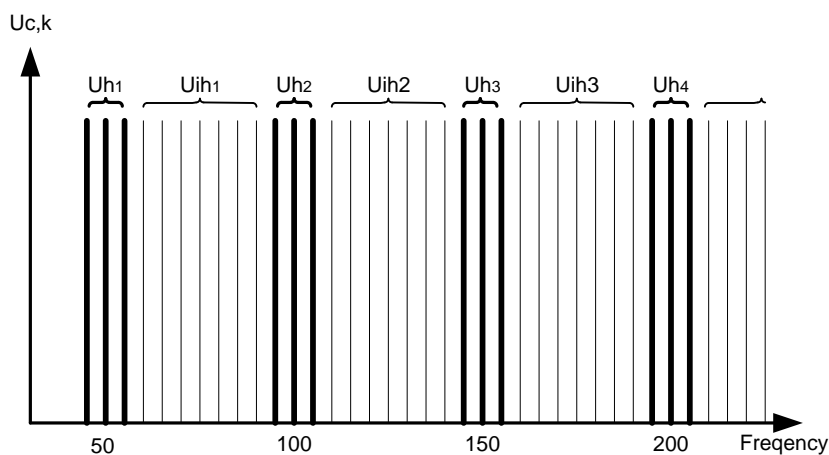

Figure 6.9: Illustration of harmonics / interharmonics subgroup for 50 Hz supply

The K factor is a factor that is developed to indicate the amount of harmonics that the load generates. The K rating is extremely useful when designing electric systems and sizing components. It is calculated as:

$$\text{K - factor: } K_p = \frac{\sum_{n=1}^{50} (I_p h_n \cdot n)^2}{\sum_{n=1}^{50} I_p h_n^2}, p: 1,2,3 \quad (64)$$

6.1.9 Signalling

Standard compliance: IEC 61000-4-30 Class S (Section 5.10)

Signalling voltage is calculated on a FFT spectrum of a 10/12-cycle interval. Value of mains signalling voltage is measured as:

- RMS value of a single frequency bin if signalling frequency is equal to spectral bin frequency, or
- RSS value of four neighbouring frequency bins if signalling frequency differs from the power system bin frequency (for example, a ripple control signal with frequency value of 218 Hz in a 50 Hz power system is measured based on the RMS values of 210, 215, 220 and 225 Hz bins).

Mains signalling value calculated every 10/12 cycle interval are used in alarm and recording procedures. However, for EN50160 recording, results are aggregated additionally on 3 s intervals. Those values are used for confronting with limits defined in standard.

6.1.10 Flicker

Standard compliance: IEC 61000-4-30 Class A (Section 5.3)

IEC 61000-4-15 Class F3

Flicker is a visual sensation caused by unsteadiness of a light. The level of the sensation depends on the frequency and magnitude of the lighting change and on the observer. Change of a lighting flux can be correlated to a voltage envelope on figure below.

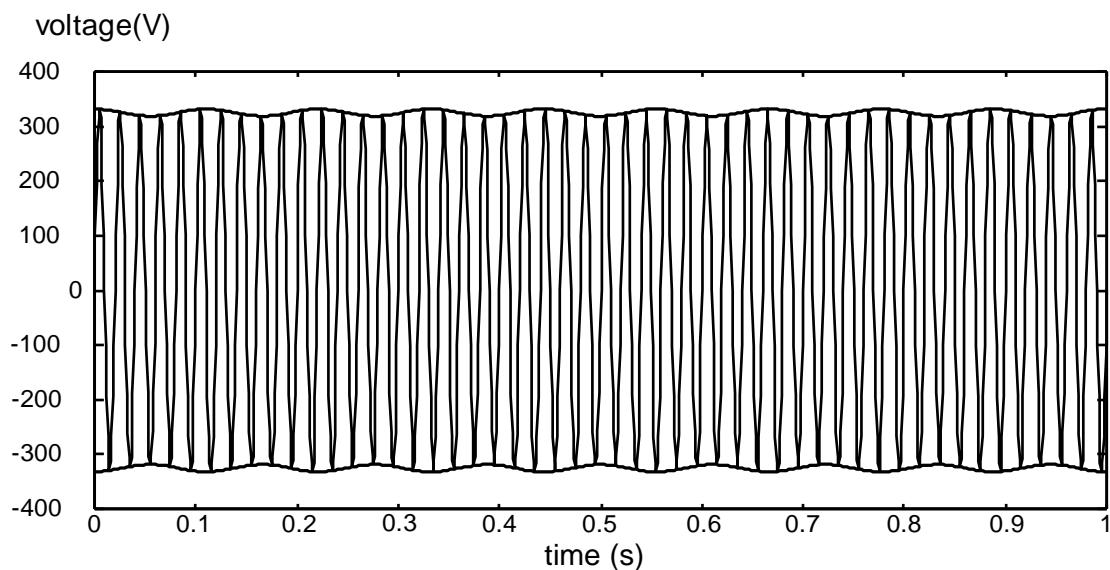

Figure 6.10: Voltage fluctuation

Flickers are measured in accordance with standard IEC 61000-4-15. Standard defines the transform function based on a 230 V / 60 W and 120 V / 60 W lamp-eye-brain chain response. That function is a base for flicker meter implementation and is presented on figure below.

P_{st1min} – is a short flicker estimation based on 1-minute interval. It is calculated to give quick preview of 10 minutes short term flicker.

P_{st} – 10 minutes, short term flicker is calculated according to IEC 61000-4-15

P_{lt} – 2 hours, long term flicker is calculated according to the following equation:

$$P_{ltp} = \sqrt[3]{\frac{\sum_{i=1}^N P_{st_i}^3}{N}} \quad p: 1,2,3 \quad (65)$$

6.1.11 Voltage and current unbalance

Standard compliance: IEC 61000-4-30 Class S (Section 5.7)

The supply voltage unbalance is evaluated using the method of symmetrical components. In addition to the positive sequence component U^+ , under unbalanced conditions there also exists negative sequence component U^- and zero sequence component U_0 . These quantities are calculated according to the following equations:

$$\begin{aligned} \vec{U}^+ &= \frac{1}{3}(\vec{U}_1 + a\vec{U}_2 + a^2\vec{U}_3) \\ \vec{U}_0 &= \frac{1}{3}(\vec{U}_1 + \vec{U}_2 + \vec{U}_3), \\ \vec{U}^- &= \frac{1}{3}(\vec{U}_1 + a^2\vec{U}_2 + a\vec{U}_3), \end{aligned} \quad (66)$$

where $a = \frac{1}{2} + \frac{1}{2}j\sqrt{3} = 1e^{j120^\circ}$.

For unbalance calculus, instrument use the fundamental component of the voltage input signals (U_1, U_2, U_3), measured over a 10/12-cycle time interval.

The negative sequence ratio u^- , expressed as a percentage, is evaluated by:

$$u^-(\%) = \frac{U^-}{U^+} \times 100 \quad (67)$$

The zero-sequence ratio u^0 , expressed as a percentage, is evaluated by:

$$u^0(\%) = \frac{U^0}{U^+} \times 100 \quad (68)$$

Note: In 3W systems zero sequence components U_0 and I_0 are by definition zero.

The supply current unbalance is evaluated in same fashion.

6.1.12 Underdeviation and overdeviation

Voltage Underdeviation (U_{Under}) and Overdeviation (U_{Over}) measurement method: Standard compliance: IEC 61000-4-30 Class A (Section 5.12)

Basic measurement for the Underdeviation and Overdeviation is RMS voltage magnitude measured over a 10/12-cycle time interval. Each RMS voltage *magnitude* (*i*) obtained through recording campaign is compared to nominal voltage U_{Nom} from which we express two vectors according to the formulas below:

$$U_{Under,i} = \begin{cases} U_{RMS(10/12),i} & \text{if } U_{RMS(10/12)} \leq U_{Nom} \\ U_{Nom} & \text{if } U_{RMS(10/12)} > U_{Nom} \end{cases} \quad (69)$$

$$U_{Over,i} = \begin{cases} U_{RMS(10/12),i} & \text{if } U_{RMS(10/12)} \geq U_{Nom} \\ U_{Nom} & \text{if } U_{RMS(10/12)} < U_{Nom} \end{cases} \quad (70)$$

Aggregation is performed on the end of recording interval as:

$$U_{Under} = \frac{U_{Nom} - \sqrt{\frac{\sum_{i=1}^n U_{Under,i}^2}{n}}}{U_{Nom}} [\%] \quad (71)$$

$$U_{Over} = \frac{U_{Nom} - \sqrt{\frac{\sum_{i=1}^n U_{Over,i}^2}{n}}}{U_{Nom}} [\%] \quad (72)$$

Underdeviation and overdeviation parameters may be useful when it is important to avoid, for example, having sustained undervoltages being cancelled in data by sustained overvoltages.

Note: Underdeviation and Overdeviation parameters are always positive values.

6.1.13 Voltage events

6.1.13.1 Measurement method

Standard compliance: IEC 61000-4-30 Class S (Section 5.4)

The basic measurement for event is $U_{Rms(1/2)}$. $U_{Rms(1/2)}$ is value of the RMS voltage measured over 1 cycle, commencing at a fundamental zero crossing and refreshed each half-cycle.

The cycle duration for $U_{Rms(1/2)}$ depends on the frequency, which is determined by the last 10/12-cycle frequency measurement. The $U_{Rms(1/2)}$ value includes, by definition, harmonics, interharmonics, mains signalling voltage, etc.

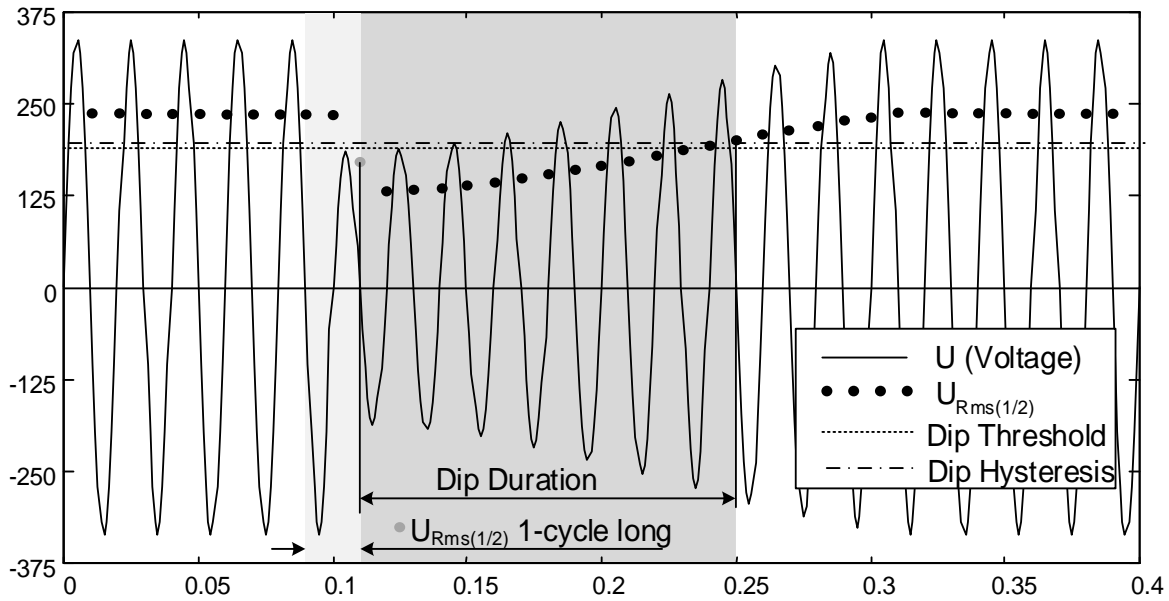

Figure 6.11: $U_{Rms(1/2)}$ 1-cycle measurement

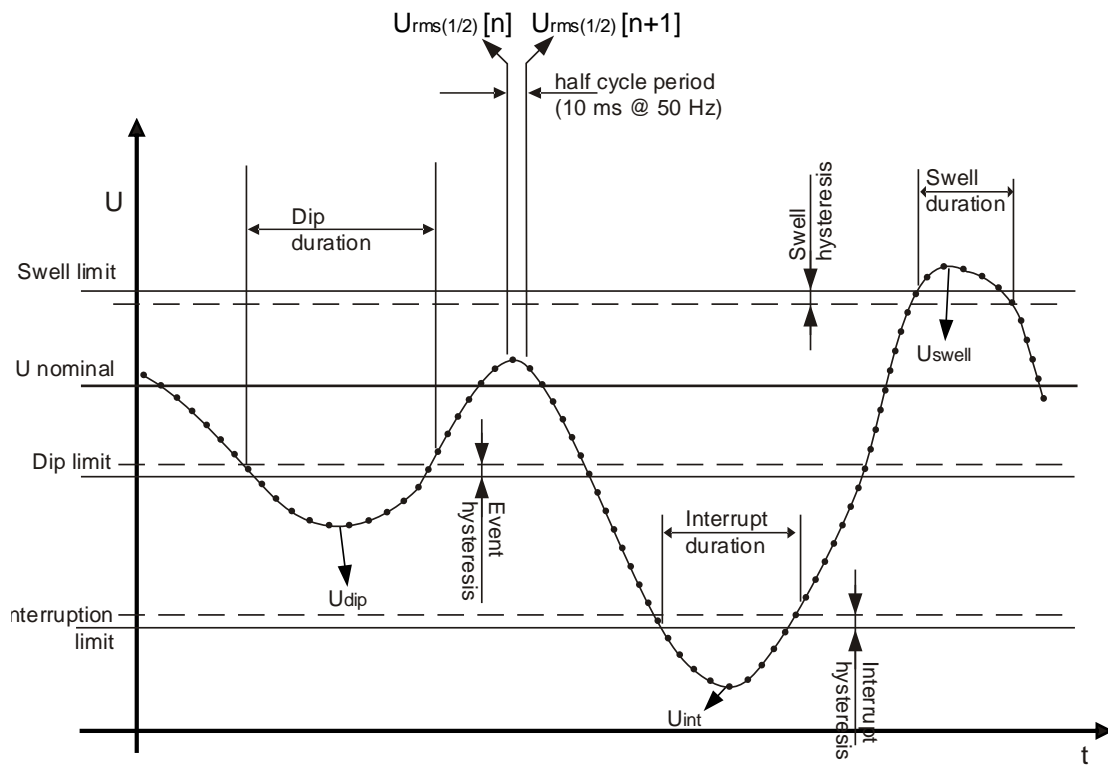

Figure 6.12 Voltage events definition

6.1.13.2 Voltage dip

Standard compliance: IEC 61000-4-30 Class S (Sections 5.4.1 and 5.4.2)

The **Dip Threshold** is a percentage of Nominal voltage defined in CONNECTION menu. The Dip Threshold and Hysteresis can be set by the user according to the use. **Dip Hysteresis** is difference in magnitude between the Dip start and Dip end thresholds. Instrument event evaluation in Event table screen depends on Connection type:

- On single-phase system (Connection type: 1W), a voltage dip begins when the $U_{Rms(1/2)}$ voltage falls below the dip threshold, and ends when the $U_{Rms(1/2)}$ voltage is equal to or above the dip threshold plus the hysteresis voltage (see Figure 6.12 and Figure 6.11),.
- On poly-phase systems (Connection type: 2W, 3W, 4W, Open Delta) two different views can be used for evaluation simultaneously:
 - Group view  with selected **ALL INT** view (in compliance with IEC 61000-4-30 Class S): a dip begins when the $U_{Rms(1/2)}$ voltage of one or more channels is below the dip threshold and ends when the $U_{Rms(1/2)}$ voltage on all measured channels is equal to or above the dip threshold plus the hysteresis voltage.
 - Phase view **Ph.** (for troubleshooting): a voltage dip begins when the $U_{Rms(1/2)}$ voltage of one channel falls below the dip threshold, and ends when the $U_{Rms(1/2)}$ voltage is equal to or above the dip threshold plus the hysteresis voltage, on the same phase.



Figure 6.13: Voltage dip related screens on the instrument

A voltage dip is characterized by following data: **Dip Start time**, Level (U_{Dip}) and **Dip duration**:

- U_{Dip} – residual dip voltage, is the lowest $U_{Rms(1/2)}$ value measured on any channel during the dip. It is shown in **Level** column in the Event Table on the instrument.
- The **Dip Start time** is time stamped with the time of the start of the $U_{Rms(1/2)}$ of the channel that initiated the event. It is shown in **START** column in the Event Table on the instrument. The Dip End time is time stamped with the time of the end of the $U_{Rms(1/2)}$ that ended the event, as defined by the threshold.
- The **Dip Duration** is the time difference between the Dip Start time and the Dip End time. It is shown in **Duration** column in the Event Table on the instrument.

6.1.13.3 Voltage swell

Standard compliance: IEC 61000-4-30 Class S (Sections 5.4.1 and 5.4.3)

The **Swell Threshold** is a percentage of nominal voltage defined in CONNECTION menu. The swell threshold can be set by the user according to the use. **Swell Hysteresis** is difference in magnitude between the Swell start and Swell end thresholds. Instrument event evaluation in Event table screen depends on Connection type:

- On single-phase system (Connection type: 1W) , a voltage swell begins when the $U_{Rms(1/2)}$ voltage rises above the swell threshold, and ends when the $U_{Rms(1/2)}$ voltage is equal to or below the swell threshold plus the hysteresis voltage (see Figure 6.12 and Figure 6.11),
- On poly-phase systems (Connection type: 2W, 3W, 4W, Open Delta) two different view can be used for evaluation simultaneously:
 - Group view  with selected **ALL INT** view: A swell begins when the $U_{Rms(1/2)}$ voltage of one or more channels is above the swell threshold and ends when the $U_{Rms(1/2)}$ voltage on all measured channels is equal to or below the swell threshold plus the hysteresis voltage.
 - Phase view **Ph.**: A swell begins when the $U_{Rms(1/2)}$ voltage of one channel rises above the swell threshold, and ends when the $U_{Rms(1/2)}$ voltage is equal to or below the swell threshold plus the hysteresis voltage, on the same phase.

A voltage swell is characterized by following data: **Swell Start time**, Level (U_{Swell}) and **Swell duration**:

- U_{Swell} – maximum swell magnitude voltage, is the largest $U_{Rms(1/2)}$ value measured on any channel during the swell. It is shown in **Level** column in the Event Table on the instrument.
- The **Swell Start time** is time stamped with the time of the start of the $U_{Rms(1/2)}$ of the channel that initiated the event. It is shown in **START** column in the Event Table on the instrument. The Swell End time is time stamped with the time of the $U_{Rms(1/2)}$ that ended the event, as defined by the threshold.
- The **Duration** of a voltage swell is the time difference between the beginning and the end of the swell. It is shown in **Duration** column in the Event Table on the instrument.

6.1.13.4 Voltage interrupt

Standard compliance: IEC 61000-4-30 Class S (Section 5.5)

Measuring method for voltage interruptions detection is same as for dips and swells, and is described in previous sections.

The **Interrupt Threshold** is a percentage of nominal voltage defined in CONNECTION menu. **Interrupt Hysteresis** is difference in magnitude between the Interrupt start and Interrupt end thresholds. The interrupt threshold can be set by the user according to the use. Instrument event evaluation in Event table screen depends on Connection type:

- On single-phase system (1W), a voltage interruption begins when the $U_{Rms(1/2)}$ voltage falls below the voltage interruption threshold and ends when the $U_{Rms(1/2)}$ value is equal to, or greater than, the voltage interruption threshold plus the hysteresis (see Figure 6.12 and Figure 6.11),
- On poly-phase systems (2W, 3W, 4W, Open Delta) two different view can be used for evaluation simultaneously:
 - Group view  with selected **ALL INT** view: a voltage interruption begins when the $U_{Rms(1/2)}$ voltages of all channels fall below the voltage interruption threshold and ends when the $U_{Rms(1/2)}$ voltage on any one channel is equal to, or greater than, the voltage interruption threshold plus the hysteresis.
 - Phase view **Ph.**: a voltage interrupt begins when the $U_{Rms(1/2)}$ voltage of one channel fall below the interrupt threshold, and ends when the $U_{Rms(1/2)}$ voltage is equal to or above the interrupt threshold plus the hysteresis voltage, on the same phase.



Figure 6.14: Voltage interrupts related screens on the instrument

A voltage interrupt is characterized by following data: **Interrupt Start time**, **Level (U_{Int})** and **Interrupt Duration**:

- U_{Int} – minimum interrupt magnitude voltage, is the lower $U_{Rms(1/2)}$ value measured on any channel during the interrupt. It is shown in **Level** column in the Event Table on the instrument.
- The **Interrupt Start time** of a interrupt is time stamped with the time of the start of the $U_{Rms(1/2)}$ of the channel that initiated the event. It is shown in **START** column in the Event Table on the instrument. The Interrupt End time of the interrupt is time stamped with the time of the end of the $U_{Rms(1/2)}$ that ended the event, as defined by the threshold.
- The **Interrupt Duration** is the time difference between the beginning and the end of the interrupt. It is shown in **Duration** column in the Event Table on the instrument.

6.1.14 Alarms

Generally, alarm can be seen as an event on arbitrary quantity. Alarms are defined in alarm table (see section 4.21.3 for alarm table setup). The basic measurement time interval for: voltage, current, active, nonactive and apparent power, harmonics and unbalance alarms is a 10/12-cycle time interval.

Each alarm has attributes described in table below. Alarm occurs when 10/12-cycle measured value on phases defined as **Phase**, cross **Threshold value** according to defined **Trigger slope**, minimally for **Minimal duration** value.

Table 6.5: Alarm definition parameters

Quantity	<ul style="list-style-type: none"> • Voltage • Current • Frequency • Active, nonactive and apparent power • Harmonics and interharmonics • Unbalance • Flickers • Signalling
Phase	L1, L2, L3, L12, L23, L31, All, Tot, N

Trigger slope	< - Fall, > - Rise
Threshold value	[Number]
Minimal duration	200ms ÷ 10min

Each captured alarm is described by the following parameters:

Table 6.6: Alarm signatures

Date	Date when selected alarm has occurred
Start	Alarm start time - when first value cross threshold.
Phase	Phase on which alarm occurred
Level	Minimal or maximal value in alarm
Duration	Alarm duration

6.1.15 Rapid voltage changes (RVC)

Standard compliance: IEC 61000-4-30 Class S (Section 5.11)

Rapid Voltage Change (RVC) is generally speaking an abrupt transition between two “steady state” RMS voltage levels. It is considered as event, (similar to dip or swell) with start time and duration between steady state levels. However, those steady state levels does not exceed dip or swell threshold.

6.1.15.1 RVC event detection

Instrument RVC event detection implementation strictly follows IEC 61000-4-30 standard requirements. It begins with finding a voltage steady-state. RMS voltage is in a steady-state condition if 100/120 $U_{Rms(1/2)}$ values remain within an *RVC threshold* (this value is set by the user in MEASUREMENT SETUP → RVC Setup screen) from the arithmetic mean of those 100/120 $U_{Rms(1/2)}$ values. Every time a new $U_{Rms(1/2)}$ value is available, the arithmetic mean of the previous 100/120 $U_{Rms(1/2)}$ values, including the new value, is calculated. If a new $U_{Rms(1/2)}$ value crosses *RVC threshold*, RVC event is detected. After detection instruments wait for 100/120 half cycles, before searching for next voltage steady-state.

If a voltage dip or voltage swell is detected during an RVC event, then the RVC event is discarded because the event is not an RVC event.

6.1.15.2 RVC event characterisation

An RVC event is characterized by four parameters: start time, duration, ΔU_{max} and ΔU_{ss} .

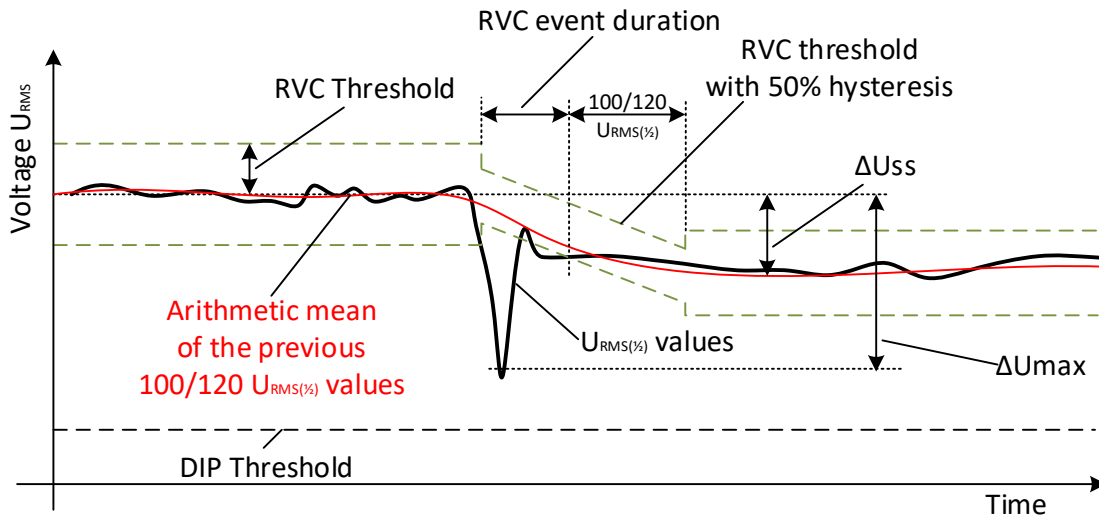

Figure 6.15: RVC event description

- **Start time** of an RVC event is time stamp when $U_{Rms(1/2)}$ value cross *RVC threshold* level
- RVC event **duration** is 100/120 half cycles shorter than the duration between adjacent steady states voltages.
- **ΔU_{max}** is the maximum absolute difference between any of the $U_{Rms(1/2)}$ values during the RVC event and the final arithmetic mean 100/120 $U_{Rms(1/2)}$ value just prior to the RVC event. For poly-phase systems, the ΔU_{max} is the largest ΔU_{max} on any channel.
- **ΔU_{ss}** is the absolute difference between the final arithmetic mean 100/120 $U_{Rms(1/2)}$ value just prior to the RVC event and the first arithmetic mean 100/120 $U_{Rms(1/2)}$ value after the RVC event. For poly-phase systems, the ΔU_{ss} is the largest ΔU_{ss} on any channel.

6.1.16 Data aggregation in GENERAL RECORDING

Standard compliance: IEC 61000-4-30 Class S (Section 4.5)

Time aggregation period (IP) during recording is defined with parameter `Interval: x min` in GENERAL RECORDER menu.

A new recording interval commence at real time clock tick (10 minutes \pm half cycle, for `Interval: 10 min`) and it last until next real time clock plus time needed to finish current 10/12 cycle measurement. In the same time new measurement is started, as shown on next figure. The data for the IP time interval are aggregated from 10/12-cycle time intervals, according to the figure below. The aggregated interval is tagged with the absolute time. The time tag is the time at the conclusion of the interval. There is overlap, during recording, as illustrated on figure below.

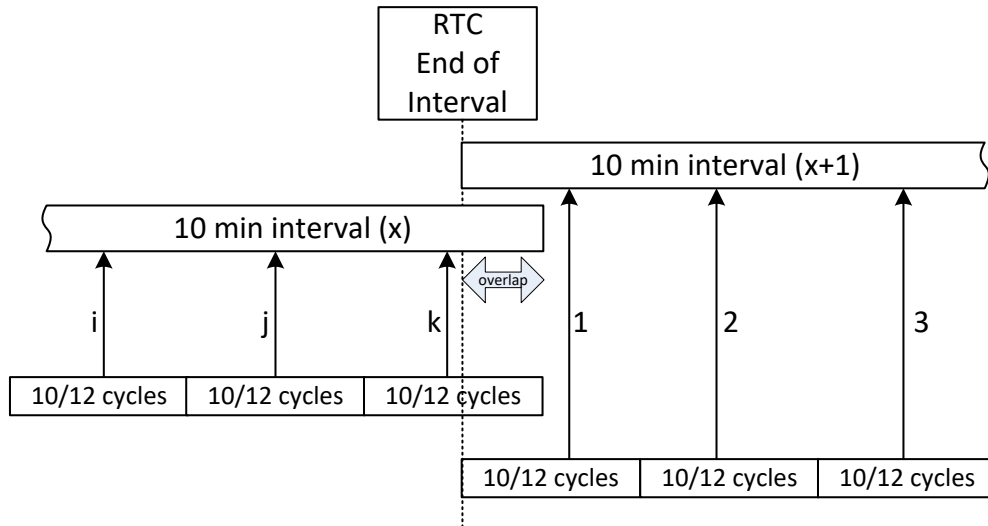

Figure 6.16: Synchronization and aggregation of 10/12 cycle intervals

Depending from the quantity, for each aggregation interval instrument computes average, minimal, maximal and/or active average value., this can be RMS (root means square) or arithmetical average. Equations for both averages are shown below.

RMS average
$$A_{RMS} = \sqrt{\frac{1}{N} \sum_{j=1}^N A_j^2}$$
 (73)

Where:

A_{RMS} – quantity average over given aggregation interval

A – 10/12-cycle quantity value

N – number of 10/12 cycles measurements per aggregation interval.

Arithmetic average:
$$A_{avg} = \frac{1}{N} \sum_{j=1}^N A_j$$
 (74)

Where:

A_{avg} – quantity average over given aggregation interval

A – 10/12-cycle quantity value

N – number of 10/12 cycles measurements per aggregation interval.

In the next table averaging method for each quantity is specified:

Table 6.7: Data aggregation methods

Group	Value	Aggregation method	Recorded values
Voltage	U_{Rms}	RMS average	Min, Avg, Max
	THD_U	RMS average	Avg, Max
	CF_U	RMS average	Min, Avg, Max
Current	I_{Rms}	RMS average	Min, Avg, AvgOn, Max
	THD_I	RMS average	Min, Avg, AvgOn, Max

	CF _I	RMS average	Min, Avg, AvgOn, Max
Frequency	f(10s)	-	
	f(200ms)	RMS average	Min, AvgOn, Max
Power	Combined	Arithmetic average	Min, Avg, AvgOn, Max
	Fundamental	Arithmetic average	Min, Avg, AvgOn, Max
	Nonfundamental	Arithmetic average	Min, Avg, AvgOn, Max
Unbalance	U ⁺	RMS	Min, Avg, Max
	U ⁻	RMS	Min, Avg, Max
	U ⁰	RMS	Min, Avg, Max
	u ⁻	RMS	Min, Avg, Max
	u ⁰	RMS	Min, Avg, Max
	I ⁺	RMS	Min, Avg, AvgOn, Max
	I ⁻	RMS	Min, Avg, AvgOn, Max
	I ⁰	RMS	Min, Avg, AvgOn, Max
	i ⁻	RMS	Min, Avg, AvgOn, Max
	i ⁰	RMS	Min, Avg, AvgOn, Max
Harmonics	DC, U _{h0÷50}	RMS	Avg, Max
	DC, I _{h0÷50}	RMS	Avg, AvgOn, Max
Interharmonics	U _{h0÷50}	RMS	Avg, Max
	I _{h0÷50}	RMS	Avg, AvgOn, Max
Signalling	U _{Sig}	RMS	Min, Avg, Max

An *active average* value is calculated upon the same principle (arithmetic or RMS) as average value, but taking in account only measurement where measured value is not zero:

$$\text{RMS active average} \quad A_{RMSact} = \sqrt{\frac{1}{M} \sum_{j=1}^M A_j^2}; M \leq N \quad (75)$$

Where:

A_{RMSact} – quantity average over active part of given aggregation interval,

A – 10/12-cycle quantity value marked as “active”,

M – number of 10/12 cycles measurements with active (non-zero) value.

$$\text{Arithmetic active average:} \quad A_{avgact} = \frac{1}{M} \sum_{j=1}^M A_j; M \leq N \quad (76)$$

Where:

A_{avgact} – quantity average over active part of given aggregation interval,

A – 10/12-cycle quantity value in “active” part of interval,

M – number of 10/12 cycles measurements with active (non-zero) value.

6.1.16.1 Difference between standard average (Avg) and active average (AvgOn)

Example: Suppose we measure current on AC motor which is switched on for 5 min every 10 minutes. Motor consumes 100A. User set recording interval to 10 minutes.

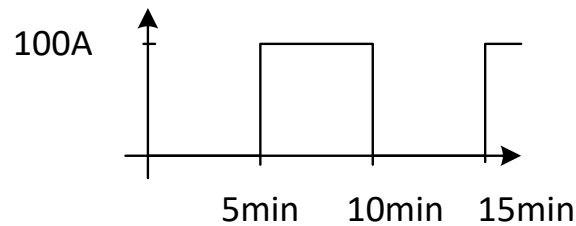

Figure 6.17: Avg vs. Avgon, switching load current

After 10 minutes values will be:

I_{rms} (rms average) = 50A

I_{rms} (rms AvgOn) = 100A

AvgOn considers only those measurements where current is greater than zero.

6.1.16.2 Power and energy recording

Active power is aggregated into two different quantities: import (positive-consumed P+) and export (negative-generated P-). Nonactive power and power factor are aggregated into four parts: positive inductive (i+), positive capacitive (c+), negative inductive (i-) and negative capacitive (c-).

Consumed/generated and inductive/capacitive phase/polarity diagram is shown on figure below:

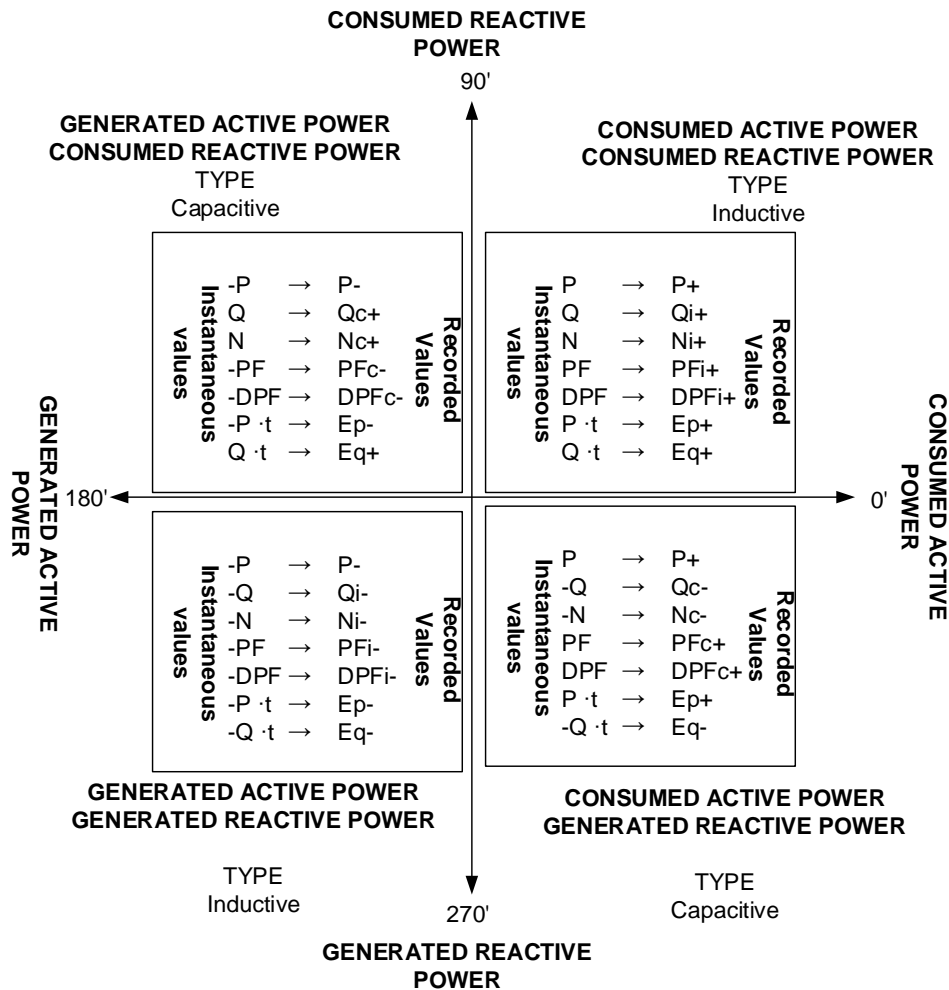

Figure 6.18: Consumed/generated and inductive/capacitive phase/polarity diagram

6.1.17 Flagged data

Standard compliance: IEC 61000-4-30 Class A (Section 4.7)

During a dip, swell, or interruption, the measurement algorithm for other parameters (for example, frequency measurement) might produce an unreliable value. The flagging concept avoids counting a single event more than once in different parameters (for example, counting a single dip as both a dip and a voltage variation), and indicates that an aggregated value might be unreliable.

Flagging is only triggered by dips, swells, and interruptions. The detection of dips and swells is dependent on the threshold selected by the user, and this selection will influence which data are "flagged".

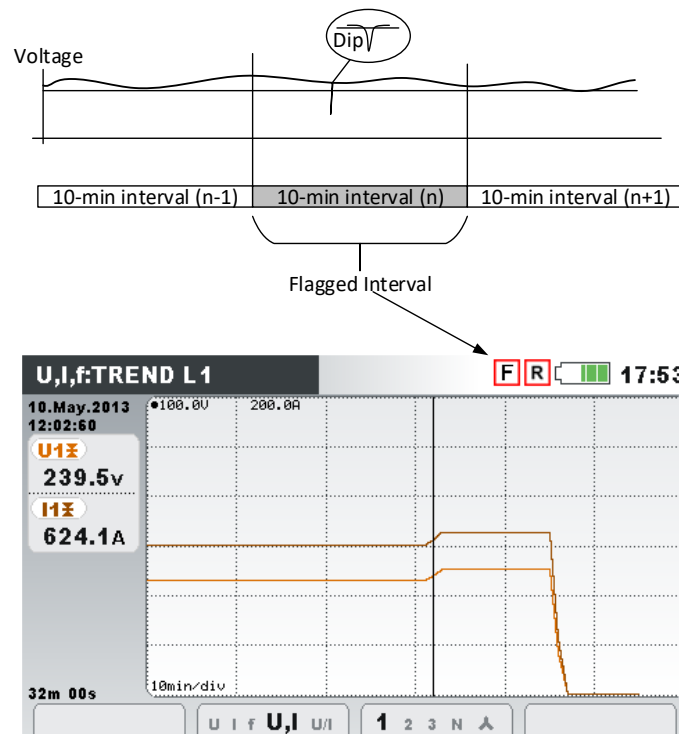



Figure 6.19: Flagging data indicate that aggregated value might be unreliable

6.1.18 Waveform snapshot

During measurement campaign Energy Master XA/Energy Master has the ability to take waveform snapshot. This is particularly useful for storing temporary characteristics or network behaviour. Snapshot stores all network signatures and waveform samples for 10/12 cycles. Using MEMORY LIST function (see 4.19) or with PowerView v3.0 software, user can observe stored data. Waveform snapshot is captured by starting GENERAL recorder or by pressing  for 3 seconds in any of MEASUREMENTS sub screens.



Long press on  triggers WAVEFORM SNAPSHOT. Instrument will record all measured parameters into file.

Note: WAVEFORM SNAPSHOT is automatically created at the start of GENERAL RECORDER.

6.1.19 Waveform recorder (available at Energy Master XA)

Waveform recorder can be used in order to capture waveform of particular network event: such as voltage event, inrush or alarm. In waveform record samples of voltage and current are stored for given duration. Waveform recorder starts when the pre-set trigger occurs. Storage buffer is divided into pre-trigger and post-trigger buffers. Pre- and post-trigger buffers are composed of waveform snapshots taken before and after trigger occurrence, as shown on following figure.

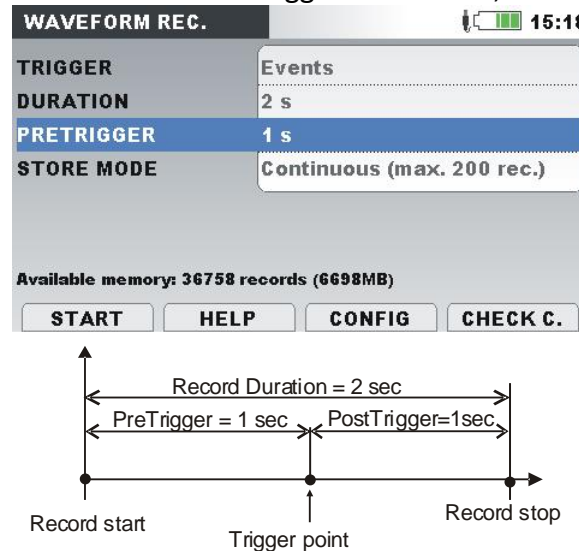

Figure 6.20: Triggering and pre-triggering description

Several trigger sources are possible:

- Manual trigger - user manually triggers waveform recording.
- Voltage events – instrument starts waveform recorder when voltage event occur. Voltage events are set up in EVENT SETUP menu (see 4.21.2 for details), where user defines threshold limits for each event type: Dip, Swell and Interrupt. Each time event occurs, waveform recorder starts recording. Instrument then capture URms(1/2) and IRms(1/2) values into RxxxINR.REC file and waveform samples for all voltages and currents channels into RxxxWAV.REC file. If parameter PRETRIGGER is greater than zero, then recoding will start prior the event for defined time, and will finish when record DURATION length is reached. On following figure voltage dip is shown, where voltage drops from nominal value to the almost zero. When voltage drops below dip threshold, it triggers recorder, which capture voltage and current samples from one second before dip to one second after dip occurs. Note that if during this time period another event occurs, (as interrupt on figure below, for example) it will be captured within the same file. In case where voltage event last for longer time, new recording will start after first record is finished, soon as any new event occurs (voltage ramp-up event, shown as example on figure below).

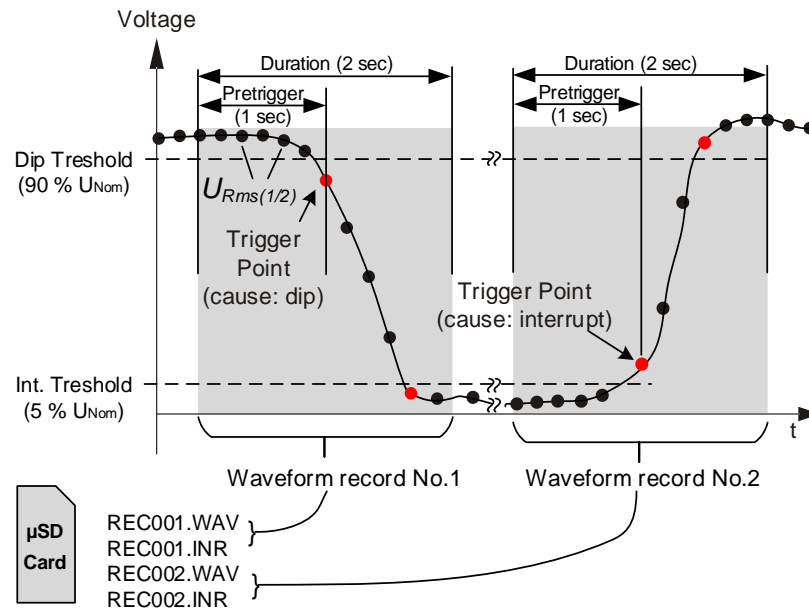

Figure 6.21: Voltage Event Triggering

- Voltage level – instrument starts waveform recorder when measured RMS voltage reaches given voltage threshold.

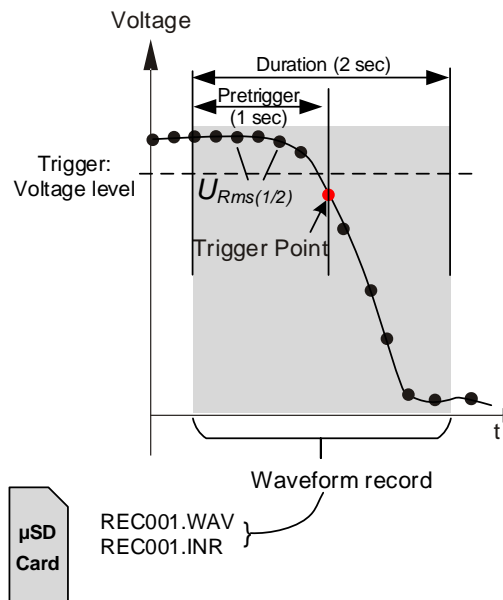

Figure 6.22: Voltage Level Triggering

- Current level - instrument starts waveform recorder when measured current reaches given current threshold. Typically, this type of triggering is used for capturing inrush currents.

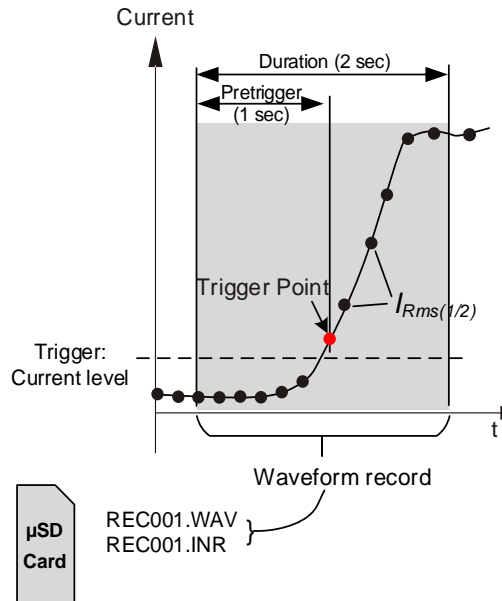

Figure 6.23: Current Level Triggering (Inrush)

- Alarms – instrument starts waveform recorder when any alarm from alarm list is detected. In order to see how to setup Alarm Table, please check section 4.21.3.
- Voltage events and alarms – instrument starts waveform recorder when either voltage event or alarm occur.
- Interval – instrument starts waveform recorder periodically, each time after given time interval Interval: 10min finish.
- User can perform single or continuous waveform recordings up to 200 records. In continuous waveform recording, Power Master will automatically initialize next waveform recording upon completion of the previous one.

6.1.19.1 Voltage event trigger

Waveform recorder can be set up to trigger on voltage events as shown on figure below.

EVENT SETUP		
Nominal voltage L-N = 230V		
Swell Threshold	110.0%	(253.0V)
Swell Hysteresis	2%	
Dip Threshold	90.0%	(207.0V)
Dip Hysteresis	2%	
Interrupt Threshold	5.0%	(11.5V)
Interrupt Hysteresis	2%	
HELP		

Figure 6.24: Waveform recorder setup for triggering on voltage events

6.1.19.2 Inrush recorder

In addition to the waveform record which represent voltage samples, instrument also store RMS voltage $U_{Rms(1/2)}$ and current $I_{Rms(1/2)}$. This type of record is particularly suitable for capturing motor inrush. It gives analysis of voltage and current fluctuations during start of motor or other

high-power consumers. For current $I_{Rms(1/2)}$ value (half cycle period RMS current refreshed each half cycle) is measured, while for voltage $U_{Rms(1/2)}$ values (one cycle RMS voltage refreshed each half cycle) is measured for each interval. In following figures, Level triggering is shown.

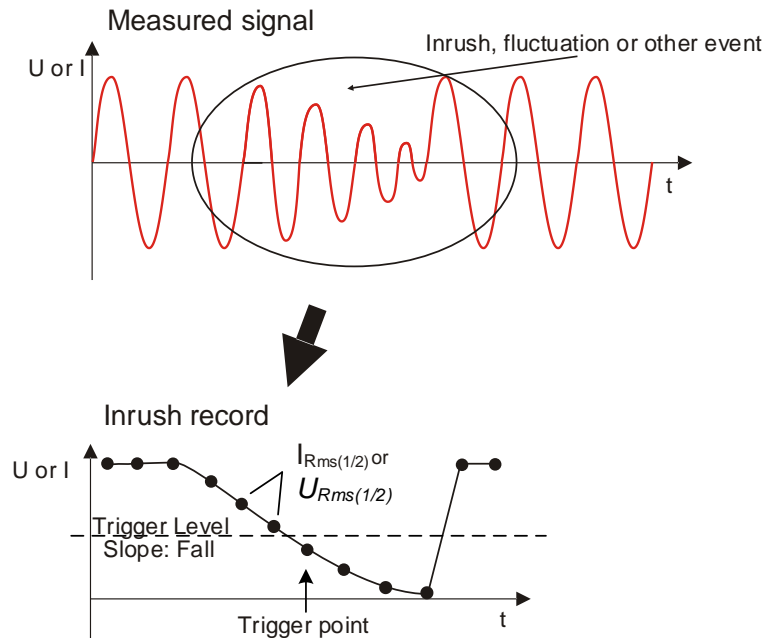

Figure 6.25: Level triggering

Triggering slope

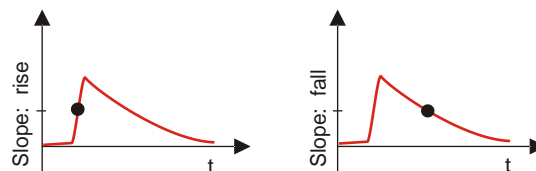

Figure 6.26: Triggering slope

6.1.20 Transient recorder

Transient recorder is similar to waveform recorder. It stores a selectable set of pre- and post-trigger samples on trigger activation, but with 10 times higher sampling rate.

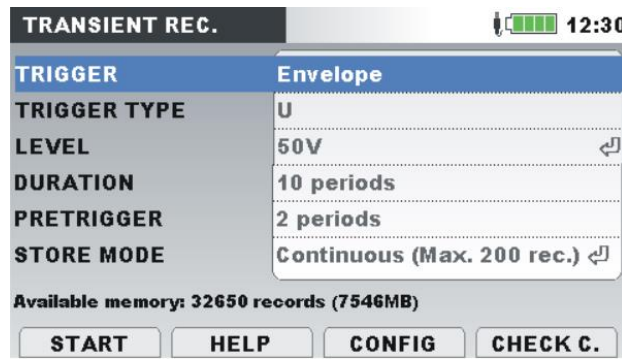

Figure 6.27: Transient recorder setup for triggering on voltage events

Recorder can be triggered on envelope or level.

Envelope trigger is activated if difference between same samples on two consecutive periods of triggering signal, is greater than given limit.

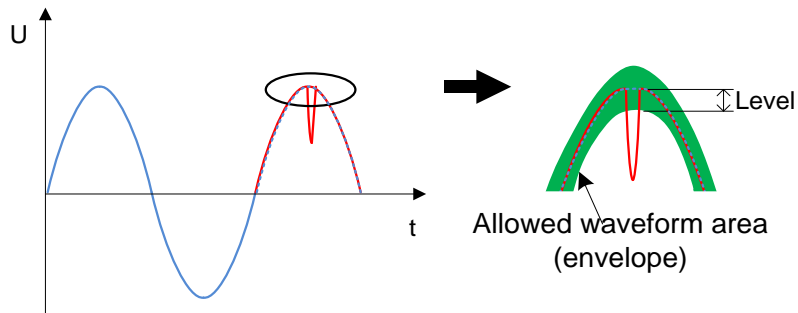

Figure 6.28: Transients trigger detection (envelope)

Level trigger is activated if sampled voltage/current is greater than given limit.

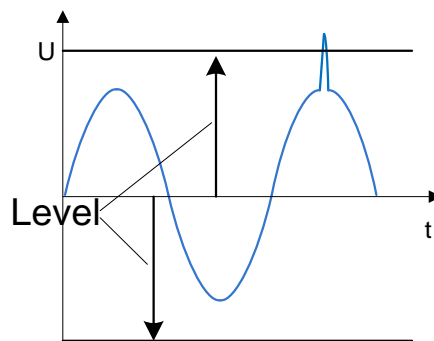

Figure 6.29: Transients trigger detection (envelope)

Note: Saving to the instrument data memory induces dead time between consecutive transient records. Dead time is proportional to record duration, and in worst case for 50 sec long transient it will take 4 seconds, before new transient can be captured.

6.2 EN 50160 Standard Overview

EN 50160 standard defines, describes and specifies the main characteristics of the voltage at a network user's supply terminals in public low voltage and medium voltage distribution networks under normal operating conditions. This standard describes the limits or values within which the voltage characteristics can be expected to remain over the whole of the public distribution network and do not describe the average situation usually experienced by an individual network user. An overview of EN 50160 Low voltage limits are presented on table below.

Table 6.8: EN 50160 standard LV limits (continuous phenomena)

Supply voltage phenomenon	Acceptable limits	Meas. Interval	Monitoring Period	Acceptance Percentage
Power frequency	49.5 ÷ 50.5 Hz 47.0 ÷ 52.0 Hz	10 s	1 Week	99,5% 100%
Supply voltage variations, U_{Nom}	230V ± 10% 230V +10% -15%	10 min	1 Week	95% 100%
Flicker severity Plt	Plt ≤ 1	2 h	1 Week	95%
Voltage unbalance u-	5 ÷ 2 %, occasionally 3%	10 min	1 Week	95%
Total harm. Distortion, THD _U	8%	10 min	1 Week	95%
Harmonic Voltages, U_{h_n}	See Table 6.9	10 min	1 Week	95%
Mains signalling	See Figure 6.30	2 s	1 Day	99%

6.2.1 Power frequency

The nominal frequency of the supply voltage shall be 50 Hz, for systems with synchronous connection to an interconnected system. Under normal operating conditions the mean value of the fundamental frequency measured over 10 s shall be within a range of:

50 Hz ± 1 % (49,5 Hz ... 50,5 Hz) during 99,5 % of a year;

50 Hz + 4 % / - 6 % (i.e. 47 Hz ... 52 Hz) during 100 % of the time.

6.2.2 Supply voltage variations

Under normal operating conditions, during each period of one week 95 % of the 10 min mean U_{Rms} values of the supply voltage shall be within the range of $U_{Nom} \pm 10 \%$, and all U_{Rms} values of the supply voltage shall be within the range of $U_{Nom} + 10 \%$ / - 15 %.

6.2.3 Supply voltage unbalance

Under normal operating conditions, during each period of one week, 95 % of the 10 min mean RMS values of the negative phase sequence component (fundamental) of the supply voltage shall be within the range 0 % to 2 % of the positive phase sequence component (fundamental). In some areas with partly single phase or two-phase connected network users' installations, unbalances up to about 3 % at three-phase supply terminals occur.

6.2.4 THD voltage and harmonics

Under normal operating conditions, during each period of one week, 95 % of the 10 min mean values of each individual harmonic voltage shall be less or equal to the value given in table below. Moreover, THD_U values of the supply voltage (including all harmonics up to the order 40) shall be less than or equal to 8 %.

Table 6.9: Values of individual harmonic voltages at the supply

Odd harmonics				Even harmonics	
Not Multiples of 3		Multiples of 3		Order h	Relative voltage (U _N)
Order h	Relative voltage (U _N)	Order h	Relative voltage (U _N)		
5	6,0 %	3	5,0 %	2	2,0 %
7	5,0 %	9	1,5 %	4	1,0 %
11	3,5 %	15	1,0 %	6..24	0,5 %
13	3,0 %	21	0,75 %		
17	2,0 %				
19	1,5 %				
23	1,5 %				
25	1,5 %				

6.2.5 Interharmonic voltage

The level of interharmonics is increasing due to the development of frequency converters and similar control equipment. Levels are under consideration, pending more experience. In certain cases, interharmonics, even at low levels, give rise to flickers (see 6.2.7), or cause interference in ripple control systems.

6.2.6 Mains signalling on the supply voltage

In some countries the public distribution networks may be used by the public supplier for the transmission of signals. Over 99 % of a day the 3 s mean of signal voltages shall be less than or equal to the values given in the following figure.

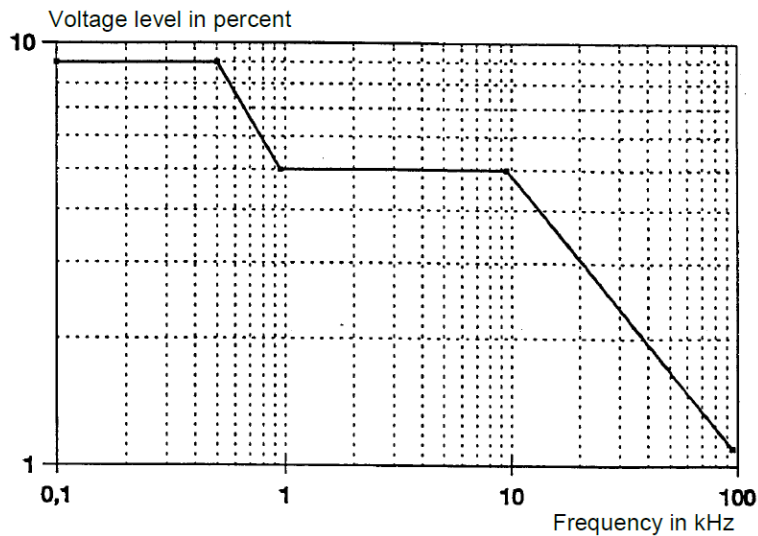

Figure 6.30: Mains signalling voltage level limits according to EN50160

6.2.7 Flicker severity

Under normal operating conditions, in any period of one week the long-term flicker severity caused by voltage fluctuation should be $P_{lt} \leq 1$ for 95 % of the time.

6.2.8 Voltage dips

Voltage dips are typically originated by faults occurring in the public network or in network users' installations. The annual frequency varies greatly depending on the type of supply system and on the point of observation. Moreover, the distribution over the year can be very irregular. The majority of voltage dips have duration less than 1 s and a retained voltage greater than 40 %. Conventionally, the dip start threshold is equal to 90 % of the nominal voltage of the nominal voltage. Collected voltage dips are classified according to the following table.

Table 6.10: Voltage dips classification

Residual voltage	Duration (ms)				
	$10 \leq t \leq 200$	$200 < t \leq 500$	$500 < t \leq 1000$	$1000 < t \leq 5000$	$5000 < t \leq 60000$
$90 > U \geq 80$	Cell A1	Cell A2	Cell A3	Cell A4	Cell A5
$80 > U \geq 70$	Cell B1	Cell B2	Cell B3	Cell B4	Cell B5
$70 > U \geq 40$	Cell C1	Cell C2	Cell C3	Cell C4	Cell C5
$40 > U \geq 5$	Cell D1	Cell D2	Cell D3	Cell D4	Cell D5
$U < 5$	Cell E1	Cell E2	Cell E3	Cell E4	Cell E5

6.2.9 Voltage swells

Voltage swells are typically caused by switching operations and load disconnections. Conventionally, the start threshold for swells is equal to the 110 % of the nominal voltage. Collected voltage swells are classified according to the following table.

Table 6.11: Voltage swell classification

Swell voltage	Duration (ms)		
	$10 \leq t \leq 500$	$500 < t \leq 5000$	$5000 < t \leq 60000$
$U \geq 120$	Cell A1	Cell A2	Cell A3
$120 > U > 110$	Cell B1	Cell B2	Cell B3

6.2.10 Short interruptions of the supply voltage

Under normal operating conditions the annual occurrence of short interruptions of the supply voltage ranges from up to a few tens to up to several hundreds. The duration of approximately 70 % of the short interruptions may be less than one second.

6.2.11 Long interruptions of the supply voltage

Under normal operating conditions the annual frequency of accidental voltage interruptions longer than three minutes may be less than 10 or up to 50 depending on the area.

6.2.12 Recorder setting for EN 50160 survey

Energy Master XA/Energy Master is able to perform EN 50160 surveys on all values described in previous sections. In order to simplify procedure, Energy Master XA/Energy Master has predefined recorder configuration (EN 50160) for it. By default, all current parameters (RMS, THD, etc.) are also included in survey, which can provide additional survey information. Additionally, during voltage quality survey user can simultaneously record other parameters too, such as power, energy and current harmonics.

In order to collect voltage events during recording, **Include events** option in recorder should be enabled. See section 4.21.2 for voltage events settings.



Figure 6.31: Predefined EN50160 recorder configuration

After recording is finished, EN 50160 survey is *performed* on PowerView v3.0 software. See PowerView v3.0 manual for details.

7 Technical specifications

7.1 General specifications

Working temperature range:	-20 °C ÷ +55 °C
Storage temperature range:	-20 °C ÷ +70 °C
Max. humidity:	95 % RH (0 °C ÷ 40 °C), non-condensing
Pollution degree:	2
Protection classification:	Reinforced insulation
Measuring category:	CAT IV / 600 V; CAT III / 1000 V; up to 4000 meters above sea level
Protection degree:	IP 40 Indoor use IP 65 with A 1565 waterproof mounting case Outdoor use
Dimensions:	23 cm x 14cm x 8 cm
Weight (with batteries):	0.96 kg
Display:	Colour 4.3 TFT liquid crystal display (LCD) with backlight, 480 x 272 dots.
Memory:	8 GB microSD card provided; max. 32 GB supported
Batteries:	6 x 1.2 V NiMH rechargeable batteries type HR 6 (AA) Provide full operation for up to 6 hours*
External DC supply – charger:	100-240 V~, 50-60 Hz, 0.4 A~, CAT II 300 V 12 V DC, min 1.2 A
Maximum supply consumption:	12 V / 300 mA – without batteries 12 V / 1 A – while charging batteries
Battery charging time:	3 hours*
Communication:	USB 2.0 Standard USB Type B

* The charging time and the operating hours are given for batteries with a nominal capacity of 2400 mAh.

7.2 Measurements

7.2.1 General description

Max. input voltage (Phase – Neutral):	1000 V _{RMS}
Max. input voltage (Phase – Phase):	1730 V _{RMS}
Phase – Neutral input impedance:	6 MΩ
Phase – Phase input impedance:	6 MΩ
AD converter	16 bit 8 channels, simultaneous sampling
Sampling frequency:	
	7 kSamples/sec Passband (-3dB): 0 ÷ 3.4 kHz

50Hz / 60 Hz System frequency Antialiasing filter	Stopband (-80dB): > 30 kHz
Transient mode Antialiasing filter Note: Energy Master XA only	30.6 kSamples/sec Passband (-3dB): 0 ÷ 8.0 kHz Stopband (-80dB): > 80 kHz
Reference temperature	23 °C ± 2 °C
Temperature influence	75 ppm/°C
Warmup time	Recommended warmup time 30 minutes

NOTE: Instrument has 4 internal voltage ranges. Range is chosen automatically, according to the chosen Nominal Voltage parameter. See tables below for details.

Nominal phase (L-N) voltage: U_{Nom}	Voltage range
50 V ÷ 120 V (L-N)	Range 1
121 V ÷ 240 V (L-N)	Range 2
241 V ÷ 480 V (L-N)	Range 3
481 V ÷ 1000 V (L-N)	Range 4

Nominal phase-to-phase (L-L) voltage: U_{Nom}	Voltage range
50 V ÷ 208 V (L-L)	Range 1
209 V ÷ 416 V (L-L)	Range 2
417 V ÷ 831 V (L-L)	Range 3
832 V ÷ 1730 V (L-L)	Range 4

NOTE: Assure that all voltage clips are connected during measurement and logging period. Unconnected voltage clips are susceptible to EMI and can trigger false events. It is advisable to short them with instrument neutral voltage input.

7.2.2 Phase Voltages

7.2.2.1 10/12 cycle phase RMS voltage: U_{1Rms} , U_{2Rms} , U_{3Rms} , AC+DC

Measuring Range	Resolution*	Accuracy	Nominal Voltage U_{NOM}
10% U_{NOM} ÷ 150% U_{NOM}	10 mV, 100mV	± 0.2 % · U_{NOM}	50 ÷ 1000 V (L-N)

* - depends on measured voltage

7.2.2.2 Half cycle RMS voltage (events, min, max): $U_{1Rms(1/2)}$, $U_{2Rms(1/2)}$, $U_{3Rms(1/2)}$, U_{1Min} , U_{2Min} , U_{3Min} , U_{1Max} , U_{2Max} , U_{3Max} , AC+DC

Measuring Range	Resolution*	Accuracy	Nominal Voltage U_{NOM}
3% U_{NOM} ÷ 150% U_{NOM}	10 mV, 100mV	± 0.4 % · U_{NOM}	50 ÷ 1000 V (L-N)

* - depends on measured voltage

7.2.2.3 NOTE: Voltage events measurements are based on half cycle RMS voltage.

7.2.2.4 Crest factor: CF_{U1} , CF_{U2} , CF_{U3} , CF_{UN}

Measuring range	Resolution*	Accuracy
-----------------	-------------	----------

1.00 ÷ 2.50	0.01	± 5 % · CF _U
-------------	------	-------------------------

* - depends on measured voltage

7.2.2.5 Peak voltage: U_{1Pk} , U_{2Pk} , U_{3Pk} , AC+DC

Measuring range	Resolution*	Accuracy
Range 1: 20.0 ÷ 255.0 Vpk	10 mV, 100 mV	± 1.0 % · U _{pk}
Range 2: 50.0 V ÷ 510.0 Vpk	10 mV, 100 mV	± 1.0 % · U _{pk}
Range 3: 110.0 V ÷ 1000.0 Vpk	100 mV, 1V	± 1.0 % · U _{pk}
Range 4: 200.0 V ÷ 2250.0 Vpk	100 mV, 1V	± 1.0 % · U _{pk}

* - depends on measured voltage

7.2.3 Line voltages

7.2.3.1 10/12 cycle line to line RMS voltage: U_{12Rms} , U_{23Rms} , U_{31Rms} , AC+DC

Measuring Range	Resolution*	Accuracy	Nominal Voltage range
10% U _{NOM} ÷ 150% U _{NOM}	10 mV, 100mV	± 0.2 % · U _{NOM}	50 ÷ 1730 V (L-L)

7.2.3.2 Half cycle RMS voltage (events, min, max): $U_{12Rms(1/2)}$, $U_{23Rms(1/2)}$, $U_{31Rms(1/2)}$, U_{12Min} , U_{23Min} , U_{31Min} , U_{12Max} , U_{23Max} , U_{31Max} , AC+DC

Measuring Range	Resolution*	Accuracy	Nominal Voltage range
10% U _{NOM} ÷ 150% U _{NOM}	10 mV, 100mV	± 0.4 % · U _{NOM}	50 ÷ 1730 V (L-L)

7.2.3.3 Crest factor: CF_{U21} , CF_{U23} , CF_{U31}

Measuring range	Resolution	Accuracy
1.00 ÷ 2.50	0.01	± 5 % · CF _U

7.2.3.4 Peak voltage: U_{12Pk} , U_{23Pk} , U_{31Pk} , AC+DC

Measuring range	Resolution	Accuracy
Range 1: 35.0 ÷ 440.0 Vpk	10 mV, 100 mV	± 1.0 % · U _{pk}
Range 2: 87.0 V ÷ 880.0 Vpk	10 mV, 100 mV	± 1.0 % · U _{pk}
Range 3: 190.0 V ÷ 1730.0 Vpk	100 mV, 1V	± 1.0 % · U _{pk}
Range 4: 345.0 V ÷ 3700.0 Vpk	100 mV, 1V	± 1.0 % · U _{pk}

7.2.4 Current

Input impedance: 100 kΩ

7.2.4.1 10/12 cycle RMS current I_{1Rms} , I_{2Rms} , I_{3Rms} , I_{NRms} , AC+DC.

Clamps	Range	Measuring range	Overall current accuracy
A 1281	1000 A	100 A ÷ 1200 A	±1.2 % · I _{RMS}
	100 A	10 A ÷ 175 A	
	5 A	0.5 A ÷ 10 A	

	0.5 A	50 mA ÷ 1 A	
A 1588	50 A 5 A 0.5 A	5 A ÷ 100 A 0.5 A ÷ 10 A 50 mA ÷ 1 A	±1.0 % · I _{RMS}
A 1398 PQA	10 A	0.5 A ÷ 20 A	±0.8 % · I _{RMS}
A 1069	100 A 10 A	5 A ÷ 200 A 500 mA ÷ 20 A	±1.3 % · I _{RMS}
A 1783	200 A 20 A	5 A ÷ 200 A 500 mA ÷ 20 A	±0.8 % · I _{RMS}
A 1391 PQA	100 A 10 A	5 A ÷ 200 A 500 mA ÷ 20 A	±1.7 % · I _{RMS}
A 1636	1500 A	45 A ÷ 2000 A	±3.5 % · FS
A 1227	3000 A 300 A 30 A	300 A ÷ 6000 A 30 A ÷ 600 A 3 A ÷ 60 A	±2.0 % · I _{RMS}
A 1227 5M	3000 A 300 A 30 A	300 A ÷ 6000 A 30 A ÷ 600 A 3 A ÷ 60 A	±2.0 % · I _{RMS}
A 1445	3000 A 300 A 30 A	300 A ÷ 6000 A 30 A ÷ 600 A 3 A ÷ 60 A	±2.0 % · I _{RMS}
A 1582	3000 A 300 A 30 A	300 A ÷ 6000 A 30 A ÷ 600 A 3 A ÷ 60 A	±2.0 % · I _{RMS}
A 1501	3000 A 300 A 30 A	300 A ÷ 6000 A 30 A ÷ 600 A 3 A ÷ 60 A	±2.0 % · I _{RMS}
A 1502	3000 A 300 A 30 A	300 A ÷ 6000 A 30 A ÷ 600 A 3 A ÷ 60 A	±2.0 % · I _{RMS}
A 1503	6000 A 600 A 60 A	600 A ÷ 12 000 A 60 A ÷ 1200 A 6 A ÷ 120 A	±2.0 % · I _{RMS}
A 1446	6000 A 600 A 60 A	600 A ÷ 12 000 A 60 A ÷ 1200 A 6 A ÷ 120 A	±2.0 % · I _{RMS}
A 1037	6 A 0.5 A	0.5 A ÷ 10 A 10 mA ÷ 10 A	±0.8 % · I _{RMS}

Note: Overall accuracy (as percent of measured value), is provided as guideline. For exact measuring range and accuracy please check user manual of related current clamps. Overall accuracy is calculated as:

$$\text{Overall Accuracy} = 1,15 \cdot \sqrt{\text{Instrument Accuracy}^2 + \text{Clamp Accuracy}^2}$$

7.2.4.2 Half cycle RMS current (min, max) I_{1Rms(1/2)}, I_{2Rms(1/2)}, I_{3Rms(1/2)}, I_{NRms(1/2)}, AC+DC

Clamps	Range	Measuring range	Overall current accuracy
A 1281	1000 A 100 A	100 A ÷ 1200 A	±1.4 % · I _{RMS}

	5 A 0.5 A	10 A ÷ 175 A 0.5 A ÷ 10 A 50 mA ÷ 1 A	
A 1588	50 A 5 A 0.5 A	5 A ÷ 100 A 0.5 A ÷ 10 A 50 mA ÷ 1 A	$\pm 1.2 \% \cdot I_{RMS}$
A 1398 PQA	10 A	0.5 A ÷ 20 A	$\pm 1.0 \% \cdot I_{RMS}$
A 1783	200 A 20 A	5 A ÷ 200 A 500 mA ÷ 20 A	$\pm 0.8 \% \cdot I_{RMS}$
A 1391 PQA	100 A 10 A	5 A ÷ 200 A 500 mA ÷ 20 A	$\pm 1.9 \% \cdot I_{RMS}$
A 1636	1500 A	45 A ÷ 1500 A	$\pm 3.8 \% \cdot FS$
A 1227	3000 A 300 A 30 A	300 A ÷ 6000 A 30 A ÷ 600 A 3 A ÷ 60 A	$\pm 2.2 \% \cdot I_{RMS}$
A 1445	3000 A 300 A 30 A	300 A ÷ 6000 A 30 A ÷ 600 A 3 A ÷ 60 A	$\pm 2.2 \% \cdot I_{RMS}$
A 1582	3000 A 300 A 30 A	300 A ÷ 6000 A 30 A ÷ 600 A 3 A ÷ 60 A	$\pm 2.2 \% \cdot I_{RMS}$
A 1501	3000 A 300 A 30 A	300 A ÷ 6000 A 30 A ÷ 600 A 3 A ÷ 60 A	$\pm 2.2 \% \cdot I_{RMS}$
A 1502	3000 A 300 A 30 A	300 A ÷ 6000 A 30 A ÷ 600 A 3 A ÷ 60 A	$\pm 2.2 \% \cdot I_{RMS}$
A 1503	6000 A 600 A 60 A	600 A ÷ 12 000 A 60 A ÷ 1200 A 6 A ÷ 120 A	$\pm 2.2 \% \cdot I_{RMS}$
A 1446	6000 A 600 A 60 A	600 A ÷ 12 000 A 60 A ÷ 1200 A 6 A ÷ 120 A	$\pm 2.2 \% \cdot I_{RMS}$
A 1037	6 A 0.5 A	0.5 A ÷ 10 A 10 mA ÷ 10 A	$\pm 1.0 \% \cdot I_{RMS}$

Note: Overall accuracy (as percent of measured value), is provided as guideline. For exact measuring range and accuracy please check user manual of related current clamps. Overall accuracy is calculated as:

$$Overall\ Accuracy = 1,15 \cdot \sqrt{Instrument\ Accuracy^2 + Clamp\ Accuracy^2}$$

7.2.4.3 Peak value I_{1Pk} , I_{2Pk} , I_{3Pk} , I_{Npk} , AC+DC

Measurement accessory		Peak value	Overall current accuracy
A 1588	50 A 5 A 0.5 A	5 A ÷ 100 A 0.5 A ÷ 10 A 50 mA ÷ 1 A	$\pm 1.4 \% \cdot I_{RMS}$
A 1398 PQA	10 A	0.5 A ÷ 20 A	$\pm 1.0 \% \cdot I_{RMS}$

A 1783	200 A 20 A	5 A ÷ 200 A 500 mA ÷ 20 A	±0.8 % · I _{RMS}
A 1391 PQA	100 A 10 A	5 A ÷ 200 A 500 mA ÷ 20 A	±1.9 % · I _{RMS}
A 1636	1500 A	45 A ÷ 1500 A	±4.0 % · FS
A 1227	3000 A 300 A 30 A	300 A ÷ 6000 A 30 A ÷ 600 A 3 A ÷ 60 A	±2.4 % · I _{RMS}
A 1445	3000 A 300 A 30 A	300 A ÷ 6000 A 30 A ÷ 600 A 3 A ÷ 60 A	±2.2 % · I _{RMS}
A 1582	3000 A 300 A 30 A	300 A ÷ 6000 A 30 A ÷ 600 A 3 A ÷ 60 A	±2.2 % · I _{RMS}
A 1501	3000 A 300 A 30 A	300 A ÷ 6000 A 30 A ÷ 600 A 3 A ÷ 60 A	±2.2 % · I _{RMS}
A 1502	3000 A 300 A 30 A	300 A ÷ 6000 A 30 A ÷ 600 A 3 A ÷ 60 A	±2.2 % · I _{RMS}
A 1503	6000 A 600 A 60 A	600 A ÷ 12 000 A 60 A ÷ 1200 A 6 A ÷ 120 A	±2.2 % · I _{RMS}
A 1446	6000 A 600 A 60 A	600 A ÷ 12 000 A 60 A ÷ 1200 A 6 A ÷ 120 A	±2.2 % · I _{RMS}
A 1037	6 A 0.5 A	0.5 A ÷ 10 A 10 mA ÷ 10 A	±1.0 % · I _{RMS}

Note: Overall accuracy (as percent of measured value), is provided as guideline. For exact measuring range and accuracy please check user manual of related current clamps. Overall accuracy is calculated as:

$$\text{Overall Accuracy} = 1,15 \cdot \sqrt{\text{Instrument Accuracy}^2 + \text{Clamp Accuracy}^2}$$

7.2.4.4 Crest factor CF_{ip} p: [1, 2, 3, 4, N], AC+DC

Measuring range	Resolution	Accuracy
1.00 ÷ 10.00	0.01	± 5 % · CF _I

7.2.4.5 Accuracy of 10/12 cycle RMS voltage measured on current input

Measuring range (Intrinsic instrument accuracy)	Accuracy
Range 1: 10.0 mV _{RMS} ÷ 300.0 mV _{RMS}	±0.5 % · U _{RMS}
Range 2: 50.0 mV _{RMS} ÷ 3.000 V _{RMS}	

Measuring range	Accuracy	Crest factor
Range 1: 10.0 mVRMS ÷ 150.0 mVRMS	± 0.5 % · U _{RMS}	3.0
Range 2: 50.0 mVRMS ÷ 1.500 VRMS		

U_{RMS} – RMS voltage measured on current input

7.2.4.6 Accuracy of half cycle RMS voltage measured on current input

Measuring range (Intrinsic instrument accuracy)	Accuracy
Range 1: 10.0 mV _{RMS} ÷ 300.0 mV _{RMS}	± 1.0 % · U_{RMS}
Range 2: 50.0 mV _{RMS} ÷ 3.0000 V _{RMS}	± 1.0 % · U_{RMS}

Measuring range	Accuracy	Crest factor
Range 1: 10.0 mVRMS ÷ 150.0 mVRMS	± 1.0 % · U_{RMS}	3.0
Range 2: 50.0 mVRMS ÷ 1.500 VRMS		

7.2.5 Frequency

Measuring range	Resolution	Accuracy
50 Hz system frequency: 42.500 Hz ÷ 57.500 Hz 60 Hz system frequency: 51.000 Hz ÷ 69.000 Hz	1 mHz	± 10 mHz

7.2.6 Flickers

Flicker type	Measuring range	Resolution	Accuracy*
P_{inst}	0.200 ÷ 10.000	0.001	± 5 % · P_{inst}
P_{st}	0.200 ÷ 10.000		± 5 % · P_{st}
P_{lt}	0.200 ÷ 10.000		± 5 % · P_{lt}

7.2.7 Combined power

Combined Power	Measuring range		Accuracy
Active power* (W) P_1, P_2, P_3, P_{tot}	0.000 k ÷ 999.9 M 4 digits	Excluding clamps (Instrument only)	±0.5 % · P
		With flex clamps A 1227 / 3000 A A 1446 / 6000 A	±2.0 % · P
		With iron clamps A 1281 / 1000 A	±1.0 % · P
Nonactive power** (var) N_1, N_2, N_3, N_{tot}	0.000 k ÷ 999.9 M 4 digits	Excluding clamps (Instrument only)	±0.8 % · Q
		With flex clamps A 1227 / 3000 A A 1446 / 6000 A	±2.0 % · Q
		With iron clamps A 1281 / 1000 A	±1.0 % · Q
Apparent power*** (VA)	0.000 k ÷ 999.9 M	Excluding clamps (Instrument only)	±0.8 % · S

S ₁ , S ₂ , S ₃ , S _{tot}	4 digits	With flex clamps A 1227 / 3000 A A 1446 / 6000 A	±2.0 % · S
		With iron clamps A 1281 / 1000 A	±1.0 % · S

*Accuracy values are valid if $\cos \varphi \geq 0.80$, $I \geq 10 \% I_{Nom}$ and $U \geq 80 \% U_{Nom}$

**Accuracy values are valid if $\sin \varphi \geq 0.50$, $I \geq 10 \% I_{Nom}$ and $U \geq 80 \% U_{Nom}$

***Accuracy values are valid if $\cos \varphi \geq 0.50$, $I \geq 10 \% I_{Nom}$ and $U \geq 80 \% U_{Nom}$

7.2.8 Fundamental power

Fundamental power	Measuring range		Accuracy
Active fundamental power* (W) Pfund ₁ , Pfund ₂ , Pfund ₃ , P ⁺ _{tot}	0.000 k ÷ 999.9 M 4 digits	Excluding clamps (Instrument only)	±0.5 % · P _{fund}
		With flex clamps A 1227 / 3000 A A 1446 / 6000 A	±2.0 % · P _{fund}
		With iron clamps A 1281 / 1000 A	±1.0 % · P _{fund}
Reactive fundamental power** (var) Qfund ₁ , Qfund ₂ , Qfund ₃ , Q ⁺ _{tot}	0.000 k ÷ 999.9 M 4 digits	Excluding clamps (Instrument only)	±0.5 % · Q _{fund}
		With flex clamps A 1227 / 3000 A A 1446 / 6000 A	±2.0 % · Q _{fund}
		With iron clamps A 1281 / 1000 A	±1.0 % · Q _{fund}
Apparent fundamental power*** (VA) Sfund ₁ , Sfund ₂ , Sfund ₃ , S ⁺ _{tot}	0.000 k ÷ 999.9 M 4 digits	Excluding clamps (Instrument only)	±0.5 % · S _{fund}
		With flex clamps A 1227 / 3000 A A 1446 / 6000 A	±2.0 % · S _{fund}
		With iron clamps A 1281 / 1000 A	±1.0 % · S _{fund}

*Accuracy values are valid if $\cos \varphi \geq 0.80$, $I \geq 10 \% I_{Nom}$ and $U \geq 80 \% U_{Nom}$

**Accuracy values are valid if $\sin \varphi \geq 0.50$, $I \geq 10 \% I_{Nom}$ and $U \geq 80 \% U_{Nom}$

***Accuracy values are valid if $\cos \varphi \geq 0.50$, $I \geq 10 \% I_{Nom}$ and $U \geq 80 \% U_{Nom}$

7.2.9 Nonfundamental power

Nonfundamental power	Measuring range	Conditions	Accuracy
----------------------	-----------------	------------	----------

Active harmonic power* (W) $Ph_1, Ph_2, Ph_3, Ph_{tot}$	0.000 k ÷ 999.9 M 4 digits	Excluding clamps (Instrument only) $Ph > 1\% \cdot P$	$\pm 1.0\% \cdot Ph$
Current distortion power* (var) $D_{I1}, D_{I2}, D_{I3}, D_{eI}$,	0.000 k ÷ 999.9 M 4 digits	Excluding clamps (Instrument only) $D_I > 1\% \cdot S$	$\pm 2.0\% \cdot D_I$
Voltage distortion power* (var) $D_{V1}, D_{V2}, D_{V3}, D_{eV}$	0.000 k ÷ 999.9 M 4 digits	Excluding clamps (Instrument only) $D_V > 1\% \cdot S$	$\pm 2.0\% \cdot D_V$
Harmonics distortion power* (var) $D_{H1}, D_{H2}, D_{H3}, D_{eH}$	0.000 k ÷ 999.9 M 4 digits	Excluding clamps (Instrument only) $D_H > 1\% \cdot S$	$\pm 2.0\% \cdot D_H$
Apparent nonfundamental power* (VA) $S_{N1}, S_{N2}, S_{N3}, S_{eN}$	0.000 k ÷ 999.9 M 4 digits	Excluding clamps (Instrument only) $S_N > 1\% \cdot S$	$\pm 1.0\% \cdot S_N$
Apparent harmonic power* (VA) $S_{H1}, S_{H2}, S_{H3}, S_{eH}$	0.000 k ÷ 999.9 M 4 digits	Excluding clamps (Instrument only) $S_H > 1\% \cdot S$	$\pm 2.0\% \cdot S_H$

*Accuracy values are valid if $I \geq 10\% I_{Nom}$ and $U \geq 80\% U_{Nom}$

7.2.10 Power factor (PF)

Measuring range	Resolution	Accuracy
-1.00 ÷ 1.00	0.01	± 0.02

7.2.11 Displacement factor (DPF) or Cos φ

Measuring range	Resolution	Accuracy
-1.00 ÷ 1.00	0.01	± 0.02

7.2.12 Energy

		Measuring range (kWh, kvarh, kVAh)	Resolution	Accuracy
Active energy Ep*	Excluding clamps (Instrument only)	000,000,000.001 ÷ 999,999,999.999	12 digits	±0.5 % · Ep
	With A 1227, A 1446 Flex clamps	000,000,000.001 ÷ 999,999,999.999		±2.0 % · Ep
	With A 1281 Multirange clamps 1000 A	000,000,000.001 ÷ 999,999,999.999		±1.0 % · Ep
Reactive energy Eq**	Excluding clamps (Instrument only)	000,000,000.001 ÷ 999,999,999.999	12 digits	±0.5 % · Eq
	With A 1227, A 1446 Flex clamps	000,000,000.001 ÷ 999,999,999.999		±2.0 % · Eq
	With A 1281 Multirange clamps 1000 A	000,000,000.001 ÷ 999,999,999.999		±1.0 % · Eq

*Accuracy values are valid if $\cos \varphi \geq 0.80$, $I \geq 10 \% I_{Nom}$ and $U \geq 80 \% U_{Nom}$

**Accuracy values are valid if $\sin \varphi \geq 0.50$, $I \geq 10 \% I_{Nom}$ and $U \geq 80 \% U_{Nom}$

7.2.13 Voltage harmonics and THD

Measuring range	Resolution	Accuracy
$U_{hN} < 3 \% U_{Nom}$	10 mV	± 0.15 % · U_{Nom}
$3 \% U_{Nom} < U_{hN} < 20 \% U_{Nom}$	10 mV	± 5 % · U_{hN}

U_{Nom} : Nominal voltage (RMS)

U_{hN} : measured harmonic voltage

N: harmonic component 0th ÷ 50th

Measuring range	Resolution	Accuracy
$0 \% U_{Nom} < THD_U < 20 \% U_{Nom}$	0.1 %	± 0.4

U_{Nom} : nominal voltage (RMS)

7.2.14 Current harmonics, THD and k-factor

Measuring range	Resolution	Accuracy
$I_{hN} < 10 \% I_{Nom}$	10 mV	± 0.15 % · I_{Nom}
$10 \% I_{Nom} < I_{hN} < 100 \% I_{Nom}$	10 mV	± 5 % · I_{hN}

I_{Nom} : Nominal clamp current (RMS)

I_{hN} : measured harmonic current

N: harmonic component 0th ÷ 50th

Measuring range	Resolution	Accuracy
$0 \% I_{Nom} < THD_I < 100 \% I_{Nom}$	0.1 %	± 0.6

$100 \% I_{Nom} < THD_I < 200 \% I_{Nom}$	0.1 %	± 0.3
---	-------	-----------

I_{Nom} : Nominal current (RMS)

Measuring range	Resolution	Accuracy
$0 < k < 200$	0.1	± 0.6

7.2.15 Voltage interharmonics

Measuring range	Resolution	Accuracy
$U_{ihN} < 3 \% U_{Nom}$	10 mV	$\pm 0.15 \% \cdot U_{Nom}$
$3 \% U_{Nom} < U_{ihN} < 20 \% U_{Nom}$	10 mV	$\pm 5 \% \cdot U_{ihN}$

U_{Nom} : nominal voltage (RMS)

U_{ihN} : measured harmonic voltage

N : interharmonic component $0^{th} \div 50^{th}$

7.2.16 Current interharmonics

Measuring range	Resolution	Accuracy
$I_{hN} < 10 \% I_{Nom}$	10 mV	$\pm 0.15 \% \cdot I_{Nom}$
$10 \% I_{Nom} < I_{hN} < 100 \%$	10 mV	$\pm 5 \% \cdot I_{hN}$

I_{Nom} : Nominal current (RMS)

I_{hN} : measured interharmonic current

N : interharmonic component $0^{th} \div 50^{th}$

7.2.17 Signalling

Measuring range	Resolution	Accuracy
$1 \% U_{Nom} < U_{Sig} < 3 \% U_{Nom}$	10 mV	$\pm 0.15 \% \cdot U_{Nom}$
$3 \% U_{Nom} < U_{Sig} < 20 \% U_{Nom}$	10 mV	$\pm 5 \% \cdot U_{Sig}$

U_{Nom} : Nominal current (RMS)

U_{Sig} : Measured signalling voltage

7.2.18 Unbalance

	Unbalance range	Resolution	Accuracy
u^-	0.5 % \div 5.0 %	0.1 %	$\pm 0.3 \%$
u^0			$\pm 0.3 \%$
i^-	0.0 % \div 20 %	0.1 %	$\pm 1 \%$
i^0			$\pm 1 \%$

7.2.19 Overdeviation and Underdeviation

	Measuring range	Resolution	Accuracy
U_{Over}	$0 \div 50 \% U_{Nom}$	0.001 %	$\pm 0.15 \%$
U_{Under}	$0 \div 90 \% U_{Nom}$	0.001 %	$\pm 0.15 \%$

7.2.20 Time and duration uncertainty

Standard compliance: IEC 61000-4-30 Class S (Section 4.6)

7.2.20.1 Real time clock (RTC) temperature uncertainty

Operating range	Accuracy	
-20 °C ÷ 70 °C	± 3.5 ppm	0.3 s/day
0 °C ÷ 40 °C	± 2.0 ppm	0.17 s/day

7.2.20.2 Event duration and recorder time-stamp and uncertainty

	Measuring Range	Resolution	Error
Event Duration	10 ms ÷ 7 days	1 ms	± 1 cycle
Record and Event Time stamp	N/A	1 ms	± 1 cycle

7.2.21 Temperature probe

Measuring range	Resolution	Accuracy
-10.0 °C ÷ 85.0 °C	0.1 °C	± 0.5°C
-20.0 °C ÷ -10.0 °C and 85.0 °C ÷ 125.0 °C		± 2.0°C

7.2.22 Phase angle

Measuring range	Resolution	Accuracy
-180.0° ÷ 180.0°	0.1°	± 0.6°

7.3 Recorders**7.3.1 General recorder**

Sampling	According to the IEC 61000-4-30 Class S requirements. The basic measurement time interval for voltage, harmonics, interharmonics and unbalance is 10-cycle time interval for a 50 Hz power system and 12-cycle time interval for a 60 Hz power system. Instrument provides approximately 3 readings per second, continuous sampling. All channels are sampled simultaneously. For harmonics measurement input samples are resampled, in order to assure that sampling frequency is continuously synchronized with main frequency.
Recording quantities	Voltage, current, frequency, crest factors, power, energy, 50 harmonics, 50 interharmonics, flickers, signalling, unbalance, under and over deviation. See section 5.4 for details which minimum, maximum, average and active average values are stored for each parameter.
Recording interval	1 s, 3 s (150 / 180 cycles), 5 s, 10 s, 1 min, 2 min, 5 min, 10 min, 15 min, 30 min, 60 min, 120 min.
Events	All events, without limitation can be stored into record.
Alarms	All alarms, without limitation can be stored into record.
Trigger	Predefined start time or manual start.

Note: If during record session instrument batteries are drained, due to long interruption for example, instrument will shut down and after electricity comes back, it will automatically restart recording session.

Table 7.1: General recording max. duration

Recording interval	Max. record duration*
1 s	12 hours
3 s (150 / 180 cycles)	2 days
5 s	3 days
10 s	7 days
1 min	30 days
2 min	60 days
5 min	
10 min	
15 min	
30 min	> 60 days
60 min	
120 min	

*At least 2 GB of free space should be available on microSD card.

In case, that record duration is set to “Manual”, that instrument automatically start new recorder after the first one is finished due to reach the maximum file length. Instrument perform so many recorders, as it is available memory on the SD card.

In this manner a single microSD card with a capacity of 7.566 GB (nominal 8 GB) can save 4 entire recording sessions (each 12 hours long) and an additional 6 hours (all together 4x12 hours + 6 hours, i.e. 2 days and 6 hours of recordings). This approach also works for other time intervals (not just 1 second), maximizing usage of storage capacity on the selected microSD card.



Figure 7.1: General Recorder setup to allow auto-recording restart, when reaches maximum file length

Note: In case of recording with the interval shorter than 5 seconds, we recommend not to record additional network events simultaneously with the recorder due to saving large files to SD card and lot of processes needs to be done.

Note: Recorder file size is limited to 2 GB due to the FAT32 SD card formatting.

7.3.2 Waveform snapshot

Sampling	7 kSamples/s, continuous sampling per channel. All channels are sampled simultaneously.
Recording time	10/12 cycle period.
Recording quantities	Waveform samples of: $U_1, U_2, U_3, (U_{12}, U_{23}, U_{31}), I_1, I_2, I_3, I_N,$ all measurements.
Trigger	Manual

7.4 Standards compliance

7.4.1 Compliance to the IEC 61557-12

7.4.1.1 General and essential characteristics

Power quality assessment function	-A
Classification according to 4.3	SD Indirect current and direct voltage measurement
	SS Indirect current and indirect voltage measurement
Temperature	K50
Humidity + altitude	Standard

7.4.1.2 Measurement characteristics

Function symbols	Class according to IEC 61557-12	Measuring range
P	2	2 % ÷ 200% $I_{Nom}^{(1)}$
Q	2	2 % ÷ 200% $I_{Nom}^{(1)}$
S	2	2 % ÷ 200% $I_{Nom}^{(1)}$
Ep	2	2 % ÷ 200% $I_{Nom}^{(1)}$
Eq	3	2 % ÷ 200% $I_{Nom}^{(1)}$
eS	2	2 % ÷ 200% $I_{Nom}^{(1)}$
PF	0.5	- 1 ÷ 1
I, I_{Nom}	0.5	2 % I_{Nom} ÷ 200 % I_{Nom}
I_{hn}	1	0 % ÷ 100 % I_{Nom}
THD _i	2	0 % ÷ 100 % I_{Nom}

(1) – Nominal current depends on current sensor.

7.4.2 Compliance to the to the IEC 61000-4-30

IEC 61000-4-30 Section and Parameter	Energy Master XA/Energy Master Measurement	Class
4.4 Aggregation of measurements in time intervals* <ul style="list-style-type: none"> • aggregated over 150/180-cycle • aggregated over 10 min • aggregated over 2 h 	Timestamp, Duration	A
4.6 Real time clock (RTC) uncertainty		S
4.7 Flagging		A
5.1 Frequency	Freq	A
5.2 Magnitude of the Supply	U	S
5.3 Flicker	P _{st} , P _{It}	A
5.4 Dips and Swells	U _{Dip} , U _{Swell} , duration	S
5.5 Interruptions	duration	S
5.7 Unbalance	u ⁻ , u ⁰	S
5.8 Voltage Harmonics	U _{h0÷50}	S
5.9 Voltage Interharmonics	U _{ih0÷50}	S
5.10 Mains signalling voltage	U _{Sig}	S
5.12 Underdeviation and overdeviation	U _{Under} , U _{Over}	A

* Instrument aggregate measurement according to selected **Interval:** parameter in GENERAL RECORDER. Aggregated measurements are shown in TREND screens, only if GENERAL RECORDER is active.

8 Maintenance

8.1 Inserting batteries into the instrument

1. Make sure that the power supply adapter/charger and measurement leads are disconnected and the instrument is switched off before opening battery compartment cover (see Figure 3.4).
2. Insert batteries as shown in figure below (insert batteries correctly, otherwise the instrument will not operate and the batteries could be discharged or damaged).



Figure 8.1: Battery compartment

1	Battery cells
2	Serial number label

3. Turn the instrument upside down (see figure below) and put the cover on the batteries.



Figure 8.2: Closing the battery compartment cover

4. Screw the cover on the instrument.

Warnings!

- **Hazardous voltages exist inside the instrument. Disconnect all test leads, remove the power supply cable and turn off the instrument before removing battery compartment cover.**
- **Use only power supply adapter/charger delivered from manufacturer or distributor of the equipment to avoid possible fire or electric shock.**
- **Do not use standard batteries while power supply adapter/charger is connected, otherwise they may explode!**
- **Do not mix batteries of different types, brands, ages, or charge levels.**
- **When charging batteries for the first time, make sure to charge batteries for at least 24 hours before switching on the instrument.**

Notes:

- Rechargeable NiMH batteries, type HR 6 (size AA), are recommended. The charging time and the operating hours are given for batteries with a nominal capacity of 2400 mAh.
- If the instrument is not going to be used for a long period of time remove all batteries from the battery compartment. The enclosed batteries can supply the instrument for approx. 8 to 12 hours (depends on the battery state, environmental conditions etc).

8.2 Batteries

Instrument contains rechargeable NiMH batteries. These batteries should only be replaced with the same type as defined on the battery placement label or in this manual.

If it is necessary to replace batteries, all six have to be replaced. Ensure that the batteries are inserted with the correct polarity; incorrect polarity can damage the batteries and/or the instrument.

8.2.1.1 Precautions on charging new batteries or batteries unused for a longer period

Unpredictable chemical processes can occur during charging new batteries or batteries that were unused for a longer period of time (more than 3 months). NiMH and NiCd batteries are affected

to a various degree (sometimes called as memory effect). As a result, the instrument operation time can be significantly reduced at the initial charging/discharging cycles.

Therefore, it is recommended:

- To completely charge the batteries
- To completely discharge the batteries (can be performed with normal working with the instrument).
- Repeating the charge/discharge cycle for at least two times (four cycles are recommended).

When using external intelligent battery chargers one complete discharging /charging cycle is performed automatically.

After performing this procedure, a normal battery capacity is restored. The operation time of the instrument now meets the data in the technical specifications.

8.2.1.2 Notes

The charger in the instrument is a pack cell charger. This means that the batteries are connected in series during the charging so all batteries have to be in similar state (similarly charged, same type and age).

Even one deteriorated battery (or just of another type) can cause an improper charging of the entire battery pack (heating of the battery pack, significantly decreased operation time).

If no improvement is achieved after performing several charging/discharging cycles the state of individual batteries should be determined (by comparing battery voltages, checking them in a cell charger etc). It is very likely that only some of the batteries are deteriorated.

The effects described above should not be mixed with normal battery capacity decrease over time. All charging batteries lose some of their capacity when repeatedly charged/discharged. The actual decrease of capacity versus number of charging cycles depends on battery type and is provided in the technical specification of batteries provided by battery manufacturer.

8.3 Firmware upgrade

Metrel as manufacturer is constantly adding new features and enhance existing. In order to get most of your instrument, we recommend periodic check for software and firmware updates. In this section firmware upgrade process is described.

8.3.1 Requirements

Firmware upgrade process has following requirements:

- **PC computer** with installed latest version of PowerView software. If your PowerView is out of date, please update it, by clicking on "Check for PowerView updates" in Help menu, and follow the instructions
- **USB cable**

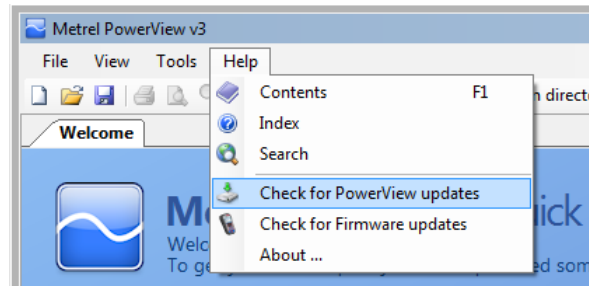

Figure 8.3: PowerView update function

8.3.2 Upgrade procedure

1. Connect PC and instrument with USB cable
2. Establish USB communication between them. In PowerView, go to Tools→Options menu and set USB connection as shown on figure below.

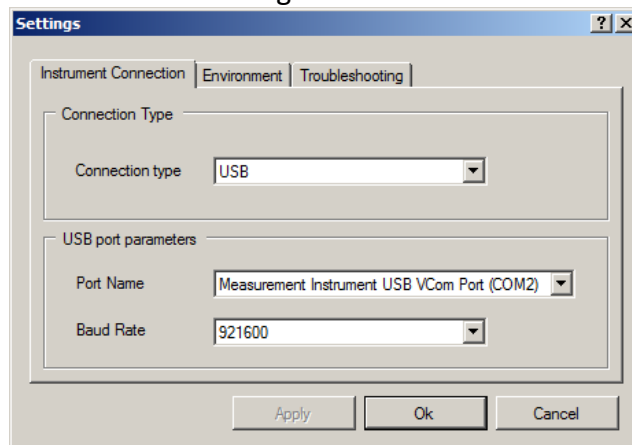

Figure 8.4: Selecting USB communication

3. Click on Help → Check for Firmware updates.

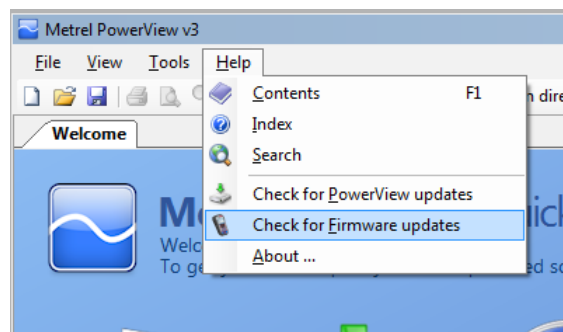

Figure 8.5: Check for Firmware menu

4. Version checker window will appear on the screen. Click on Start button.

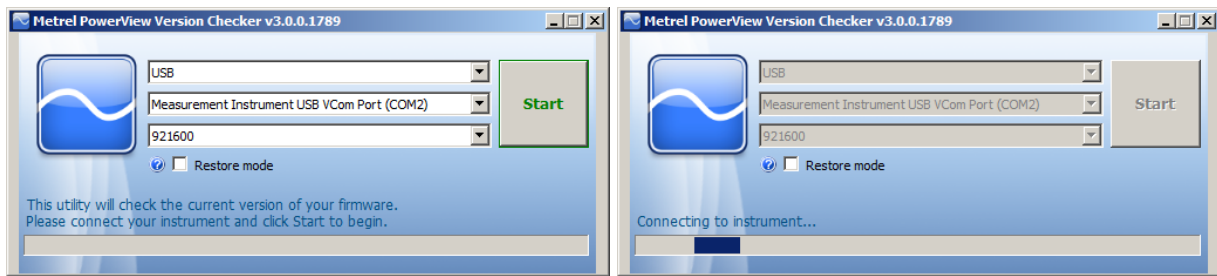

Figure 8.6: Check for Firmware menu

5. If your instrument have older FW, PowerView will notify you that new version of FW is available. Click on Yes to proceed.

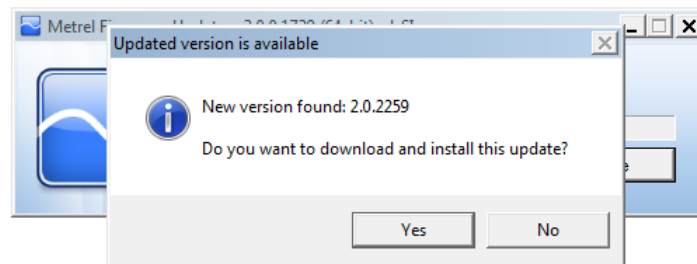

Figure 8.7: New firmware is available for download

6. After update is downloaded, FlashMe application will be launched. This application will actually upgrade instrument FW. Click on RUN to proceed.

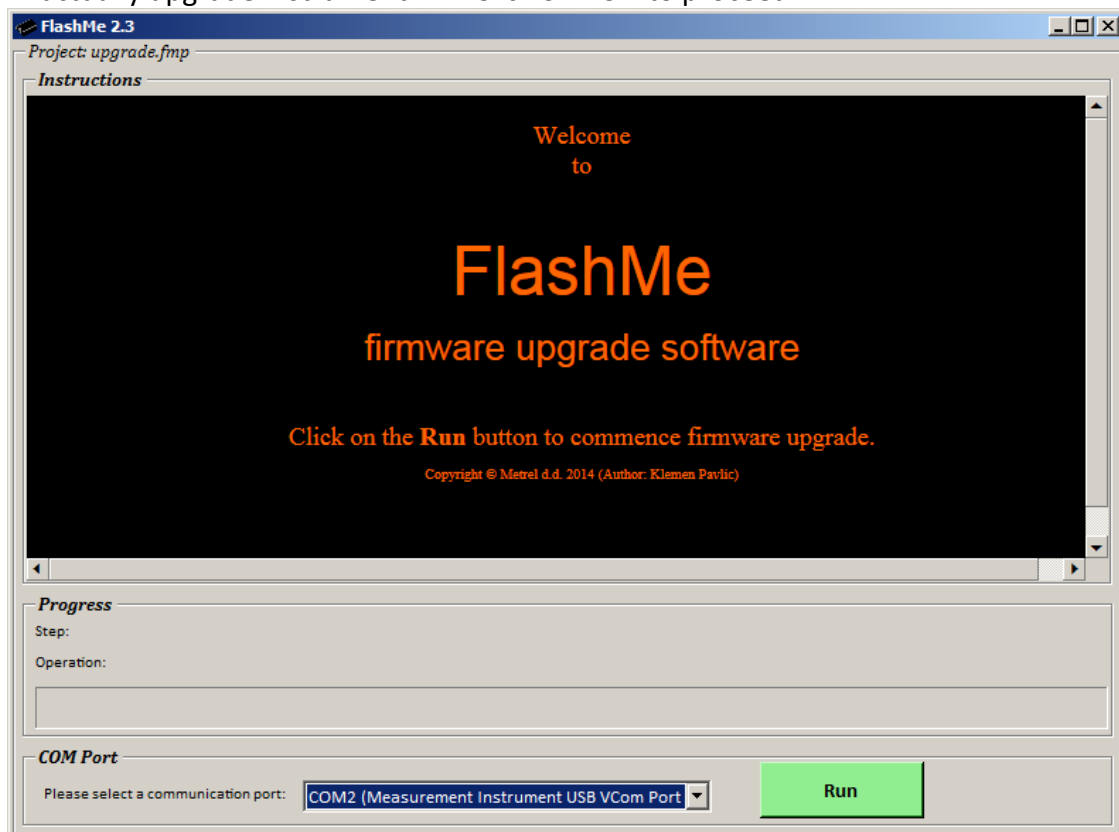

Figure 8.8: FlashMe firmware upgrade software

- FlashMe will automatically detect Power Master instrument, which can be seen in COM port selection menu. In some rare cases user should point FlashMe manually to COM port where instrument is connected. Click then on Continue to proceed.



Figure 8.9: FlashMe configuration screen

- Instrument upgrade process should begin. Please wait until all steps are finished. Note that this step should not be interrupted; as instrument will not work properly. If upgrade process goes wrong, please contact your distributor or Metrel directly. We will help you to resolve issue and recover instrument.



Figure 8.10: FlashMe programming screen

8.4 Power supply considerations

⚠ Warnings

- Use only charger supplied by manufacturer.
- Disconnect power supply adapter if you use standard (non-rechargeable) batteries.

When using the original power supply adapter/charger the instrument is fully operational immediately after switching it on. The batteries are charged at the same time, nominal charging time is 3.5 hours.

The batteries are charged whenever the power supply adapter/charger is connected to the instrument. Inbuilt protection circuit controls the charging procedure and assure maximal battery lifetime. Batteries will be charged only if their temperature is less than 40 °C.

If the instrument is left without batteries and charger for more than 2 minutes, time and date settings are reset.

8.5 Cleaning

To clean the surface of the instrument, use a soft cloth slightly moistened with soapy water or alcohol. Then leave the instrument to dry totally before use.

⚠ Warnings

- Do not use liquids based on petrol or hydrocarbons!
- Do not spill cleaning liquid over the instrument!

8.6 Periodic calibration

To ensure correct measurement, it is essential that the instrument is regularly calibrated. If used continuously on a daily basis, a six-month calibration period is recommended, otherwise annual calibration is sufficient.

8.7 Service

For repairs under or out of warranty please contact your distributor for further information.

8.8 Troubleshooting

If *ESC* button is pressed while switching on the instrument, the instrument will not start. Batteries have to be removed and inserted back. After that the instrument will start normally.

9 Version of document

#	Document version	Description of changes
7	1.7.1	- Connection screen upgrade with PREV & NEXT cursors - Obsolete current clamps removed from the list
6	1.6.1	- Removed obsolete current clamps from the list of available current clamps
5	1.5.1	- Note added – Energy/Demand measurement during current clamp auto ranging - Phase current clamp inversion - A 1783 current clamps added
4	1.4.1	- Update of Standard's definitions - Indoor/Outdoor use - Removed printer section 5.2.6
3	1.3.1	- Added info about recorder auto-restart – when recorder file reaches maximum file length - Added A 1398 PQA current clamps - Added note, related to recording with integration period less than 10 seconds - Removed Record organisation option (Measuring Methods)
2	1.2.1	- Added Backlight functionality - Energy Recorder improvement
1	1.1.1	- First official version

Manufacturer address:

METREL d.o.o.
Ljubljanska 77,
SI-1354 Horjul,
Slovenia

Tel: +(386) 1 75 58 200
Fax: +(386) 1 75 49 095
Email: metrel@metrel.si
<http://www.metrel.si>